

## Power Supply and Voltage Control

AC Power Regulators

# APR-D Series (3-phase)





AC power regulators

# APR-D series (3-phase)



100A  
communication board, supplied



45 / 60A  
standard



20A  
standard

# RPDW

- Adopting the thyristor normal/reverse parallel method (6 arms).
- The output range is 0 to 100% of the main-circuit line voltage. Where the voltage drop portion due to thyristor-specific resistance is excluded.
- You can also switch the waveform control method among phase control, cycle control, and phase angle proportion control.

## Phase control method (0 to 100%)

Output voltage  
Ignition phase angle  $\alpha$

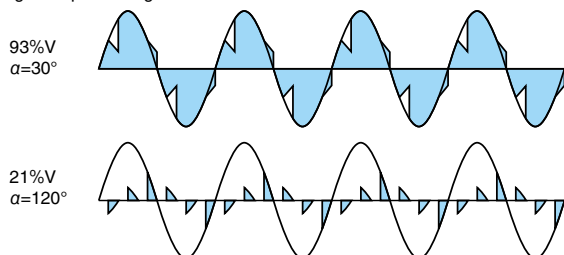

## Cycle control method (Continuous)

Output voltage

71%V  
(1/2)

45%V  
(1/5)

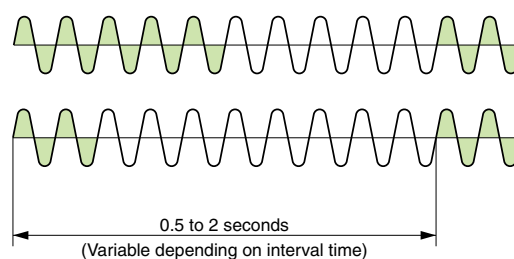

- Output regarding individual settings represents linear characteristics of RMS values.

### **Catalog Disclaimer**

The information contained in this catalog does not constitute an express or implied warranty of quality, any warranty of merchantability of fitness for a particular purpose is hereby disclaimed.

Since the user's product information, specific use application, and conditions of use are all outside of Fuji Electric FA Components & Systems' control, **it shall be the responsibility of the user to determine the suitability of any of the products mentioned for the user's application.**

### **One Year Limited Warranty**

The products identified in this catalog shall be sold pursuant to the terms and conditions identified in the "Conditions of Sale" issued by Fuji Electric FA with each order confirmation.

Except to the extent otherwise provided for in the Conditions of Sale issued by Fuji Electric FA, Fuji Electric FA warrants that the Fuji Electric FA products identified in this catalog shall be free from significant defects in materials and workmanship provided the product has not been: 1) repaired or altered by others than Fuji Electric FA; 2) subjected to negligence, accident, misuse, or damage by circumstances beyond Fuji Electric FA's control; 3) improperly operated, maintained or stored; or 4) used in other than normal use or service. This warranty shall apply only to defects appearing within one (1) year from the date of shipment by Fuji Electric FA, and in such case, only if such defects are reported to Fuji Electric FA within thirty (30) days of discovery by purchaser. Such notice should be submitted in writing to Fuji Electric FA at 5-7, Nihonbashi Odemma-cho, Chuo-ku, Tokyo, Japan. The sole and exclusive remedy with respect to the above warranty whether such claim is based on warranty, contract, negligence, strict liability or any other theory, is limited to the repair or replacement of such product or, at Fuji Electric FA's option reimbursement by Fuji Electric FA of the purchase price paid to Fuji Electric FA for the particular product. **Fuji Electric FA does not make any other representations or warranties, whether oral or in writing, expressed or implied, including but not limited to any warranty regarding merchantability or fitness for a particular purpose.** Except as provided in the Conditions of Sale, no agent or representative of Fuji Electric FA is authorized to modify the terms of this warranty in writing or orally.

In no event shall Fuji Electric FA be liable for special, indirect or consequential damages, including but not limited to, loss of use of the product, other equipment, plant and power system which is installed with the product, loss of profits or revenues, cost of capital, or claims against the purchaser or user of the product by its customers resulting from the use of information, recommendations and descriptions contained herein. The purchaser agrees to pass on to its customers and users, in writing at the time inquiries and orders are received by buyer, Fuji Electric FA's warranty as set forth above.

# AC Power Regulators APR-D Series (3-phase)

---

	Page
Features .....	2
Type number nomenclature .....	3
Types and ratings .....	3
Specifications .....	4
Wiring diagram .....	5
Other options .....	6
Dimensions.....	9

# AC Power Regulators APR-D series

## 3-phase AC power regulators APR-D series

### ■ Description

The three-phase APR-D series products are successors of APR-L. Whereas their functions and performance have been largely improved due to incorporation of a CPU, space saving, less wiring, and inexpensive cost have been achieved.

### ■ Features

- Adopting the thyristor normal/reverse parallel method (6 arms).
- The output range is 0 to 100% of the main-circuit line voltage. Where the voltage drop portion due to thyristor-specific resistance is excluded.
- You can also switch the waveform control method among phase control, cycle control, and phase angle proportion control.

#### Phase control method (0 to 100%)

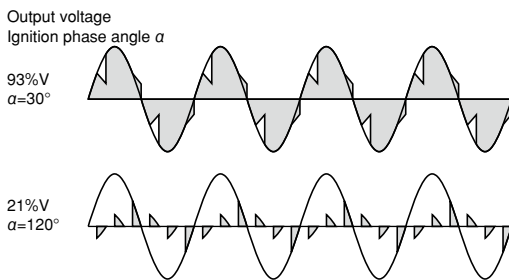

#### Cycle control method (Continuous)

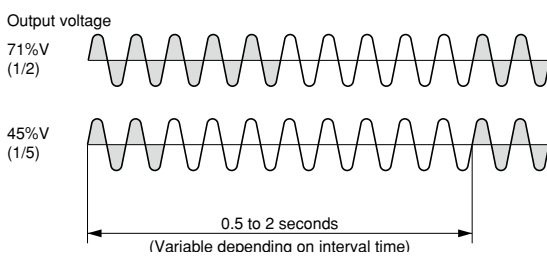

- The main-circuit terminal block has a cover attached.
- The mounting pitch is the same as for APR-L. Where 400 V, 45/60 A products are excluded.
- Output regarding individual settings represents linear characteristics of RMS values.

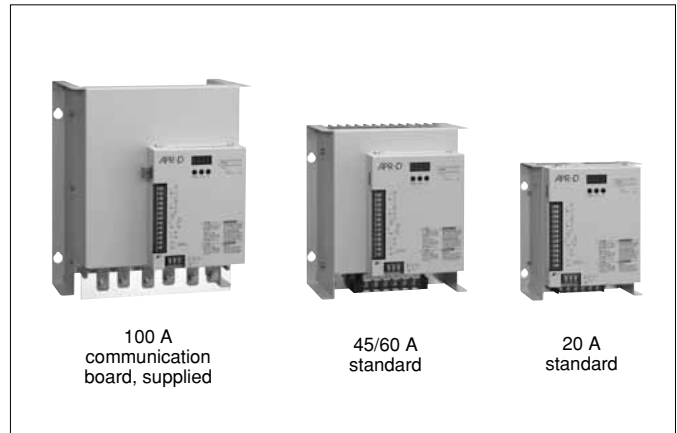

- Base load setting, digital settings including inclination setting, and monitor functions are available as part of the standard configuration.

#### Operation example

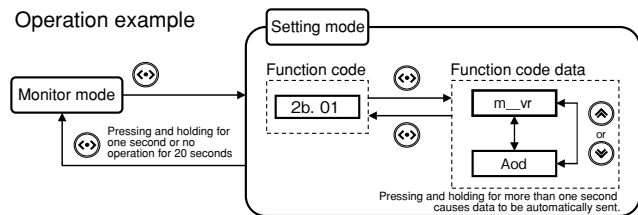

- Allows soft start time, soft up time, and soft down time to be discretely set in the range of 0 seconds to 100.0 seconds.
- When power to the main-circuit is turned On, soft start is always activated.
- The line voltage ranges are 200 to 240 V AC and 380 to 480 V AC.  
Note: An operational transformer is supplied with 380-440 V AC products. An operational transformer for 380-480 V AC products is an option.
- Allows communication control as an optional function.  
Option type of the main unit:  
ZAP: Up to 50 units can be operated in parallel.  
For cycle control, a flicker prevention function is available.  
ZAM: Various settings and monitors are possible by means of RS485 (Modbus RTU).
- All models of the APR units satisfy the CE marking. As for 400 V products, the operational transformer needs to be modified so that the CE marking is satisfied.



■ Type number nomenclature

RPD W 2 0 6 0 – T 1 – Z A P – 0 2 (Note 1)

Product category

Product	Code
APR-D series	RPD

Number of phases

Number of phases	Code
Three phases	W

Input voltage

Input voltage	Code
200 to 240V	2
380 to 440V, 380 to 480V	4 (Note 5)

The main unit supports 380-480 V.

Rated current

Rated current	Code
20A	020
45A	045
60A	060
100A	100

Others

Others	Code
No specification	Blank
No operational transformer	01
Test report (both Japanese and English), attached	02
No operational transformer plus test report, attached	03

The test report is generated in Fuji Electric's standard format. When specified by a customer, special specifications (Z) are produced. This is not shown as the type of the main unit.

Specifications

Specifications	Code
Standard	Blank
Option of the main unit	Z** (Note 3)

Setting device (Note 2)

Setting device	Code
No	Blank
Setting device: 1 set	1
Setting device: 2 sets	2
Setting device: 3 sets	3

Control method

Control method	Code
No feedback function	T

Note 1: For the order codes which are blank, put no space, immediately followed by a hyphen.  
 Note 2: One set of setting device is composed of a variable resistor, nameplate, control knob, and attachment sheet. The format of a separate order is "RPD001". This is not shown as the type of the main unit.  
 Note 3: Option of the main unit (Example)

Option specification names	Description	Type
Communication board (For parallel run)	Mounting a communication board for parallel run, equipped with a flicker prevention function (Note 4)	RPDW□□□□-T■-ZAP
Communication board (For network connections)	Mounting a communication board for Modbus RTU	RPDW□□□□-T■-ZAM

Note 4: The parallel run function provided by this communication board is not compatible with models other than the APR-D series. Cycle control with a single-phase product is not possible.  
 Note 5: For input voltage code "4", an operational transformer (ML3C2954) is supplied as part of the standard configuration. For products which support 480 V or CE marking, add "-01" to the main unit's type and separately order "TR3-300R/UL".  
 Order format example: RPDW4020-T1-01

Name	Transformer type	Rating (Primary voltage/ secondary voltage, capacity)
Operational transformer (Standard)	ML3C2954	380, 400, 440V/210V 20VA
Operational transformer (480 V supported)	TR3-300R/UL	380, 400, 440, 480V/220V 300VA

■ Types and ratings

Number of phases	Input voltage	Output current (A)	Type
Three phases	200 to 240V	20	RPDW2020-T
		45	RPDW2045-T
		60	RPDW2060-T
	380 to 440V	100	RPDW2100-T
		20	RPDW4020-T
		45	RPDW4045-T
	60	RPDW4060-T	
	100	RPDW4100-T	

Note: The price does not include a setting device and the main unit's options.

■ Important notes for selections

• Allowed load current/ ambient temperature characteristics

The standard rated current value is the one at an ambient temperature of 40°C. When it exceeds 40°C, reduce the load current as below:

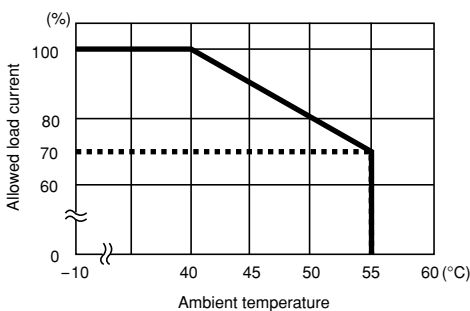

• Options of the main unit

After delivery, addition and alternation are not allowed for the type (product code). Please remember this when making an order.

• Rapid fuse

The main circuit does not contain a fuse. Use a Rapid fuse depending on the capacity.

• Important notes for power cycle life expectancy

If run and stop are repeated at short-period cycles (for example, 30-minute run and 30-minute stop), a large difference in temperature occurs in the thyristor element, significantly shorting its life expectancy through thermal fatigue. If such operations need to be performed, try to minimize the temperature fluctuation. Specifically, reduce the use rate of rated current to less than 80%. Or, choose an APR whose rated current is one level higher, so that the use rate of rated current is less than 80%.

# AC Power Regulators

## APR-D series

### ■ Specifications

Item		Specifications			
Type		RPDW□020-T	RPDW□045-T	RPDW□060-T	RPDW□100-T
Input	Number of phases	Three phases			
	Main circuit	Rated voltage	200 to 240 V AC $\pm 10\%$ (Performance guarantee), $\pm 15\%$ (Operation guarantee) (Note 1) 380 to 480 V AC $\pm 10\%$ (Performance guarantee), $\pm 15\%$ (Operation guarantee) (Note 1)		
		Frequency	50 Hz/ 60 Hz $\pm 2.5$ Hz (Must be the same as that of the control circuit.)		
Output	Control circuit	Rated voltage	200 to 240 V AC $\pm 10\%$ (Performance guarantee), $\pm 15\%$ (Operation guarantee) (Note 1)		
		Frequency	50 Hz/ 60 Hz $\pm 2.5$ Hz (Auto identification)		
		Power supply capacity	15 VA or less		
	Rated current (Ambient temperature: 40°C)	20A	45A	60A	100A
	Cooling system	Self-cooled			
	Applied load	Resistive load			
	Minimum load current	0.5 A (With 100% output of the rated input voltage)			
Control	Generation loss	75W	155W	196W	317W
	Waveform control method	Phase control/ cycle control (continuous)/ phase angle proportion control			
	Output voltage adjustment range	0 to 100% (RMS value) of the main-circuit line voltage (Where the voltage drop portion of the thyristor is excluded.)			
	Input/output characteristics		Linear characteristic of RMS value/ linearity: $\pm 3\%$ FS or less (phase control) Linearity: $\pm 5\%$ FS or less (cycle control) (With resistive load/ setting signal 10% to 90%)		
	Setting signal	Manual setting	Digital setting: Setting with front keys External variable resistor: 1 k $\Omega$ (B characteristics 1/2 W or more) HIGH/LOW (2-position control) contact signal: Digital setting through external wiring or front keys		
		Auto setting	Current signal: 4 to 20 mA DC (Zin = 100 $\Omega$ ) Voltage signal: 0 to 5 V DC (SSC signal: 0/12 V DC), 1 to 5 V DC (Zin = 11 k $\Omega$ ) (Setting change with front keys)		
	Gradient setting	Setting range	0 to 100% of output voltage		
		Setting equipment	Digital setting: Setting with front keys External variable resistor: 1 k $\Omega$ (B characteristics 1/2 W or more) Control input terminal "5V-M0" voltage signal: 1 to 5 V DC		
	Base load setting	Setting range	0 to 100% of output voltage		
		Setting equipment	Digital setting: Setting with front keys		
	Soft start, up/down time	Setting range	0 to 100 seconds		
		Setting equipment	Digital setting: Setting with front keys		
	Scanning interval setting	Setting range	0.5 to 2.0 seconds		
		Setting equipment	Digital setting: Setting with front keys		
	Alarm function	CPU memory error	CPU memory error detection at the time of initiation		
Power supply frequency failure		Detection of control power frequency outside the range from 45 to 65 Hz			
Auto setting input, not connected (Note 2)		Detection of non-connection of current and voltage signals (Only with auto setting chosen for setting signals)			
Manual setting input, not connected		Detection of non-connection of a manual setting device (Only with external variable resistor chosen regarding manual setting)			
Gradient setting input, not connected		Detection of non-connection of an gradient setting device (Only with an external variable resistor or 1 to 5 V DC chosen regarding the gradient setting)			
Open phase/ phase sequence failure		Detection of open phase or phase sequence failure regarding the main-circuit power and control power			
Data writing/reading error		Detection of read/write check errors regarding EEPROM			
Communication failure (Note 3)		Detection of data transmission failure when in parallel run or network communications			
Alarm output		Open collector 24 V DC/ 0.1 A 1 circuit			
Operational environment	Ambient temperature	-10°C to +55°C (When +40°C is exceeded, the load current is to be reduced.)			
	Storage temperature	-20°C to +60°C			
	Ambient humidity	+5 to +95%Rh (There must be no condensation.)			
	Others	There must be no action and vibration which induce corrosive gas (sulfurized gas, ammonia gas, etc.), fine particles, and insulation deterioration. Indoor, 1000 m or less altitude			
Insulation	Dielectric strength (Between the main circuit and the earth)	2 kV AC, 1 minute (200 to 240 V); 2.5 kV AC, 1 minute (380 to 480 V)			
	Insulation resistance (with the earth)	10 M $\Omega$ or more with 500 V DC megger			

Note 1: Performance guarantee designates satisfying specifications and assuring proper run of the product. Operation guarantee designates assurance of damage-free parts and proper run of the product.

Note 2: No operation occurs when voltage signal 0 to 5 V DC (0/12 V) has been set.

Note 3: Option type: ZAP or ZAM only



## ■ Wiring diagram

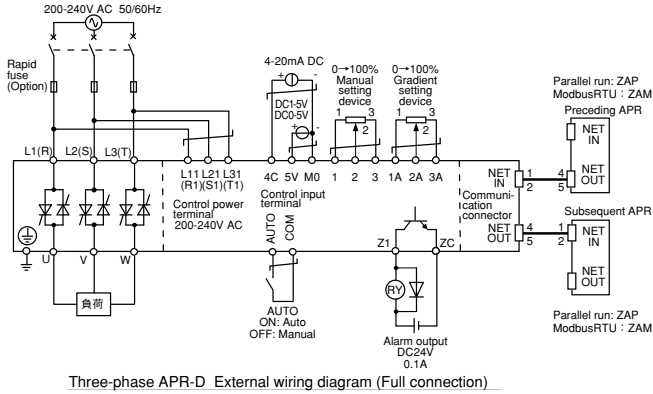

## • Positions and functions of connection terminals

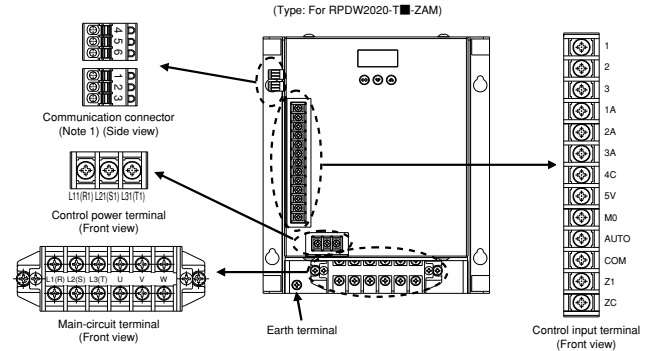

## • Wiring of the main-circuit terminals and control power terminals

(1) When the main-circuit voltage is 200 to 240 V AC, 50/60 Hz

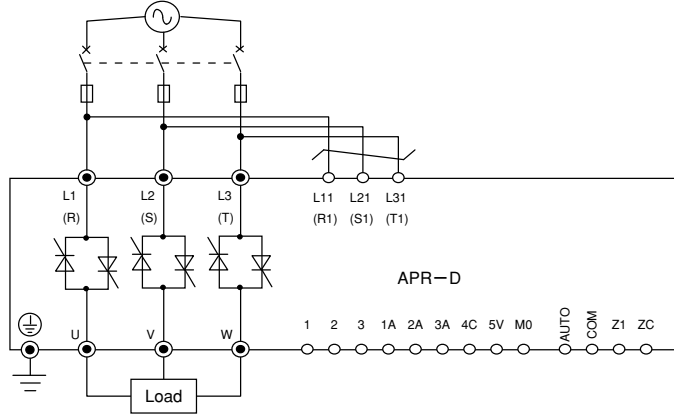

(2) When the main-circuit voltage is 380 to 440 V AC or 380 to 480 V AC, 50/60 Hz

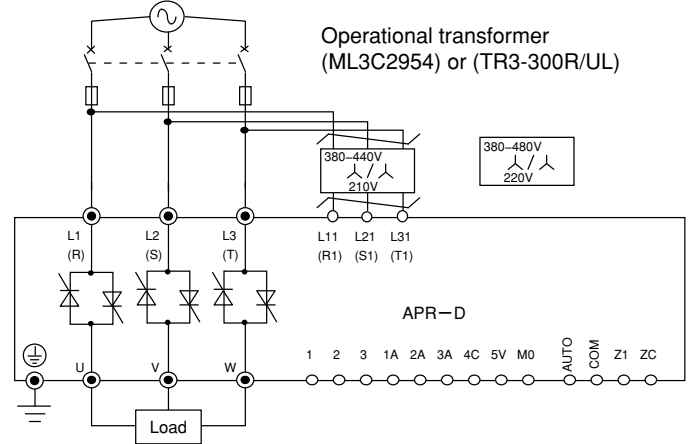

## • Screw size and tightening torque

Terminal		Screw size	Tightening torque [N·m]±10%
Main-circuit terminal	L1 (R), U L2 (S), V L3 (T), W	20A product	M4 1.8 (18kgf·cm)
		45A product	M5 3.5 (35kgf·cm)
		60A product	M6 5.8 (58kgf·cm)
		100A product	M8 13.5 (135kgf·cm)
Earth terminal	⊕	20A product	M4 1.8 (18kgf·cm)
		45/60A product	M5 3.5 (35kgf·cm)
		100A product	M6 5.8 (58kgf·cm)
Control power terminal	L11 (R1), L21 (S1), L31 (T1)	20-100A product	M3 0.5 (5kgf·cm)
Control input connector	1 to ZC	-	M3 0.5 (5kgf·cm)
Communication connector	NET IN, NET OUT	-	-
Main-unit mounting screw		20A product	M4 1.8 (18kgf·cm)
		45/60A product	M5 3.5 (35kgf·cm)
		100A product	M6 5.8 (58kgf·cm)

# AC Power Regulators

## APR-D series

### • Terminal function

Terminal	Pin	Symbol	Name	Function description	
Main-circuit terminal	—	L1 (R), L2 (S), L3 (T)	Main-circuit input terminal	Three-phase power input for the main circuit	
	—	U, V, W	Main-circuit output terminal	APR output Connection of three-phase load	
Earth terminal	—	⊕	Earth terminal	Earth terminal of the main unit	
Control power terminal	—	L11 (R1) L21 (S1) L31 (T1)	Control power terminal	Power supply three-phase 200 to 240V input for the control circuit	
Control input terminal	—	1, 2, 3	Manual setting input	Manual setting input through a variable resistor	
	—	1A, 2A, 3A	Gradient setting input	Gradient setting input through a variable resistor	
	—	4C, M0	Auto setting input	Auto setting input through 4 to 20mA DC	
	—	5V, M0		Auto setting input or gradient setting input through 1 to 5V DC Auto setting input (SSC signal input) through 0 to 5V DC (0/12V)	
	—	AUTO, COM	Auto/manual switching input	External contact Close: Auto setting Open: Manual setting	
Communication connector	Net-work	1-2	NET IN	RS-485 input	Data reception/transmission from/to the master equipment
		4-5	NET OUT	RS-485 output	Connection with slave equipment or connection of a terminating resistor
	Parallel run	1-2	NET IN	Parallel run input	Data reception from the preceding APR
		4-5	NET OUT	Parallel run output	Data transmission to the subsequent APR

### ■ Other options

#### • Rapid fuse application table

APR type	Rated current	Voltage line	Rapid fuse type	Rapid fuse holder
RPDW2020 RPDW4020	20A	200V 400V	CR2LS-30 (30A) CR6L-30 (30A)	CM-1A (For 3-pole products) CMS-4 (For 1-pole products)
RPDW2045 RPDW4045	45A	200V 400V	CR2LS-75 (75A) CR6L-75 (75A)	CM-1A (For 3-pole products) CMS-5 (For 1-pole products)
RPDW2060 RPDW4060	60A	200V 400V	CR2LS-100 (100A) CR6L-100 (100A)	CM-1A (For 3-pole products) CMS-5 (For 1-pole products)
RPDW2100 RPDW4100	100A	200V 400V	CR2L-150 (150A) CR6L-150 (150A)	CM-2A (For 3-pole products) CMS-5 (For 1-pole products)

#### • Replacement adapter for APR-L (RPD002-W □□□)

Type	Description
RPD002-W06	For RPDW4045-□□, RPDW4060-□□

Note: Attach the adapter to the mounting holes (for APR-L) on the board, and then attach the APR-D to the adapter.

#### • Clamp tool, etc.

Recommended stick terminal for wiring; and clamp tool Manufacturer: PHOENIX CONTACT

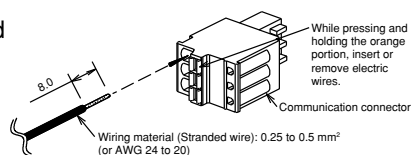

Product name	Type
Clamp tool	CRIMPFOX 6
Stick terminal with an insulating sleeve (AWG 24)	AI 0, 25-8 BU
Stick terminal with an insulating sleeve (AWG 22)	AI 0, 34-8 TQ
Stick terminal with an insulating sleeve (AWG 20)	AI 0, 5-8 WH

■ The standard configuration of the APR-D series contains display/operation sections for various monitors and settings.

• Names and functions of the individual parts

Name	Function	Name	Function
Drive monitor	Data display section 4th digit DP Run output Presence (lighting up)/ absence (going off)	UP key DOWN key	Use, for example, to select run information shown on the data display section and to change the function code data. * Press and hold for one second or longer to perform auto switch of the data display.
Data display	4-digit 7-segment LED monitor The information below is shown depending on the operation modes. • When in monitor mode Run information (Output instruction value, input signal, etc.) When an alarm is generated, an alarm code is shown. The 4th digit shows items regarding various pieces of run information. • When in setting mode Information such as a function code and function code data is shown.	MODE/ SET key	Use to switch the operation mode. Press and release to switch to the setting mode. • When selecting a function code in the setting mode Press and release to switch to function code data display. Press and hold for 1 second or longer to switch to the monitor mode. • When setting function code data in the setting mode Press and release to confirm data. Press and hold for 1 second or longer to cancel the setting and move to the monitor mode.
Alarm indicator	Data display section 1st digit DP Alarm Presence (blinking)/ absence (going off)		

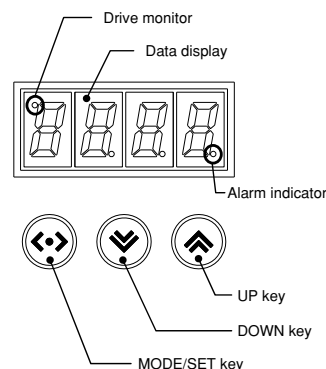

• Monitor mode

Operating the UP and DOWN keys causes the monitor items below to be shown. (The alarm code is shown only when a failure occurs.)

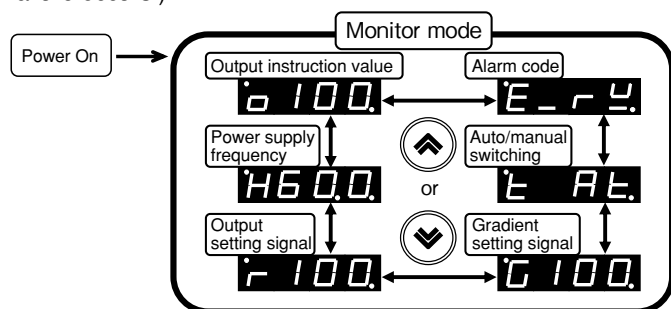

No	Monitor item	Function item display	Display	Unit	Display description
1	Output instruction value	o	100	%	Output instruction value through APR internal calculation
2	Power supply frequency	H	60.0	Hz	Power supply frequency detection value
3	Output setting signal	r	100	%	Setting signal detection value
4	Gradient setting signal	G	100	%	Gradient setting signal detection value
5	Auto/manual switching	t	At/m1	-	Auto/manual switching terminal status indication At: Auto setting m1: Manual setting
			Hi/Lo	-	Status indication regarding 2-position control Hi: HIGH setting Lo: LOW setting
6	Alarm code	E	_Sm	-	Indication when an alarm is generated (Example: Manual setting input non-connection)

• Setting mode

It is possible to set and confirm the data below, for each item:

Category	Display	Setting item	Description of the main functions
Data setting	1b._ _	Basic function 1 b code (1b.01 to 1b.07)	Setting to be used for basic APR operations Mainly substitute of external volume
	2b._ _	Basic function 2 b code (2b.01 to 2b.07)	Setting to be used for basic APR operations Mainly function selection
	4n._ _	Network function n code (4n.01 to 4n.08)	Communication relating setting
	5A._ _	Alarm function A code (5A.02 to 5A.09)	Alarm output setting
Setting option	6o._ _	Setting option function o code (6o.01 to 6o.04)	Utility function setting (For example, display of function codes changed from factory defaults and restriction of operations of the setting display section)
Initial setting	0i._ _	Initial setting function i code (0i.04 to 0i.05)	Communication protocol setting, ROM version check

Setting item	Setting signal	Function code	Function code data
Auto setting	Current signal	4–20mA DC	–
	Voltage signal	1–5V DC	2b.03 (Auto setting voltage signal selection)
		0–5V DC	
Manual setting	Setting indication section	2b.01 (Manual setting device selection)	Aod (Setting indication section)
	External variable resistor	1–2–3	m-vr (External variable resistor)
Gradient setting	Setting indication section	2b.02 (Gradient setting device selection)	Aod (Setting indication section)
	External variable resistor	1A–2A–3A	G-vr (External variable resistor)
	Voltage signal		5vm0 (Voltage setting signal)
Slave function (ZAP)	–	4n.01 (Master/slave selection)	no.2- (Slave)

# AC Power Regulators APR-D series

## • Example of setting groups

Function code	Name	Function code data (Settable range)	Step size	Unit	Factory default
1b.01	Manual digital setting	0 to 100.0(%)	0.1	%	0
1b.02	Gradient digital setting	0 to 200.0(%)	0.1	%	100.0
1b.03	Base load setting	0 to 100.0(%)	0.1	%	0
1b.04	Soft start time setting	0 to 100.0(second)	0.1	seconds	0.5
1b.05	Soft up time setting		0.1	seconds	0.5
1b.06	Soft down time setting		0.1	seconds	0.5

## • Gradient setting/ base load setting

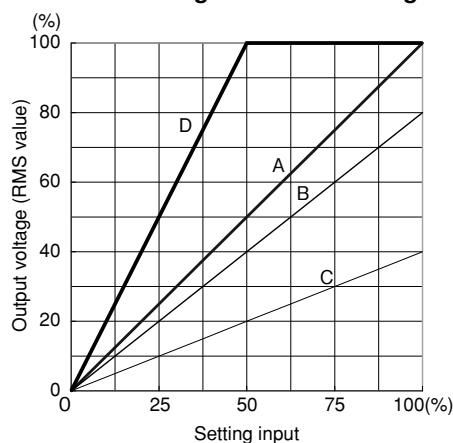

Characteristics	Output adjustment range (%)	Base load setting (%)	Gradient setting (%)
A	0 to 100	0	100
B	0 to 80	0	80
C	0 to 40	0	40
D	0 to 100	0	200

Gradient setting: Set an output value to be presented when setting input is 100%. (Setting range: 0 to 200%)  
Note: The upper limit output value is 100% of input voltage.

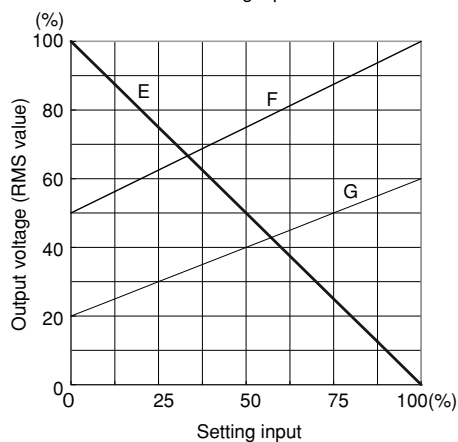

Characteristics	Output adjustment range (%)	Base load setting (%)	Gradient setting (%)
E	100 to 0	100	0
F	50 to 100	50	100
G	20 to 60	20	60

Base load: Set an output value to be presented when setting input is 0%. (Setting range: 0 to 100%)  
Actual output represents characteristics resulted from the connection between a base load setting value and gradient setting value using a straight line.

## ■ Dimensions, mm

### • Outline dimensions and mass

#### Outline dimensions

	20A	45A/60A	100A
W	185	240	291
H	215	265	345
D	135	170	215

Note: The outline dimensions of the 200 V series and 400 V series are identical.

#### Mass

	20A	45A/60A	100A
2.6kg	6.8kg	10.0kg	

Note: The mass of the 200 V series and 400 V series is identical.

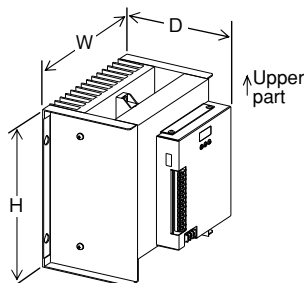

### • Mounting pitch (Drilling)

#### Mounting pitch

	20A	45A/60A	100A
A	170	222	270
B	145	165	245
C	185	240	291
D	215	265	345
E	7.5	9	10.5
F	35	50	50
Mounting screw	M4	M5	M6

Note: The outline dimensions of the 200 V series and 400 V series are identical.

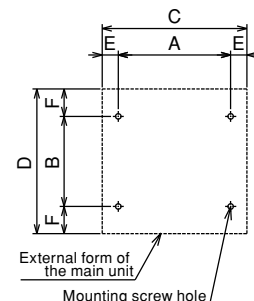

### • Supplied item (If specified in ordering information)

Setting device Type: RPD001 To be used for setting methods including variable resistor setting, 2-position control, and gradient setting.

Rating: 1 kΩJ, 2.5 W Type: RA30Y20SB102J (Manufacturer: TOKYO COSMOS)

Variable resistor

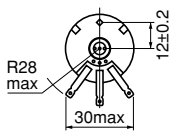
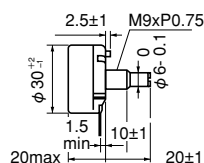

Mounting hole processing drawing

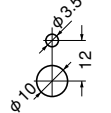

Nameplate

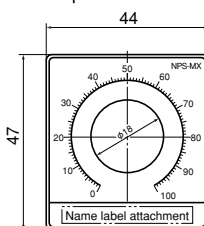

Knob

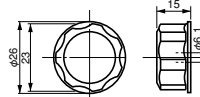

Name label sheet

(Japanese/English, 8 kinds)

手動設定	MANUAL SET.
勾配設定	GRADE SET.
HIGH設定	HIGH SET.
LOW設定	LOW SET.

Operational transformer Type: ML3C2954

To be supplied when the input voltage code is 4 Note: CE marking, not supported

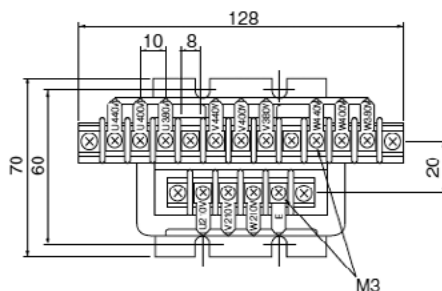
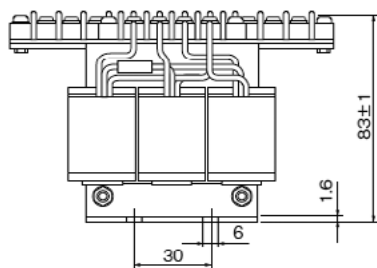

Output current	For 20 to 100 A
Rating	3φ, 380, 400, 440V/210V 20VA
Type	ML3C2954

Mass: 1.7 kg

Note: For TR3-300R/UL, which satisfies the CE marking, see the page for the APR-N series.

### ■ Important notes for installation

- Install in a dust-free place with high cooling effect. So that heat radiation from APRs is possible, mount to a vertical metal object, confirm the vertical orientation shown to the right, and ensure sufficient vertical and horizontal clearance among the units. If placing APRs closely one another, ensure sufficient clearance beyond the dimensions indicated in the Figure (shown to the right) to reduce heat interference among the APRs.
- Heat generation of an APR raises the temperature inside the panel. Considering expected temperature rise, implement measures such as cooling and ventilation. (The upper limit of temperature inside the panel is 55°C.) The reference ambient temperature for the rated current is 40°C. When it exceeds 40°C, reduce the load current.
- Ensure a clearance with nearby objects, considering the work space of wiring tools at the individual terminals.
- The top of an APR has a partial opening. Be careful not to drop any object into the opening.

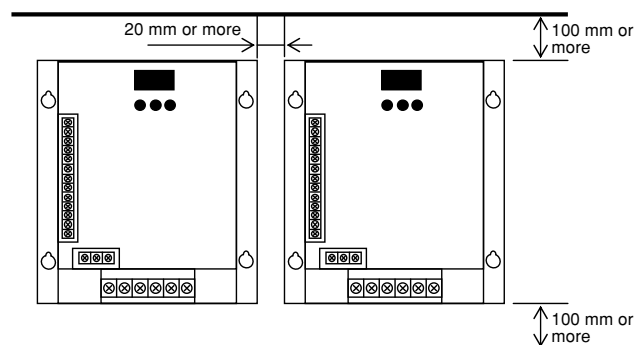

Installation interval

AC Power Regulators  
**APR-D series**

■ MEMO



## Safety Considerations

- Operate (keep) in the environment specified in the operating instructions and manual. High temperature, high humidity, condensation, dust, corrosive gases, oil, organic solvents, excessive vibration or shock might cause electric shock, fire, erratic operation or failure.
- For safe operation, before using the product read the instruction manual or user manual that comes with the product carefully or consult the Fuji sales representative from which you purchased the product.
- Products introduced in this catalog have not been designed or manufactured for such applications in a system or equipment that will affect human bodies or lives.
- Customers, who want to use the products introduced in this catalog for special systems or devices such as for atomic-energy control, aerospace use, medical use, passenger vehicle, and traffic control, are requested to consult with Fuji Electric FA.
- Customers are requested to prepare safety measures when they apply the products introduced in this catalog to such systems or facilities that will affect human lives or cause severe damage to property if the products become faulty.
- For safe operation, wiring should be conducted only by qualified engineers who have sufficient technical knowledge about electrical work or wiring.
- Follow the regulations of industrial wastes when the product is to be discarded.
- For further questions, please contact your Fuji sales representative or Fuji Electric FA.

 **Fuji Electric FA Components & Systems Co., Ltd.**

5-7, Nihonbashi Odemma-cho, Chuo-ku, Tokyo, 103-0011, Japan

URL <http://www.fujielectric.co.jp/fcs/eng>