

COMPACT TYPE GAS ANALYZER

DATA SHEET

ZSVF-2

OVERVIEW

The compact type gas analyzer (ZSVF) consists of an analyzing block (infrared sensor and oxygen sensor) and a sampling block.

For gas extractor, either simplified measurement (non-fixed type) or continuous measurement (fixed type) probe is selectable at option.

Because a single beam type high-sensitivity mass flow sensor is adopted for the infrared sensor, long-term stability and maintainability are excellent.

This analyzer is capable of simultaneously measuring max. 5 components among NO_x, SO₂, CO₂, CO, CH₄ and O₂ in sample gas, and is used for flue gas from stationary emission sources such as various boilers, garbage incinerators and heat treatment furnaces, and for plant cultivation and research-purpose chemical analysis.



FEATURES

1. Gas concentrations of 5 components measurable simultaneously and continuously (Note).

Concentrations of max. 4 gas components among NO_x, SO₂, CO₂, CO and CH₄ are continuously measurable with the infrared sensor, and that of O₂ is continuously measurable with a magnetic force or galvanic cell type oxygen sensor in combination with a full-fledged sampling block.

2. Standard with 3-range analyzer

Measurement can be performed over a broad range using the range selector key.

3. Compact type small and easy to use.

The analyzing block and sampling block are separated from each other to facilitate transport and installation.

Operation is easier because operation keys and display unit are all gathered in the analyzing block.

4. A rich variety of standard functions incorporated.

Auto zero calibration and auto drain discharge function are incorporated for ensuring an excellent maintainability.

Max. 8-channel outputs are allowed including instantaneous concentration value, O₂-corrected value, O₂-corrected moving average value and CP calculation value outputs.

(Note) To perform measurement continuously, the standard requirements for sample gas (shown on page 3) need to be met, and periodic draining, zero/span calibrations and membrane filter replacement are required.

SPECIFICATIONS

1. Standard Specifications

• Measuring system:

NO_x, SO₂, CO₂, CO and CH₄; Non-dispersive infrared absorption method with single light source and single beam (single beam method)

O₂; Magnetic force or galvanic cell method

• Measurable component and min./max. measuring range:

NO_x; 0 to 500 ppm / 0 to 5000 ppm

SO₂; 0 to 500 ppm / 0 to 1 %

CO₂; 0 to 200 ppm / 0 to 100 %

CO; 0 to 200 ppm / 0 to 100 %

CH₄; 0 to 1000 ppm / 0 to 100 %

O₂; 0 to 5 % / 0 to 25 %

Max. 5 components measurable including O₂

• Number of measuring ranges:

3 ranges

- Max. range ratio 1:5

• Warm-up time:

30 min after power-on

Provided with count-down timer indicating function.

• Analog output:

In up to 8 channels.

4 to 20 mA DC or 0 to 1 V DC (linear)

Non-isolated output

Allowable load; 4 to 20 mA DC, 550Ω or less 0 to 1 V DC, 100 kΩ or more

- Instantaneous value output of each gas component
- Instantaneous value output after O₂ correction (when provided with O₂ analyzer)

This product is not explosion-proof. When handling dangerous gas, adequate attention shall be paid.

- Average value output after O₂ correction (when provided with O₂ analyzer)
- CP calculation value output (when provided with CO₂ analyzer)
- * The channel numbers of indicated value and output value correspond to each other one by one.
- * An exclusive 25-pin cable is standard-equipped.
- **Communication output:**
RS-232C Modbus protocol
- * Use a commercially available product (D-sub 9-pin cable).
- **Control input/output:**
Input/output signals between the analyzing block and sampling block.
- * An exclusive 15-pin cable is standard-equipped.
- **Indicated values:**
Digital 4-digit indication (by LCD with back light)
 - Instantaneous values of respective gas components
 - Instantaneous values after O₂ correction (when provided with O₂ analyzer)
 - Average value after O₂ correction (when provided with O₂ analyzer)
 - CP calculation value display (when provided with CO₂ analyzer)
- * The channel numbers of indicated value and output value correspond to each other one by one.
- **Power supply:**
Rated voltage; 100 to 115 V AC or 200 to 240 V AC
Working voltage; 85 to 132 V AC or 180 to 264 V AC
- * Depending on customer's code selection.
Rated frequency; 50/60 Hz
Max. rated power; 150 VA for analyzing block
250 VA for sampling block
Inlet; Class 1 type conforming with EN60320
- **Operating conditions:**
Ambient temperature; 0 to 40°C
Ambient humidity; 90% RH or less
- * Condensation unallowable
- **Storage conditions:**
Ambient temperature; -20 to 60°C
Ambient humidity; 95% RH or less
- * Condensation unallowable.
Water should be drained from the drain pot and zero pot.
- **External dimensions (H × W × D mm):**
Analyzing block; 211 × 365 × 514
Sampling block; 377 × 365 × 514
- **Weight:**
Analyzing block; Approx. 12 kg
Sampling block; Approx. 18 kg
- **Finish color:**
Cover; White pearl mica
Base; Medium gray metallic
- **Enclosure design:**
Casing made of steel plates for indoor installation.
- **Gas-contacting part materials:**
Gas inlet/outlet; Polypropylene
Sample cell; SUS304/neoprene rubber
Transparent window; CaF₂
Internal pipes; Toalon tube/Teflon tube
Connection nipple; Polypropylene/Teflon
- **Gas inlet/outlet:**
ø6/ø3 hose end
- **Purge gas flow rate:**
1 L/min (to be purged as required)

2. Standard Functions

- **Auto zero calibration:**
Zero point is calibrated periodically at the predetermined cycle.
* For using N₂ gas, prepare zero cylinder gas.
Calibration cycle; OFF/ON (1 to 12 hours)
(settable in 1-hour step)
Gas flow time; 180 to 999 sec (settable in 1-sec step)
 - **Auto draining:**
Water is drained periodically at the predetermined cycle.
Draining cycle; 1 to 8 hours (settable in 1-hour step)
Draining time; 30 to 60 sec (settable in 1-sec step)
 - **Auto indication off:**
Indication automatically turns off when no key is operated for the determined period of time in the standby status.
Light off time; OFF/ON (1 to 30 min) (settable in 1-min step)
 - **Replacement/purge time:**
After zero/span calibration or measurement, zero gas or sample gas is automatically flowed.
Gas flow time; 30 to 300 sec (settable in 1-sec step)
 - **Output holding:**
At calibration during measurement, output holds the value just before the calibration according to hold setting. In the standby status, output will not be held.
Indication will not be held either.
Hold setting; OFF/ON
 - **Key lock:**
None of the set values can be changed when key lock is turned ON.
This is helpful for reducing operation errors and wrong inputs.
 - **Instrument/calibration error indication:**
When the instrument or calibration is abnormal, an error number is indicated to help analysis of the error.
 - **O₂ correction:**
Conversion of measured NO_x, SO₂ and CO gas concentrations into values at standard O₂ concentration
Calculating equation;

$$C = \frac{21 - O_n}{21 - O_s} \times C_s$$
 - C; Sample gas concentration after O₂ correction
 - C_s; Measured concentration of sample gas
 - O_s; Measured O₂ concentration
 - O_n; Standard O₂ concentration for conversion (settable within 0 to 19%)
- The result of conversion is indicated and output in a signal simultaneously.
- * An O_s value of 20% or more is taken as 20% for calculation.
 - **Averaging after O₂ correction;**
The result of O₂ correction is subjected to moving average for the determined period of time. And the result of averaging is indicated and output in a signal simultaneously. Average value will be taken at a cycle of 30 sec. (Indication and output are updated every 30 sec.)
 - **Resetting of output average value:**
Indication and output of average value are cleared in response to resetting.
* Effective only when average value selection is specified in CODE SYMBOLS.

• CP calculation:

The carbon potential of carburizing furnace and conversion furnace are calculated using furnace temperature (fixed input value) and CO concentration value (fixed or measured value) while referring to CO₂ measured value.

$$\text{Calculation equation; } CP = \frac{\text{CPS} \times (\text{PCO})^2}{K1 \times \text{PCO}_2}$$

where,

- CPS ; Saturated carbon concentration (partial pressure)
0.0028t–1.30 (800°C ≤ 850°C)
0.0030t–1.47 (850°C ≤ 950°C)
0.0034t–1.85 (950°C ≤ 1000°C)
- t ; Furnace temperature
- PCO ; CO concentration value (partial pressure)
- PCO₂ ; CO₂ concentration value (partial pressure)
- K1 ; Constant K1=10 (9.06–15966/T)
- T ; Rankine temperature (tx9/5+32+460)

3. Performance

• Repeatability:

Within ±0.5% of full scale

• Linearity:

Within ±2% of full scale

• Zero drift:

Within ±1% of full scale/day

• Span drift:

Within ±1% of full scale/day

• Response time:

Within 50 sec for 90% indication after extracting sample gas through the inlet.

However, within 3 min with SO₂ and galvanic cell type O₂ analyzers

• Other gases' influence:

Interference component concentration	Sample component/range	NOx analyzer		SO ₂ analyzer		CH ₄ analyzer
		500ppm max	1000ppm min	500ppm max	1000ppm min	All ranges
NO	1000ppm	—	—	Within ±2%		Within ±2%
SO ₂	1000ppm	Within ±2%		—	—	Within ±2%
CO ₂	15%	Within ±2%		Within ±2%		Within ±5%
CO	1000ppm	Within ±2%		Within ±2%		Within ±2%
CH ₄	1000ppm	Within ±2%		Within ±8%	Within ±5%	—
NH ₃	50ppm	Within ±8%	Within ±5%	Within ±8%	Within ±5%	Within ±2%
H ₂ O 2°C saturation		Within ±3%	Within ±2%	Within ±3%	Within ±2%	Within ±2%

* H₂O interference values in 2C saturation with NOx and SO₂ analyzers are values after moisture interference compensation.

Interference component concentration	Sample component/range	CO ₂ analyzer		CO analyzer		O ₂ analyzer
		200ppm max	500ppm min	200ppm max	500ppm min	All ranges
NO	1000ppm	Within ±2%		Within ±2%		Within ±2%
SO ₂	1000ppm	Within ±2%		Within ±2%		Within ±2%
CO ₂	15%	—	—	Within ±3%	Within ±3%	Within ±2%
CO	1000ppm	Within ±2%		—	—	Within ±2%
CH ₄	1000ppm	Within ±2%		Within ±2%		Within ±2%
NH ₃	50ppm	Within ±2%		Within ±2%		Within ±2%
H ₂ O 2°C saturation		Within ±3%	Within ±2%	Within ±3%	Within ±2%	Within ±2%

4. Standard Requirements for Sample Gas

• Flow rate:

0.5 L/min ±0.2 L/min for 1 optical system
(1 L/min ±0.4 L/min for 2 optical systems)

• Temperature:

0 to 40°C at inlet of sampling block
10 to 70°C at tip of non-fixed type probe (available at option)
70 to 400°C at tip of fixed type probe (available at option)

• Pressure:

0 to 3 kPa (Gas shall be discharged into atmospheric air.)

• Dust:

50 mg/Nm³ or less

• Mist:

Unallowable

• Corrosive gas:

HCl 10 ppm or less

Others Unallowable

• Standard gas for calibration:

Zero gas; N₂ or clean air

However, clean air cannot be used if CO₂ and O₂ are included in sample gas components.

Span gas; Concentration limited within 90 to 100% of the range of each sample gas component.
Unusable at concentrations beyond 100%.

5. Options

• Gas extractor:

Used for aspirating sample gas.

Non-fixed type; Since this type is used for intermittent measurement, it cannot be fixed.

Material;

SUS304/polypropylene

Fixed type; Used for continuous measurement. Flange 5K25A FF Sampling pipe length selectable among 300, 400, 600 and 800mm

Material; SUS316

• Sample inlet tube:

Used for delivering gas from the extractor to sampling block.

Shape; ø6/ø4 × 5 m or ø6/ø4 × 10 m

Material; Teflon

Installation Requirements

- Selection of a place which does not receive direct sunlight, rain, wind nor radiation from hot substances.
If such a place cannot be found, a roof or cover should be prepared for protection.
- Avoidance of a place under heavy vibration
- Selection of a place where atmospheric air is clean
- Discharge of exhaust gas into atmospheric air at a safe location
- Avoidance of use in an explosion-proof area

Scope of Delivery

- Gas analyzer system (analyzing and sampling blocks)
- Standard accessories (Refer to the table at top right table.)
- Instruction manual

Items to be Prepared Separately

- Standard gas (ZBM) and pressure regulator (ZBD)
- Recorder (when necessary, Fuji's product type PHR)
- 1-year spares for sampling equipment
(Refer to the table at bottom right table.)

Standard Accessories

Name	Quantity
Tubular fuse (2A)(for analyzing block)	2 pcs
Tubular fuse (2A)(for sampling block)	2 pcs
Power cord (for domestic use, for 100/115V AC) (2m) × 2 Power cord (for North American use, for 100/115V AC) (2m) × 2 Power cord (for European use, for 200/220V AC) (2m) × 2	Either one pair <small>* Depending on customer's code selection.</small>
Grounding cable (5m)	2 cables
Control signal cable (1m)	1 cable
Output signal cable (1m)	1 cable
Filter paper (Teflon) for membrane filter (when provided with SO ₂ analyzer)	4 sheets
Filter paper (glass fiber) for membrane filter (when not provided with SO ₂ analyzer)	10 sheets
Filter element for zero gas	2 pcs
Water container for zero gas	1 pc
Connection tube (5m)	1 tube
Instruction manual (in Japanese or English)	1 copy

Note) Standard accessories include consumables for 6 months.

Spare Parts for 1-Year Measurement

Name	Quantity	Ordering No.
Filter paper (Teflon) for membrane filter (when provided with SO ₂ analyzer)	12 sheets	TK741833P3
Filter paper (glass fiber) for membrane filter (when not provided with SO ₂ analyzer)	1 pc (25 sheets)	TK700735P2
Large O-ring for membrane filter	2 pcs	8553765
Small O-ring for membrane filter	2 pcs	TK733572P1
Filter element for zero gas	3 pcs	TK708816P1
Mist filter element	1 pc	TK7H8043P1
O-ring for mist filter	1 pc	8553765
Diaphragm unit for pump	4 units	TK713248P1
NO ₂ /NO converter catalyst (when provided with NO _x analyzer)	2 packs	TK726891C1
Glass wool for NO ₂ /NO converter (when provided with NO _x analyzer)	2 packs	TK726890C1
NO ₂ /NO converter joint (when provided with NO _x analyzer)	4 pcs	TK7G6890P1

For placing an order for all the spare parts for 1-year measurement, you are requested to select the following code symbols.

1 2 3 4 5 6 7 8								Description	
Z	B	N	1	S	V		1	NO _x analyzer	SO ₂ analyzer
							1	Without	Without
							2	With	Without
							3	Without	With
							4	With	With

Other

- A galvanic cell type oxygen sensor has a service life of about 18 months from the date of its delivery. Periodic replacement is recommended.

Replacement part ordering No. : TK7M3502C1

Principle Diagram of Infrared Type Measurement (NO, SO₂, CO₂, CO, CH₄)

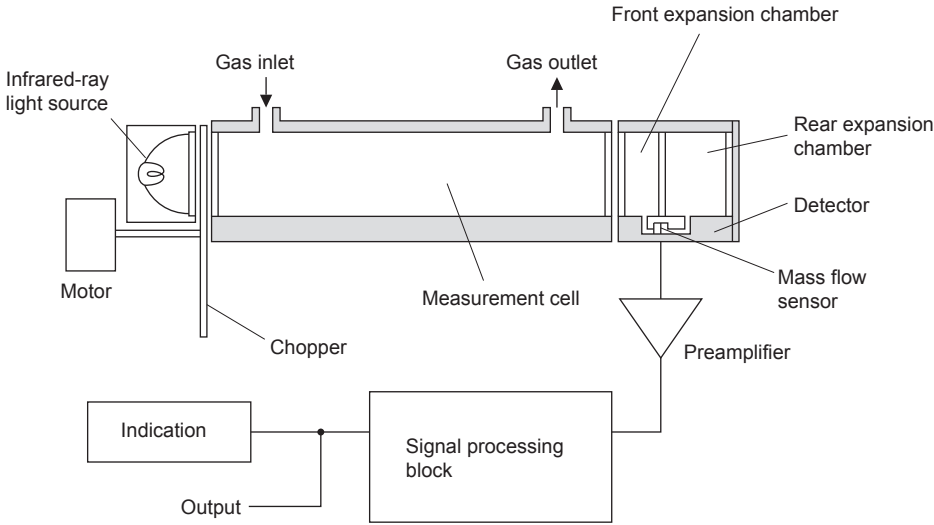

Principle Diagram of Magnetic Force Type Measurement (O₂)

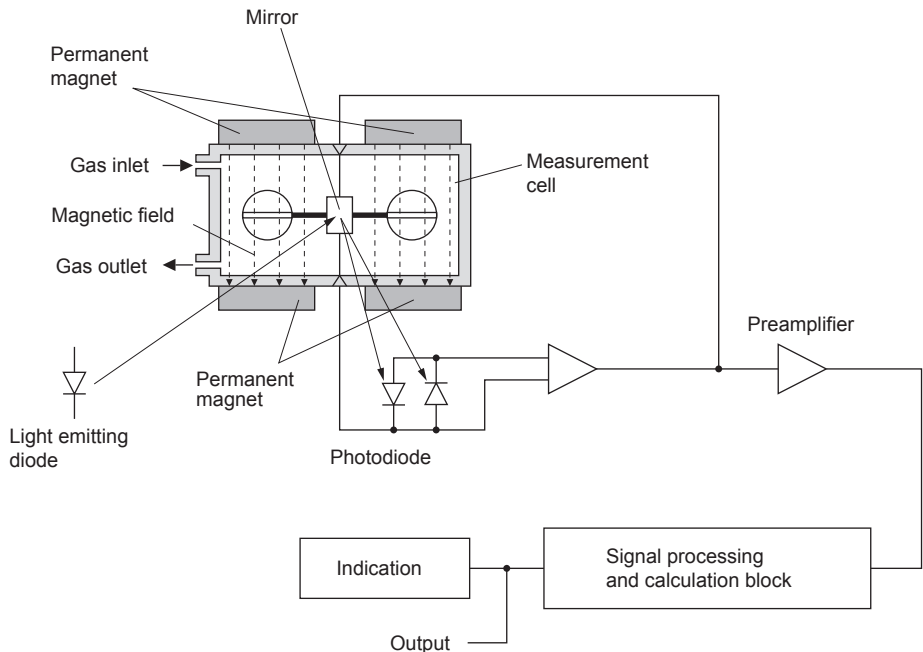

Principle Diagram of Galvanic Cell Type Measurement (O₂)

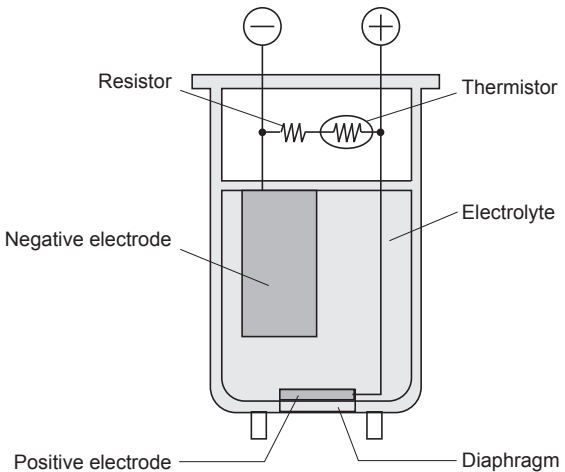

Tables of Sample Component and Measuring Range - Availability Check Tables -

Table 1: 1-Component Analyzer (NO_x, SO₂, CO₂, CO, CH₄)

Sample component Range		NO _x analyzer	SO ₂ analyzer	CO ₂ analyzer	CO analyzer	CH ₄ analyzer
		P	A	D	B	E
A	0 to 200/500/1000ppm	-	-	○	○	-
B	0 to 500/1000/2000ppm	○	○	○	○	-
C	0 to 1000/2000/5000ppm	○	○	○	○	○
D	0 to 2000/5000ppm/1%	-	○	○	○	○
E	0 to 5000ppm/1/2%	-	-	○	○	○
F	0 to 1/2/5%	-	-	○	○	○
G	0 to 2/5/10%	-	-	○	○	○
H	0 to 5/10/20%	-	-	○	○	○
J	0 to 10/20/50%	-	-	○	○	○
K	0 to 20/50/100%	-	-	○	○	○

○ : Product available

Table 2: 2-Component Analyzer (NO_x analyzer + SO₂ analyzer)

NO _x analyzer range SO ₂ analyzer range		Range values are the same as those of NO _x analyzer.									
		A	B	C	D	E	F	G	H	J	K
A	0 to 200/500/1000ppm	-	-	-	-	-	-	-	-	-	-
B	0 to 500/1000/2000ppm	-	○	○	○	-	-	-	-	-	-
C	0 to 1000/2000/5000ppm	-	○	○	○	-	-	-	-	-	-
D	0 to 2000/5000ppm/1%	-	-	-	-	-	-	-	-	-	-
E	0 to 5000ppm/1/2%	-	-	-	-	-	-	-	-	-	-
F	0 to 1/2/5%	-	-	-	-	-	-	-	-	-	-
G	0 to 2/5/10%	-	-	-	-	-	-	-	-	-	-
H	0 to 5/10/20%	-	-	-	-	-	-	-	-	-	-
J	0 to 10/20/50%	-	-	-	-	-	-	-	-	-	-
K	0 to 20/50/100%	-	-	-	-	-	-	-	-	-	-

○ : Product available

Table 3: 2-Component Analyzer (CO₂ analyzer + CO analyzer)

CO ₂ analyzer range CO analyzer range		Range values are the same as those of CO ₂ analyzer.									
		A	B	C	D	E	F	G	H	J	K
A	0 to 200/500/1000ppm	○	○	-	-	-	-	-	-	-	-
B	0 to 500/1000/2000ppm	○	○	○	-	-	-	-	-	-	-
C	0 to 1000/2000/5000ppm	-	-	○	○	-	-	-	-	-	-
D	0 to 2000/5000ppm/1%	-	○	○	○	○	-	-	-	-	-
E	0 to 5000ppm/1/2%	-	○	○	○	○	○	○	○	-	-
F	0 to 1/2/5%	○	○	○	○	○	○	○	○	○	-
G	0 to 2/5/10%	○	○	○	○	○	○	○	○	○	○
H	0 to 5/10/20%	○	○	○	○	○	○	○	○	○	○
J	0 to 10/20/50%	-	○	○	○	○	○	○	○	○	○
K	0 to 20/50/100%	-	○	○	○	○	○	○	○	○	○

○ : Product available

Table 4: 2-Component Analyzer (CH₄ analyzer + CO analyzer)

CO analyzer range CH ₄ analyzer range		Range values are the same as those of CH ₄ analyzer.									
		A	B	C	D	E	F	G	H	J	K
A	0 to 200/500/1000ppm	-	-	-	-	-	-	-	-	-	-
B	0 to 500/1000/2000ppm	-	-	-	-	-	-	-	-	-	-
C	0 to 1000/2000/5000ppm	-	-	-	-	-	-	-	-	-	-
D	0 to 2000/5000ppm/1%	-	-	-	-	-	-	-	-	-	-
E	0 to 5000ppm/1/2%	-	-	○	○	○	○	-	-	-	-
F	0 to 1/2/5%	-	-	○	○	○	○	○	○	-	-
G	0 to 2/5/10%	-	○	○	○	○	○	○	○	○	○
H	0 to 5/10/20%	-	○	○	○	○	○	○	○	○	○
J	0 to 10/20/50%	-	○	○	○	○	○	○	○	○	○
K	0 to 20/50/100%	-	○	○	○	○	○	○	○	○	○

○ : Product available

Table 5: 2-Component Analyzer (CO₂ analyzer + CH₄ analyzer)

CH ₄ analyzer range CO ₂ analyzer range		Range values are the same as those of CO ₂ analyzer.									
		A	B	C	D	E	F	G	H	J	K
A	0~200/500/1000ppm	-	-	-	-	-	-	-	-	-	-
B	0~500/1000/2000ppm	-	-	-	-	-	-	-	-	-	-
C	0~1000/2000/5000ppm	-	-	-	-	○	-	-	-	-	-
D	0~2000/5000ppm/1%	-	-	-	○	○	○	-	-	-	-
E	0~5000ppm/1/2%	-	-	-	○	○	○	○	-	-	-
F	0~1/2/5%	-	-	-	○	○	○	○	○	-	-
G	0~2/5/10%	-	-	-	○	○	○	○	○	○	-
H	0~5/10/20%	-	-	-	○	○	○	○	○	○	○
J	0~10/20/50%	-	-	-	○	○	○	○	○	○	○
K	0~20/50/100%	-	-	-	○	○	○	○	○	○	○

○ : Product available

- 2-component analyzer (NO_x analyzer + CO analyzer);
Possible range in combination of Table 1 (NO_x analyzer) and Table 1 (CO analyzer)
- 3-component analyzer (NO_x analyzer + SO₂ analyzer + CO analyzer);
Possible range in combination of Table 2 (NO_x analyzer + SO₂ analyzer) and Table 1 (CO analyzer)
- 3-component analyzer (NO_x analyzer + SO₂ analyzer + CO₂ analyzer);
Possible range in combination of Table 2 (NO_x analyzer + SO₂ analyzer) and Table 1 (CO₂ analyzer)
- 3-component analyzer (NO_x analyzer + CO₂ analyzer + CO analyzer);
Possible range in combination of Table 1 (NO_x analyzer) and Table 3 (CO₂ analyzer + CO analyzer)
- 3-component analyzer (SO₂ analyzer + CO₂ analyzer + CO analyzer);
Possible range in combination of Table 1 (SO₂ analyzer) and Table 3 (CO₂ analyzer + CO analyzer)
- 3-component analyzer (CH₄ analyzer + CO₂ analyzer + CO analyzer);
Possible range in combination of Table 1 (CH₄ analyzer) and Table 3 (CO₂ analyzer + CO analyzer)
- 4-component analyzer (NO_x analyzer + SO₂ analyzer + CO₂ analyzer + CO analyzer);
Possible range in combination of Table 2 (NO_x analyzer + SO₂ analyzer) and Table 3 (CO₂ analyzer + CO analyzer)

With 1 Optical System (1 to 3 component gas sampling system except for NOx analyzer)

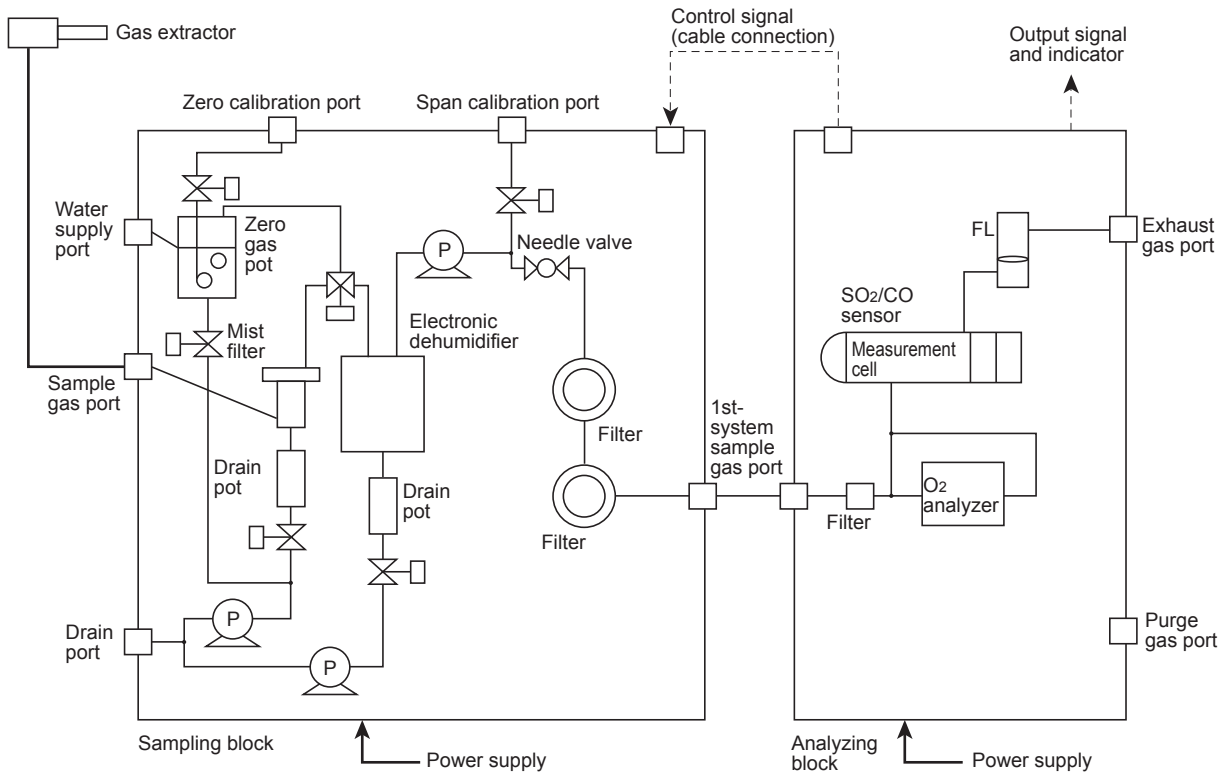

With 2 optical systems (3 to 4 component gas sampling system except for NOx analyzer)

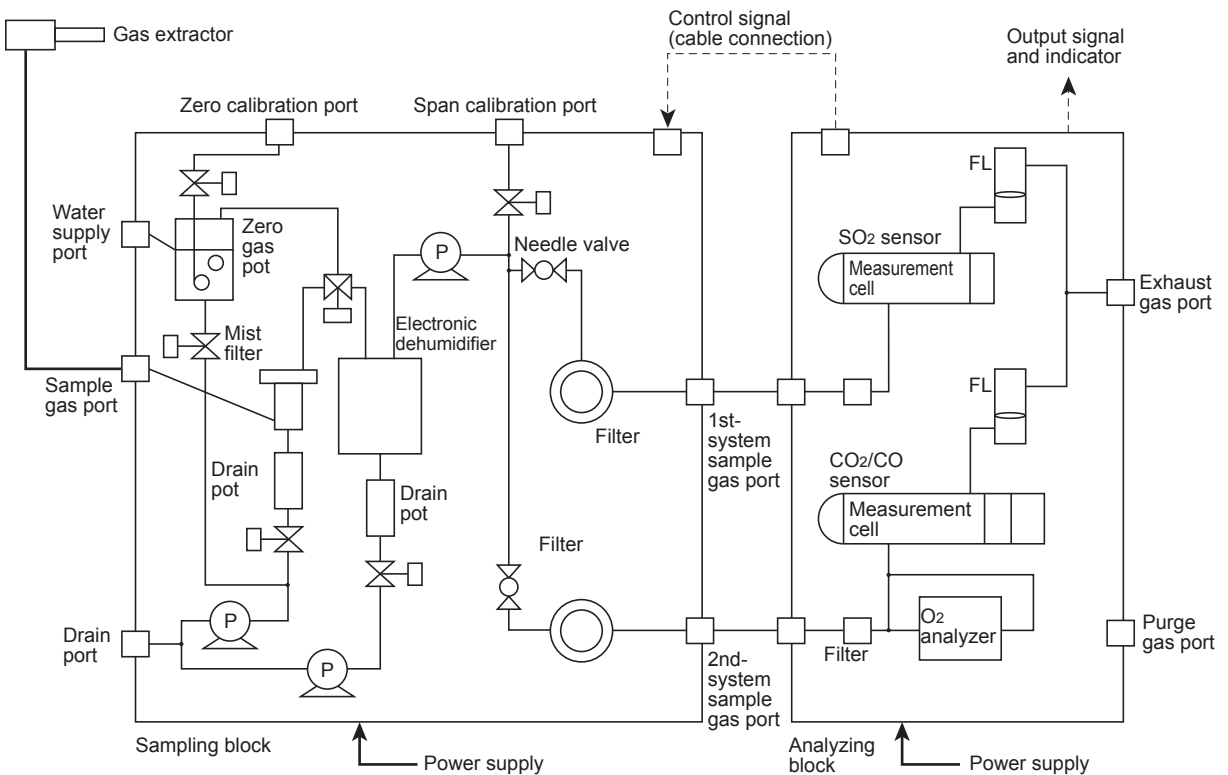

With 1 optical system (1 to 3 component gas sampling system including NOx analyzer)

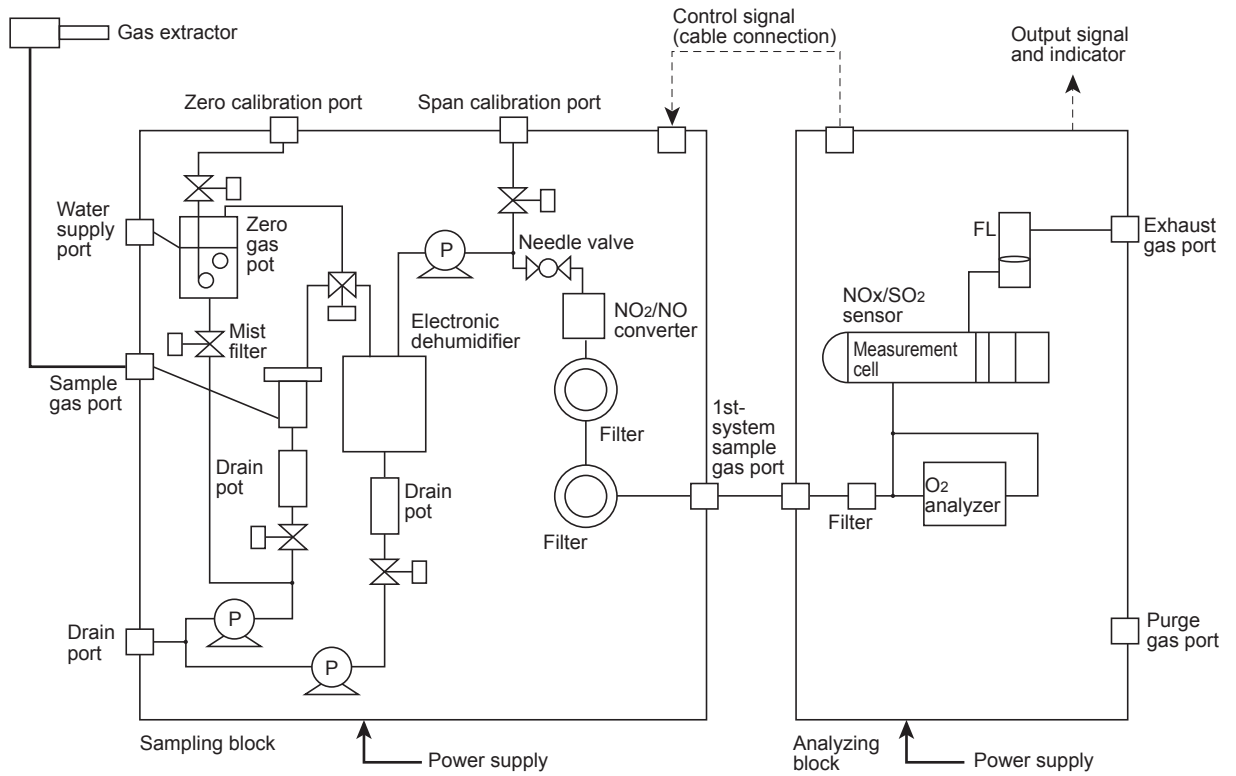

With 2 optical systems (3 to 5 component gas sampling system including NOx analyzer)

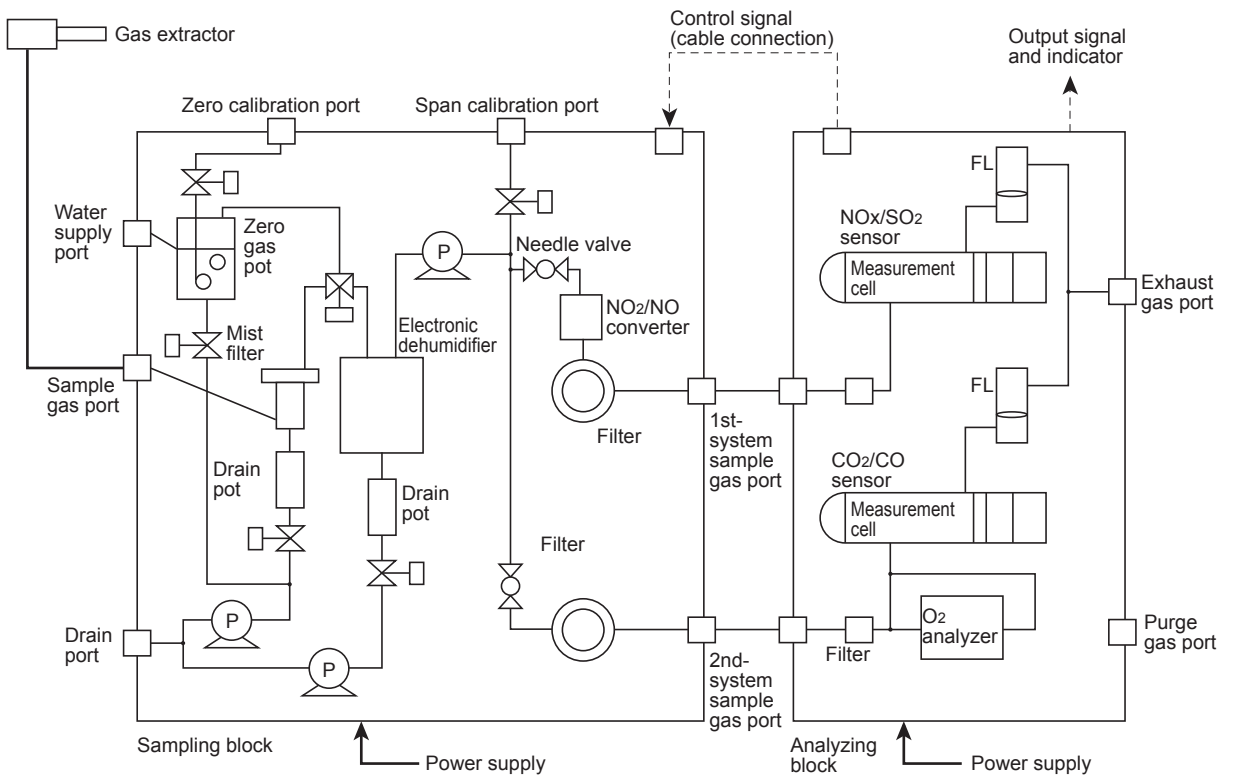

OUTLINE DIAGRAM (Unit : mm)

(1) Analyzing block

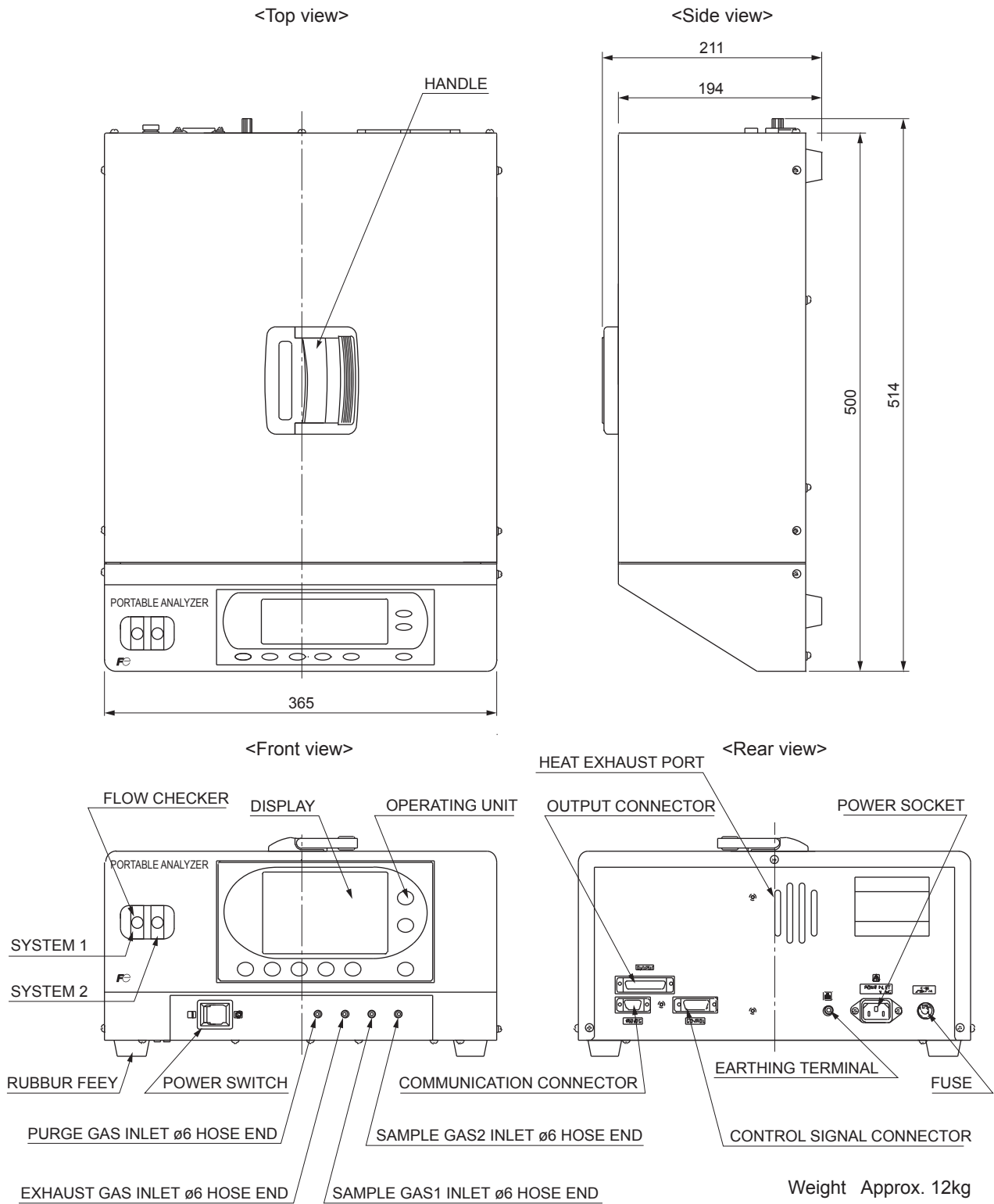

OUTLINE DIAGRAM (Unit : mm)

(2) Sampling block

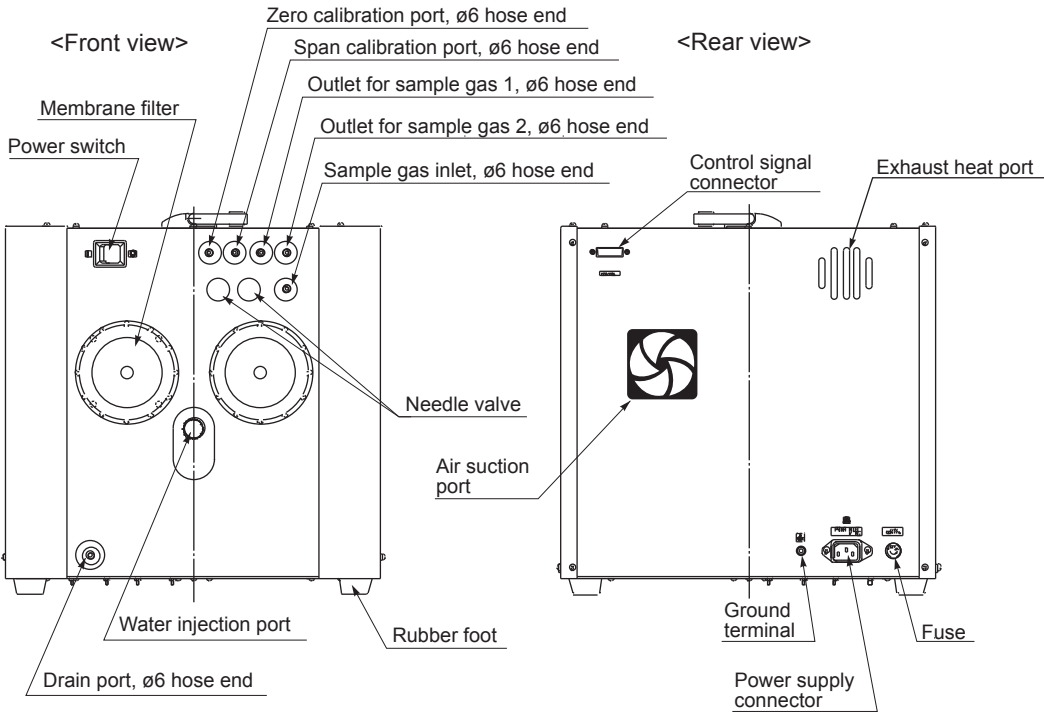
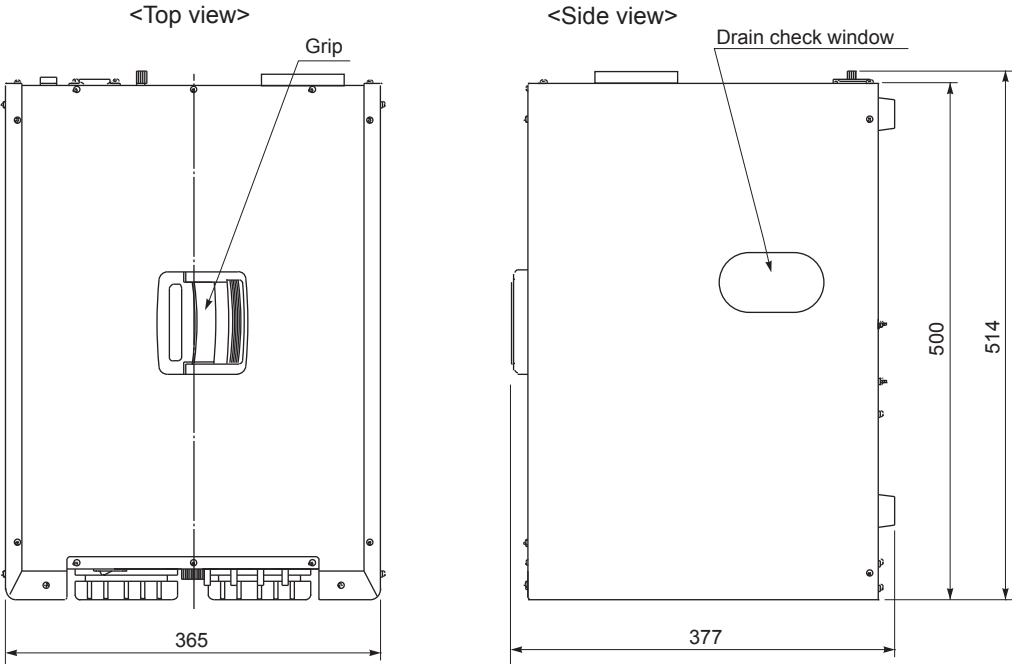

Weight Approx. 18kg

(3) External connection diagrams

Caution) Between male (P) and female (S) connectors, pin numbers are different.
Connect them properly with utmost care.

<Analyzing block Analog output>

On the analyzer side, a female connector (DB-25S-T-NR made by Japan Aviation Electronics Industry) is attached.
For connection, the furnished cables (1 m)(DB-25P) should be used.

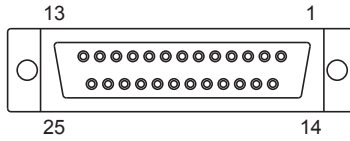

Color of furnished cable	Orange	Red	Brown	Black	White	Gray	Purple	Blue	Green	Yellow	Orange	Red	Brown
Pin name	CH7+	-CH6+	-CH5+	-CH4+	-CH3+	-CH2+	-CH1+						
Pin No.	13	12	11	10	9	8	7	6	5	4	3	2	1

Pin No.	25	24	23	22	21	20	19	18	17	16	15	14
Pin name	NC									-CH8+	-CH7	
Color of furnished cable										Blue	Green	Yellow

<Analyzing block Control output>

On the analyzer side, a female connector (DA-15S-T-NR made by Japan Aviation Electronics Industry) is attached.
For connection, the furnished cables (1 m)(DAU-15P) should be used.

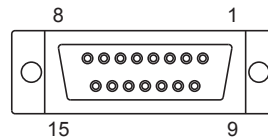

Pin name	SOLENOID VALVE2	SOLENOID VALVE1,6	DRAIN PUMP	SAMPLE PUMP
Pin No.	8	7	6	5

Pin No.	15	14	13	12	11	10	9
Pin name	NC	SOLENOID VALVE5	SOLENOID VALVE4	SOLENOID VALVE3			

<Analyzing block Communication output>

On the analyzer side, a male connector (DE-9P-T-NR made by Japan Aviation Electronics Industry) is attached.
For connection, commercially available cross cables (DE-9S) should be used.

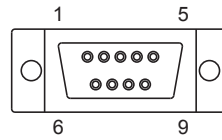

Pin name	NC	RXD	TXD	NC	GND
Pin No.	1	2	3	4	5

Pin No.	6	7	8	9
Pin name	NC	NC	NC	NC

<Sampling blockControl input>

On the analyzer side, a female connector (DA-15S-T-NR made by Japan Aviation Electronics Industry) is attached.
For connection, the furnished cables (1 m)(DAU-15P) should be used.

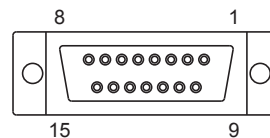

Pin name	SOLENOID VALVE2	SOLENOID VALVE1,6	DRAIN PUMP	SAMPLE PUMP
Pin No.	8	7	6	5

Pin No.	15	14	13	12	11	10	9
Pin name	NC	SOLENOID VALVE5	SOLENOID VALVE4	SOLENOID VALVE3			

OUTLINE DIAGRAM (Unit : mm)

(4) Power cord and signal cable

- Power cord for domestic and North American use (North American type), rated voltage 125V AC.
 Note: The standards for domestic and North American use are different, but the shape is the same.

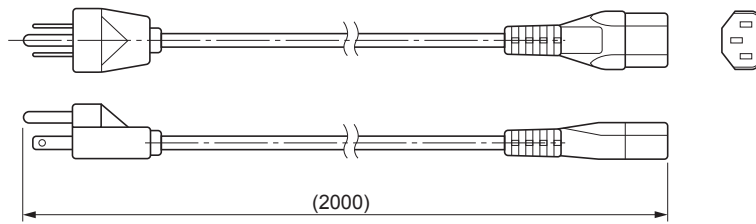

- Power cord for European use (European type), rated voltage 250 V AC

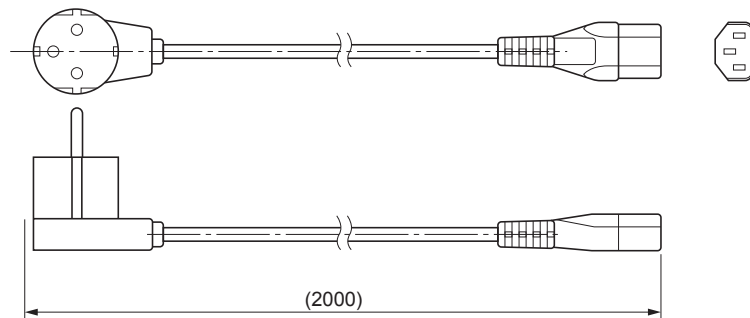

- Output cable

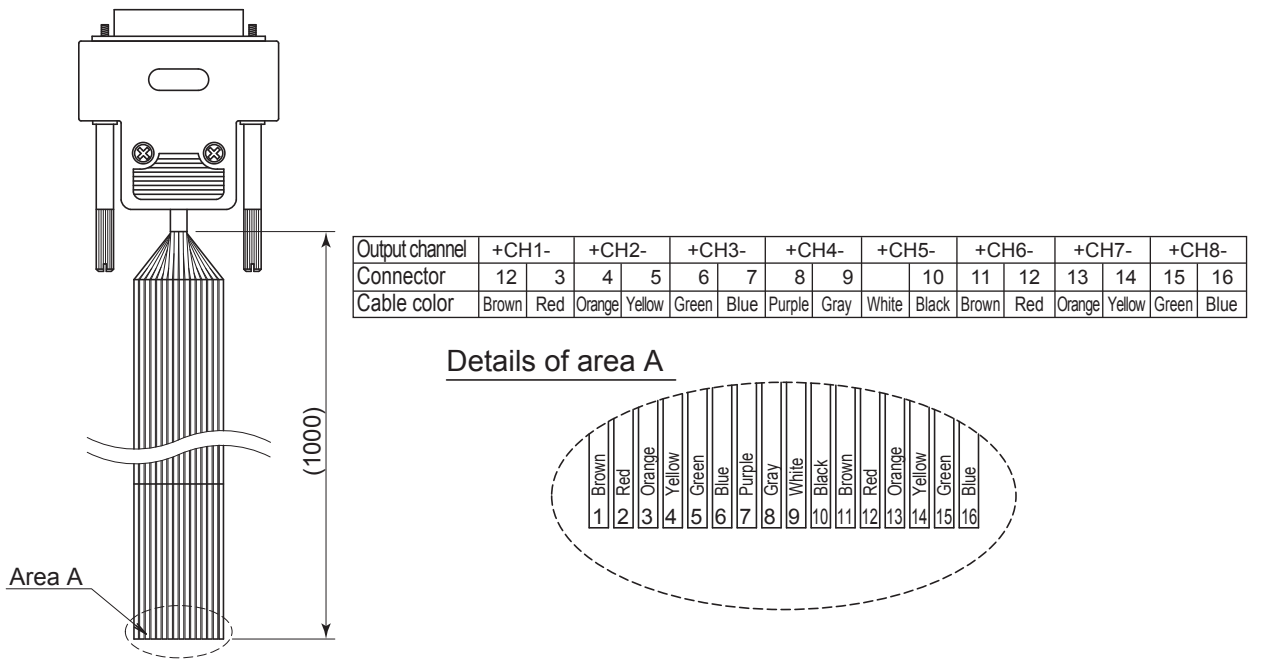

- Control input/output cable

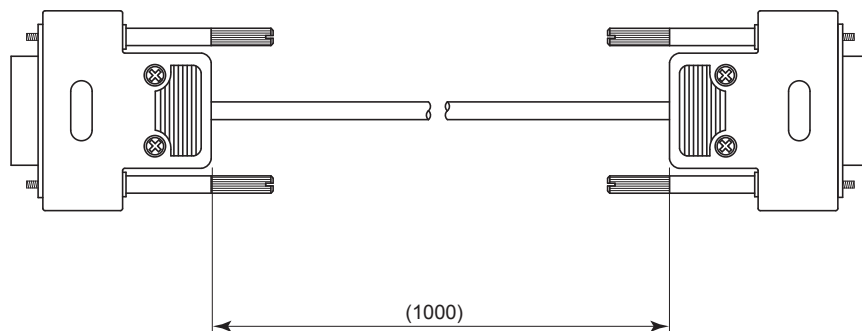

OUTLINE DIAGRAM (Unit : mm)

(5) Non-fixed type gas extractor

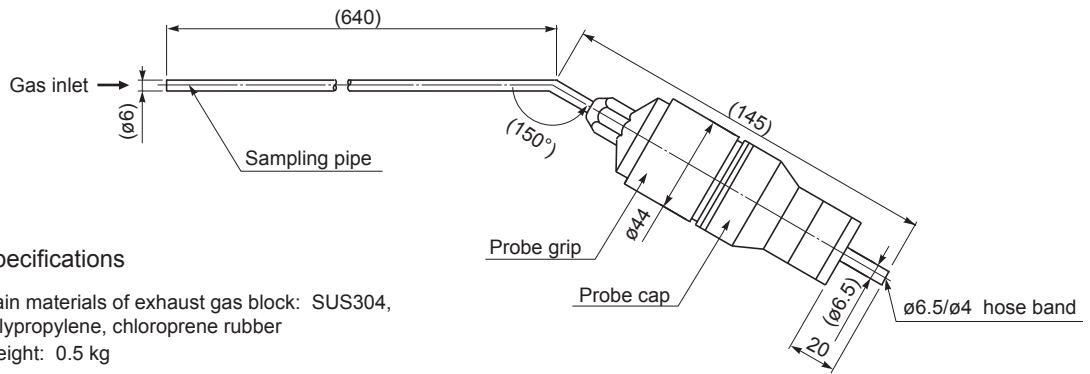

Specifications

Main materials of exhaust gas block: SUS304,
polypropylene, chloroprene rubber
Weight: 0.5 kg

(6) Fixed type gas extractor

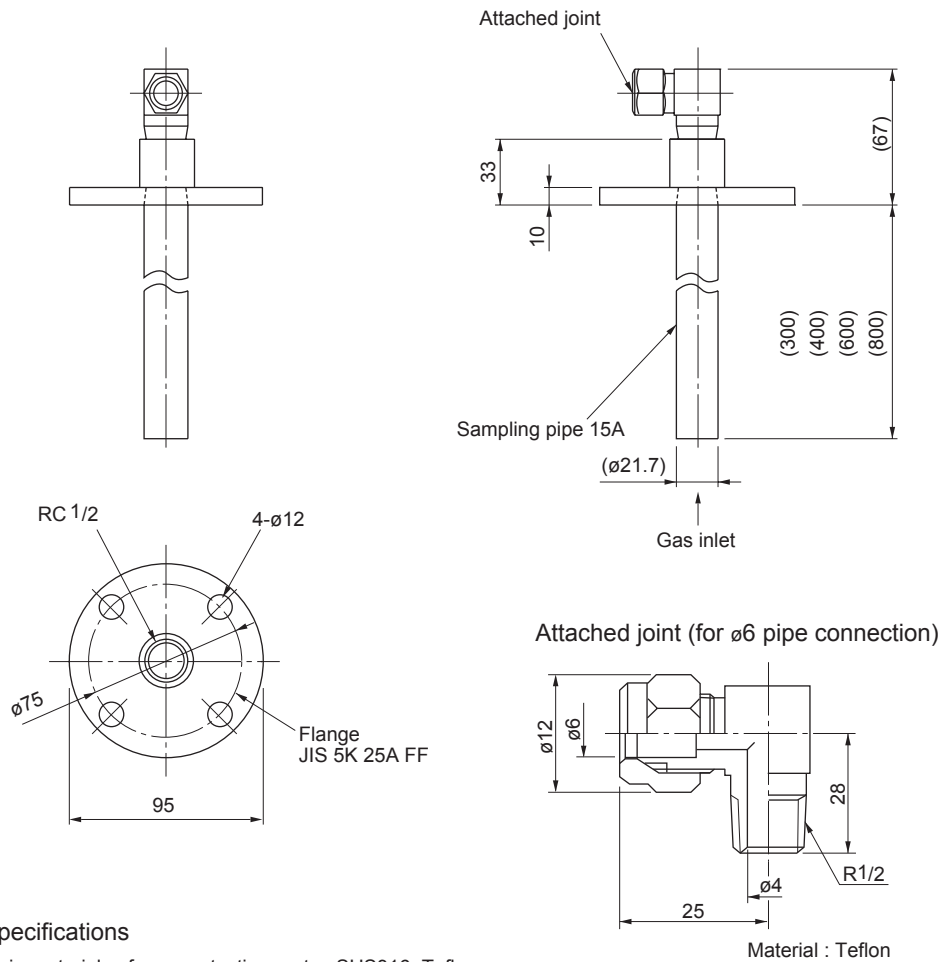

Specifications

Main materials of gas-contacting parts: SUS316, Teflon
Weight: 1 kg

⚠ Caution on Safety

*Before using this product, be sure to read its instruction manual.

F Fuji Electric Co., Ltd.

Global Sales Section
Instrumentation & Sensors Planning Dept.
1, Fuji-machi, Hino-city, Tokyo 191-8502, Japan
<http://www.fujielectric.com>
Phone: +81-42-514-8930 Fax: +81-42-583-8275
<http://www.fujielectric.com/products/instruments/>