

Space-saving Signal Conditioners M3-UNIT Series

RS-422 line driver pulse

FREQUENCY TRANSMITTER

(field- and PC-configurable)

Functions & Features

- Converts the output from a pulse-type transducer into a standard process signal
- Sensor excitation
- Easy 'One-Step Cal' calibration using the front three control buttons without needing a PC; PC software is also usable.
- Both input and output type and range are configurable
- Front control button function can be locked

Typical Applications

- Positive displacement flowmeters, turbine flowmeters and vortex flowmeters
- Measuring rotation speed of a machine generating dry contact signals

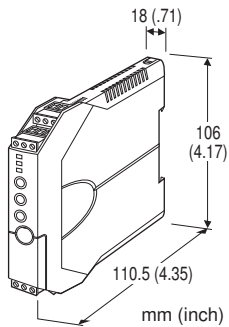

MODEL: M3LPA2-[1]/[2][3]

ORDERING INFORMATION

- Code number: M3LPA2-[1]/[2][3]
- Specify a code from below for each [1] through [3]. (e.g. M3LPA2-R4/A/Q)
- Specify the specification for option code /Q (e.g. /C01)
- Factory default setting:
 Input type: Open collector
 Frequency range: 0 - 100 kHz
 Sensor excitation: 12 V DC / 20 mA
 Output range: 4 - 20 mA
 Threshold: 2 V

INPUT - Field-selectable

- Open collector
- Mechanical contact
- Voltage pulse
- Two-wire current pulse

EXCITATION SELECTION

- 4 V DC / 20 mA
- 8 V DC / 20 mA
- 12 V DC / 20 mA

OUTPUT - Field-selectable

- Current**
0 - 20 mA DC
- Voltage**
-2.5 - +2.5 V DC
-10 - +10 V DC

[1] POWER INPUT

- AC Power**
M2: 100 - 240 V AC (Operational voltage range 85 - 264 V, 47 - 66 Hz)
('/UL' is not selectable for 'Standards & Approvals' code.)
- DC Power**
R4: 10 - 32 V DC
(Operational voltage range 9 - 36 V, ripple 10 %p-p max.)

[2] CONFIGURATION OPTIONS

- A: PC and field configurable
- B: Field configurable

[3] OPTIONS

- Standards & Approvals**
blank: CE marking
/UL: UL approval, CE marking
- Other Options**
blank: none
/Q: Option other than the above (specify the specification)

SPECIFICATIONS OF OPTION: Q

- COATING (For the detail, refer to M-System's web site.)**
/C01: Silicone coating
/C02: Polyurethane coating
/C03: Rubber coating (UL not available)

RELATED PRODUCTS

- PC configurator software (model: M3CFG)
Downloadable at M-System's web site.
A dedicated cable is required to connect the module to the PC. Please refer to the internet software download site or the users manual for the PC configurator for applicable cable types.

GENERAL SPECIFICATIONS

Construction: Small-sized front terminal structure

Connection: Euro type connector terminal
(applicable wire size: 0.2 to 2.5 mm², stripped length 8 mm)

Housing material: Flame-resistant resin (gray)

Isolation: Input to output to power

Overrange output: -15 to +115 %

Zero adjustment: -15 to +15 % (front)

Span adjustment: 85 to 115 % (front)

Status indicator LED: Tri-color (green/amber/red) LED;
Blinking patterns indicate operation status of the transmitter.

PC configurator: Programmable features include:

- I/O type and range, threshold
- Zero and span adjustments
- User's linearization table setting
(max. 101 points, specified within -15 to +115 % for both input and output)

- Sampling time (0.05 - 100 sec.)

(Refer to the instruction manual)

'One-Step Cal' calibration: With I/O type and the full-scale range configured via the internal DIP switches, precise 0 % and 100 % ranges are calibrated via the front control buttons with a help of LED. Also I/O calibration and fine adjustment are available with a PC.

Configurator connection: 2.5 dia. miniature jack;
RS-232-C level

INPUT SPECIFICATIONS

Measurable frequencies: Minimum span 10 % of the frequency range selected in Table 2. (5 % for 0 - 200 kHz range)

See each input type for the maximum span.

Pulse width time requirement: Min. 5 μsec., max. 10 sec.

■ Open Collector

Maximum frequency: 0 - 200 kHz

- Excitation: 4 V

Sensing voltage/current: Approx. 3V / 0.7 mA

Input requirements:

≤ 200 Ω / 0.2 V for ON; ≥ 2 kΩ / 1 V for OFF

Detecting level: 0.6 V

- Excitation: 8 V

Sensing voltage/current: Approx. 6V / 1.5 mA

Input requirements:

≤ 600 Ω / 1 V for ON; ≥ 4 kΩ / 3 V for OFF

Detecting level: 2 V

- Excitation: 12 V

Sensing voltage/current: Approx. 9V / 2.3 mA

Input requirements:

≤ 400 Ω / 1 V for ON; ≥ 2 kΩ / 3 V for OFF

Detecting level: 2 V

■ Mechanical Contact

Maximum frequency: 0 - 10 Hz

- Excitation: 4 V

Sensing voltage/current: Approx. 3V / 0.7 mA

Input requirements:

≤ 200 Ω / 0.2 V for ON; ≥ 2 kΩ / 1 V for OFF

Detecting level: 0.6 V

- Excitation: 8 V

Sensing voltage/current: Approx. 6V / 1.5 mA

Input requirements:

≤ 600 Ω / 1 V for ON; ≥ 4 kΩ / 3 V for OFF

Detecting level: 2 V

- Excitation: 12 V

Sensing voltage/current: Approx. 9V / 2.3 mA

Input requirements:

≤ 400 Ω / 1 V for ON; ≥ 2 kΩ / 3 V for OFF

Detecting level: 2 V

■ Voltage Pulse

Maximum frequency: 0 - 200 kHz

Waveform: Square or sine

Input impedance: ≥ 10 kΩ

Input amplitude: Min. 0.1 Vp-p, max. 100 V p-p
(30 V rms, 42.4 V peak or 60 V DC for UL approval)

Max. voltage between input terminals: 100 V
(30 V rms, 42.4 V peak or 60 V DC for UL approval)

Detecting levels: -2 - +4 V

(Detecting voltage in the internal circuit)

■ Two-wire Current Pulse

Maximum frequency: 0 - 200 kHz

Input resistance: Receiving resistor 100 Ω

Input range: 0 - 25 mA

Minimum pulse amplitude: 10 mA

Detecting levels: -2 - +4 V

(Detecting voltage in the internal circuit)

■ RS-422 Line Driver Pulse

Maximum frequency: 0 - 200 kHz

Receiver: Conforms to RS-422

OUTPUT SPECIFICATIONS

■ DC Current

Maximum range: 0 - 20 mA DC

Minimum span: 1 mA

Conformance range: 0 - 24 mA DC

(Negative overrange current below 0 mA is not available.)

Offset: Lower range can be any specific value within the output range provided that the minimum span is maintained.

Load resistance: Output drive 12 V maximum

■ DC Voltage

Narrow Spans

Maximum range: -2.5 - +2.5 V DC

Minimum span: 250 mV

Conformance range: -3 - +3 V DC

Wide Spans

Maximum range: -10 – +10 V DC

Minimum span: 1 V

Conformance range: -11.5 – +11.5 V DC

Offset: Lower range can be any specific value within the output range provided that the minimum span is maintained.

Load resistance: Output drive 1 mA maximum

INSTALLATION
Power Consumption
•AC:

Approx. 3 VA at 100 V

Approx. 4 VA at 200 V

Approx. 5 VA at 264 V

•DC: Approx. 3 W

Operating temperature: -25 to +65°C (-13 to +149°F)

Max. 55°C (131°F) for UL approval

Operating humidity: 0 to 95 %RH (non-condensing)

Mounting: DIN rail

Weight: 100 g (3.53 oz)

PERFORMANCE

Accuracy: Input accuracy + output accuracy

Input accuracy: ± 0.03 % of input range (Table 2)

Output accuracy: ± 0.03 % of output range (When the output span is not more than 2 mA, add 0.1 % to the accuracy)

The input accuracy is inversely proportional to the input span; while the output accuracy is likewise inversely proportional to the output span.

Temp. coefficient: ± 0.015 %/°C (± 0.008 %/°F) of I/O range at -5 to +55°C [23 to 131°F]

Response time: 0.5 sec. + one pulse cycle or sampling time, whichever is larger (0 – 90 %)

Line voltage effect: ± 0.1 % over voltage range

Insulation resistance: ≥ 100 M Ω with 500 V DC

Dielectric strength: 1500 V AC @1 minute (input to output to power to ground)

CALCULATION EXAMPLES OF OVERALL ACCURACY

[Example] Open collector input, 0 – 50 kHz; 1 – 5 V output.

Selected freq. range (100 kHz) \div Input span (50 kHz) \times

Accuracy (0.03 %)= 0.06 % (Input accuracy)

Selected output range (20 V) \div Output span (4 V) \times

Accuracy (0.03 %)= 0.15 % (Output accuracy)

Overall accuracy = 0.06 + 0.15 = ± 0.21 %

STANDARDS & APPROVALS
EU conformity:

EMC Directive

EMI EN 61000-6-4

EMS EN 61000-6-2

Low Voltage Directive

EN 61010-1

Installation Category II

Pollution Degree 2

Input or output to power: Reinforced insulation (300 V)

Input to output: Basic insulation (300 V)

RoHS Directive

EN 50581

Approval:

UL/C-UL general safety requirements

(UL 61010-1, CAN/CSA-C22.2 No.1010-1)

EXTERNAL VIEW

■ FRONT VIEW

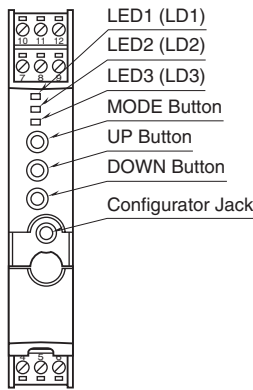

■ SIDE VIEW

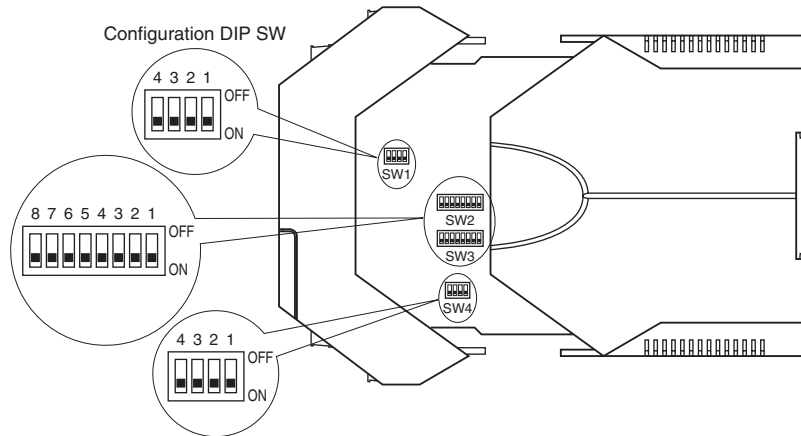

The DIP switch setting is required to select output types before setting a precise output range using the PC configurator software.

For detailed information on the configuration and calibration, refer to the instruction manual.

ADJUSTING DETECTING LEVEL

A specific sensitivity scale is applied according to the pulse amplitude by setting up the DIP switch and PC Configurator Software (model: M3CFG). The scaled input voltage is then compared to the detecting level at -2.00 through +4.00 V. For open collector input, be sure to adjust the voltage to following values if it has been changed for other input types.

Detecting level:

- 0.6 V (4 V excitation)
- 2 V (8 V / 12 V excitation)

With DC coupling, the scaled maximum input voltage level must be higher than and the scaled minimum input voltage level must be lower than the detecting level so that the pulse state is accurately detected.

Table 1

PULSE AMPLITUDE	MAX. VOLTAGE AT INPUT TERMINALS	SENSITIVITY SCALE
50 – 100V p-p	100V *1	1/20
25 – 50V p-p	50V *2	1/10
10 – 25V p-p	25V	1/5
5 – 10V p-p	10V	1/2
1 – 5V p-p	5V	1
0.5 – 1V p-p	1V	5
0.1 – 0.5V p-p *3	0.5V	10
Open collector Mechanical contact 2-wire current pulse	----	1

*1. 30V rms, 42.4V peak or 60V DC for UL approval
 *2. 30V rms, 42.4V peak or 50V DC for UL approval
 *3. Input frequency ≤50 kHz

Choose the noise filter type appropriate for the selected frequency range to ensure the described accuracy. Time constant is set to 50 msec. with the 'large' noise filter setting and to 10 msec. with the 'small' noise filter setting.

Table 2

FREQUENCY RANGE	NOISE FILTER
0 – 10 Hz	Small
0 – 100 Hz	Small
0 – 1 kHz	Small
0 – 10 kHz	None
0 – 200 kHz	None

EXTERNAL DIMENSIONS & TERMINAL ASSIGNMENTS unit: mm (inch)

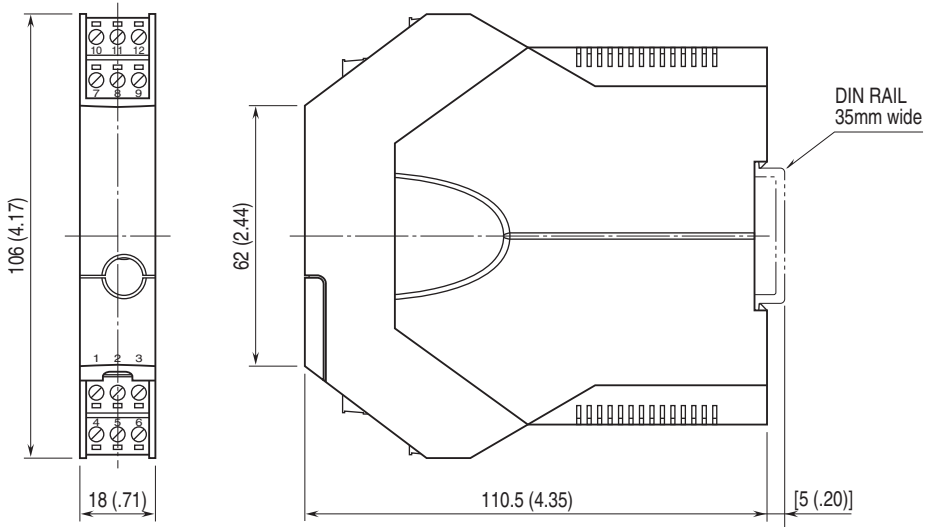

• When mounting, no extra space is needed between units.

SCHEMATIC CIRCUITRY & CONNECTION DIAGRAM

■ DC POWERED TYPE

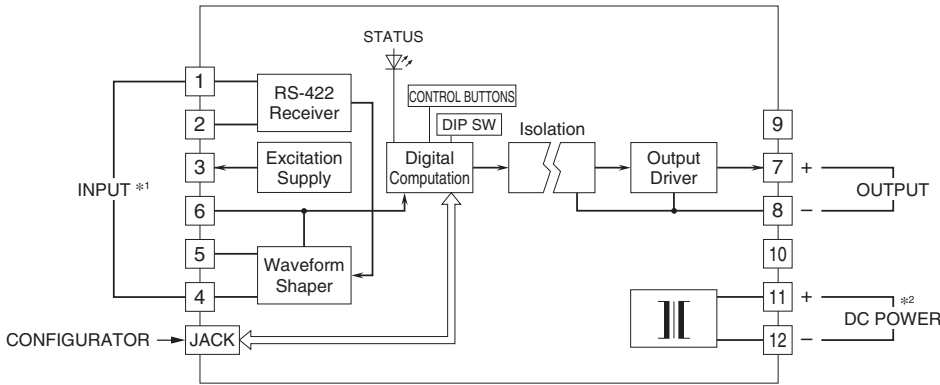

■ AC POWERED TYPE

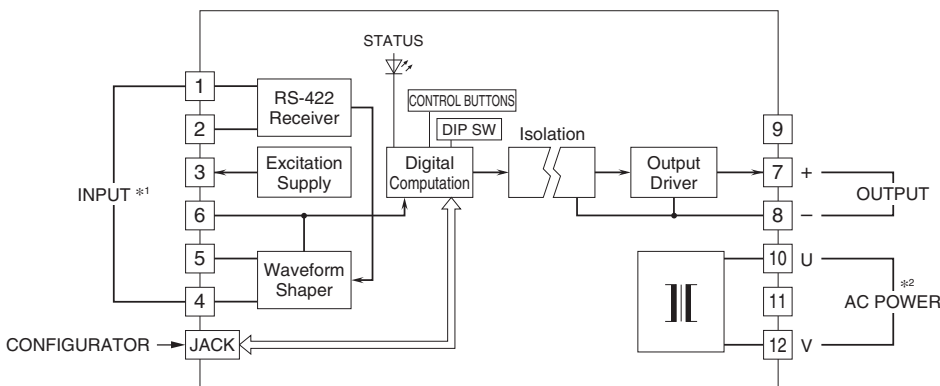

*2. Be aware that the AC power and DC power connect to different terminals.

*1. Input Connection Examples

■ Open Collector

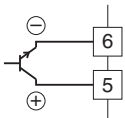

■ Voltage Pulse

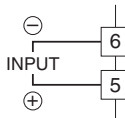

■ Two-wire Current Pulse

• Built-in Excitation

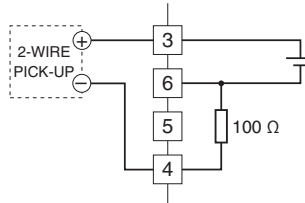

■ Excitation Supply

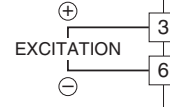

■ Mechanical Contact

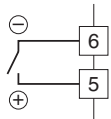

■ RS-422 Line Driver Pulse

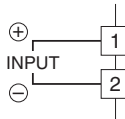

• External DC Supply

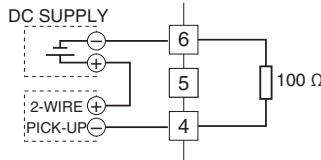

Specifications are subject to change without notice.