

Space-saving Two-wire Signal Conditioners B3-UNIT

2-WIRE UNIVERSAL TEMPERATURE TRANSMITTER

(HART communication, intrinsically safe)

Functions & Features

- Universal input: mV, V, T/C, RTD, resistance, potentiometer and DC voltage
- High accuracy
- HART communication
- Intrinsically safe approval
- Programming via hand-held communicator or via PC
- A wide variety of T/C and RTD types
- User's temperature table can be used
- Self diagnostics
- Input-output isolated

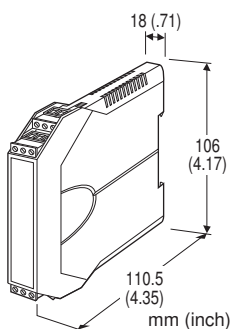

MODEL: B3HU-[1]/A

ORDERING INFORMATION

- Code number: B3HU-[1]/A
- Specify a code from below for [1]. (e.g. B3HU-0/A)
- Use Ordering Information Sheet (No. ESU-7502). Factory standard setting will be used if not otherwise specified.
- Specify the country in which the product is to be used with the Safety Approval code 2.

[1] SAFETY APPROVAL

- 0: None
- 1: FM intrinsically safe
- 2: CENELEC intrinsic safety (ATEX)

OPTIONS

CJC Sensor

/A: External Sensor (must be specified)

RELATED PRODUCTS

- USB interface Bell202 modem (model: COP-HU)
Usable in 'non-hazardous' area only.
- Hand-held communicator
(Consult HART Communication Foundation (HCF) web site: www.hartcomm.org.)
- AMS (version 6.0 or higher)
- Simatic PDM (version 6.0 or higher)
- PC configurator software (model: B3HUCFG)
Downloadable at M-System's web site.

GENERAL SPECIFICATIONS

- Construction:** Small-sized front terminal structure
- Connection:** Euro type connector terminal
(Applicable wire size: 0.2 - 2.5 mm², (pin terminals: 0.2 - 1.5 mm²) stripped length 8 mm)
- Housing material:** Flame-resistant resin (gray)
- Isolation:** Input to output
- Burnout (except DC voltage input):** Upscale, downscale or no burnout selectable (standard: upscale);
Also detects wire breakdown and overrange input exceeding the electrical design limit for DC voltage input.
- Cold junction compensation (T/C):** CJC sensor (included) to be attached to the input terminals
- User-configurable items:**
 - Input sensor type
 - Number of wires (RTD & resistance)
 - Input range
 - Inverted output
 - Burnout
 - Damping time (via HART only, standard: 0)
 - Sensor calibration (via HART only)
 - Output calibration
 - Special linearization data (via HART only)
 - HART communication mode

HART COMMUNICATION

- Protocol:** HART communication protocol
- HART address range:** 0 - 15 (factory set to 0)
- Transmission speed:** 1200 bps
- Digital current:** Approx. 1 mA_{p-p} when communicating
- Character format:** 1 Start Bit, 8 Data Bits, 1 Odd Parity Bit, 1 Stop Bit
- Distance:** 1.5 km (0.9 miles)
- HART communication mode:** Master-Slave Mode and Burst Mode (factory set to Master-Slave)
- HART network mode:** Point-to-Point Mode and Multi-drop Mode; automatically set to Multi-drop Mode when the address is set to other than 0.

Fuji Electric France S.A.S.

46, Rue Georges Besse - Z I du Brézet - 63 039 Clermont-Ferrand cedex 2 FRANCE
 France : Tél. 04 73 98 26 98 - Fax 04 73 98 26 99 - International : Tél. (33) 4 7398 2698 - Fax. (33) 4 7398 2699
 E-mail : sales.dpt@fujielectric.fr – WEB : www.fujielectric.fr

INPUT SPECIFICATIONS

The input is factory set for use with K thermocouple, 0 to 100°C.

See Table 1 for the available input type, the minimum span and the maximum range.

■ DC mV & V

Input resistance: $\geq 1 \text{ M}\Omega$

■ Thermocouple

Input resistance: $\geq 1 \text{ M}\Omega$

Burnout sensing: 130 nA $\pm 10 \%$

■ RTD (2-wire, 3-wire or 4-wire)

Excitation: 0.2 mA $\pm 10 \%$

Allowable leadwire resistance: Max. 20 Ω per wire

■ Resistance (2-wire, 3-wire or 4-wire)

Excitation: 0.2 mA $\pm 10 \%$

Allowable leadwire resistance: Max. 20 Ω per wire

■ Potentiometer

Excitation: 0.2 mA $\pm 10 \%$

Allowable leadwire resistance: Max. 20 Ω per wire

OUTPUT SPECIFICATIONS

Output range: 4 - 20 mA DC

Operational range: 3.8 - 21.6 mA

Load resistance vs. supply voltage:

Load Resistance (Ω) = (Supply Voltage (V) - 12 (V))
 $\div 0.024$ (A) (including leadwire resistance)

INSTALLATION

Supply voltage

- 12 - 42 V DC (non-approved)
- 12 - 28 V DC (approved)

Operating temperature: -40 to +85°C (-40 to +185°F)

(See Safety Parameters for use in a hazardous location.)

Operating humidity: 0 to 95 %RH (non-condensing)

Mounting: DIN rail

Weight: 80 g (2.8 oz)

PERFORMANCE

Cold junction compensation error: $\pm 0.5^\circ\text{C}$ or $\pm 0.9^\circ\text{F}$

Temp. coefficient: $\pm 0.015 \%/^\circ\text{C}$ ($\pm 0.008 \%/^\circ\text{F}$) of max. span at -5 to +55°C [23 to 131°F]

Start-up time: Approx. 8 sec.

Accuracy: See Table 1 and 'Explanations of Terms.'

Response time: ≤ 2 sec. (0 - 90 %) with damping time set to 0 and when not communicating via HART.

Supply voltage effect: $\pm 0.003 \%$ \times [Output Span] / 1 V

Insulation resistance: $\geq 100 \text{ M}\Omega$ with 500 V DC

Dielectric strength: 1500 V AC @1 minute

(input to output to ground)

EXPLANATIONS OF TERMS

■ ACCURACY

This transmitter's accuracy is theoretically defined as the addition of A/D and D/A conversion errors:

$$\text{Accuracy} = \text{A/D Conversion Error} + \text{D/A Conversion Error}$$

The A/D conversion error means that measured as HART signal which is A/D converted from the analog input signal. The D/A conversion error of this transmitter is relatively very small so that it does not really affect the unit's overall performance.

The "Accuracies" given in Table 1 therefore equals the A/D conversion error.

The temperature drift (coefficient) or the cold junction compensation error is not included in the "Accuracy."

■ CALCULATION EXAMPLES OF OVERALL ACCURACY IN %

• DC Voltage

1) 0 - 200 mV

Absolute value accuracy (Table 1): 40 μV

$$40 \mu\text{V} \div 200000 \mu\text{V} \times 100 = 0.02 \% < 0.1 \%$$

➡ Overall accuracy = $\pm 0.1\%$ of span

2) 0 - 4 mV

Absolute value accuracy (Table 1): 10 μV

$$10 \mu\text{V} \div 4000 \mu\text{V} \times 100 = 0.25 \% > 0.1 \%$$

➡ Overall accuracy = $\pm 0.25 \%$ of span

• Thermocouple

1) K thermocouple, 0 - 1000°C

Absolute value accuracy (Table 1): 0.25°C

$$0.1\% \times 1000^\circ\text{C} = 1^\circ\text{C} > 0.25^\circ\text{C}$$

CJC error (0.5°C) added: 1 + 0.5 = 1.5°C

$$1.5^\circ\text{C} \div 1000^\circ\text{C} \times 100 = 0.15 \%$$

➡ Overall accuracy including CJC error = $\pm 0.15 \%$ of span

2) K thermocouple, 50 - 150°C

Absolute value accuracy (Table 1): 0.25°C

$$0.1 \% \times (150 - 50)^\circ\text{C} = 0.1^\circ\text{C} < 0.25^\circ\text{C}$$

CJC error (0.5°C) added: 0.25 + 0.5 = 0.75°C

$$0.75^\circ\text{C} \div (150 - 50)^\circ\text{C} \times 100 = 0.75 \%$$

➡ Overall accuracy including CJC error = $\pm 0.75 \%$ of span

• RTD

1) Pt 100, -200 - 800°C

Absolute value accuracy (Table 1): 0.15°C

$$0.15^\circ\text{C} \div (800 - -200)^\circ\text{C} \times 100 = 0.015 \% < 0.1 \%$$

➡ Overall accuracy = $\pm 0.1 \%$ of span

2) Pt 100, 0 - 100°C

Absolute value accuracy (Table 1): 0.15°C

$$0.15^\circ\text{C} \div 100^\circ\text{C} \times 100 = 0.15 \% > 0.1 \%$$

➡ Overall accuracy = $\pm 0.15 \%$ of span

STANDARDS & APPROVALS**EU conformity:**

ATEX Directive

Ex ia EN 50020

EMC Directive

EMI EN 61000-6-4

EMS EN 61000-6-2

RoHS Directive

EN 50581

Safety approval:

FM: Intrinsically safe

Class I, Div. 1, Groups A, B, C and D

Class I, Zone 0, AEx ia IIC

T4 and T5

(Class 3610)

CENELEC: Intrinsic safety (ATEX)

⊕ II 1G, Ex ia IIC; T4 and T5

(EN 50020)

SAFETY PARAMETERS**Operating temperature****For CENELEC (ATEX) / FM:**

T4: -40 to +80°C

T5: -40 to +55°C

Ex-data:

• Output circuit

Ui (Vmax): 30 V DC

Ii (Imax): 96 mA DC

Pi (Pmax): 0.72 W

Ci: 1 nF

Li: 0 mH

• Sensor circuit

Uo (Voc): 6.4 V DC

Io (Isc): 30 mA DC

Po: 48 mW

Co (Ca): 20 µF

Lo (La): 10 mH

INPUT TYPE, RANGE & ACCURACY
■ INPUT TYPE, RANGE & ACCURACY

INPUT TYPE	MIN. SPAN	MAXIMUM RANGE		ACCURACY				
DC mV & V	4 mV	-50 to +1000 mV		±0.1 % or ±10μV, whichever is greater (F.S. input ≤ 50 mV) ±0.1 % or ±40μV, whichever is greater (F.S. input ≤ 200 mV) ±0.1 % or ±60μV, whichever is greater (F.S. input ≤ 500 mV) ±0.1 % or ±80μV, whichever is greater (F.S. input > 500 mV)				
Potentiometer	2 %	Total resistance 150 to 4000Ω		±0.1 %				
Resistance	10Ω	0 to 4000Ω		±0.1 % or ±0.1Ω, whichever is greater.*2				
THERMOCOUPLE	°C				°F			
	MIN. SPAN	MAXIMUM RANGE	CONFORMANCE RANG	ACCURACY *1	MIN. SPAN	MAXIMUM RANGE	CONFORMANCE RANG	ACCURACY *1
(PR)	20	0 to 1760	0 to 1760	±1.00	36	32 to 3200	32 to 3200	±1.80
K (CA)	20	-270 to +1370	-150 to +1370	±0.25	36	-454 to +2498	-238 to +2498	±0.45
E (CRC)	20	-270 to +1000	-170 to +1000	±0.20	36	-454 to +1832	-274 to +1832	±0.36
J (IC)	20	-210 to +1200	-180 to +1200	±0.25	36	+346 to +2192	-292 to +2192	±0.45
T (CC)	20	-270 to +400	-170 to +400	±0.25	36	-454 to +752	-274 to +752	±0.45
B (RH)	20	100 to 1820	400 to 1760	±0.75	36	212 to 3308	752 to 3200	±1.35
R	20	-50 to +1760	200 to 1760	±0.50	36	-58 to +3200	392 to 3200	±0.90
S	20	-50 to +1760	0 to 1760	±0.50	36	-58 to +3200	32 to 3200	±0.90
C (WRe 5-26)	20	0 to 2315	0 to 2315	±0.25	36	32 to 4199	32 to 4199	±0.45
N	20	-270 to +1300	-130 to +1300	±0.30	36	-454 to +2372	-202 to +2372	±0.54
U	20	-200 to +600	-200 to +600	±0.20	36	-328 to +1112	-328 to +1112	±0.36
L	20	-200 to +900	-200 to +900	±0.25	36	-328 to +1652	-328 to +1652	±0.45
P (Platinel II)	20	0 to 1395	0 to 1395	±0.25	36	32 to 2543	32 to 2543	±0.45
RTD	°C				°F			
	MIN. SPAN	MAXIMUM RANGE		ACCURACY *2	MIN. SPAN	MAXIMUM RANGE		ACCURACY *2
Pt 100 (JIS '97, IEC)	20	-200 to +850		±0.15	36	-328 to +1562		±0.27
Pt 200	20	-200 to +850		±0.15	36	-328 to +1562		±0.27
Pt 300	20	-200 to +850		±0.15	36	-328 to +1562		±0.27
Pt 400	20	-200 to +850		±0.15	36	-328 to +1562		±0.27
Pt 500	20	-200 to +850		±0.15	36	-328 to +1562		±0.27
Pt 1000	20	-200 to +850		±0.15	36	-328 to +1562		±0.27
Pt 50 Ω (JIS '81)	20	-200 to +649		±0.15	36	-328 to +1200		±0.27
JPt 100 (JIS '89)	20	-200 to +510		±0.15	36	-328 to +950		±0.27
Ni 100	20	-80 to +260		±0.15	36	-112 to +500		±0.27
Ni 120	20	-80 to +260		±0.15	36	-112 to +500		±0.27
Ni 508.4 Ω	20	-50 to +200		±0.15	36	-58 to +392		±0.27
Ni-Fe 604	20	-200 to +200		±0.15	36	-328 to +392		±0.27
CU10 @ 25°C	20	-50 to +250		±0.50	36	-58 to +482		±0.90

*1. [Accuracy or ±0.1% of span, whichever is greater] + Cold Junction Compensation Error.

*2. Or ±0.1% of span, whichever is greater.

(For 2- or 3-wire resistance or RTD, the value is valid by the sensor calibration after the wiring is done.)

EXTERNAL DIMENSIONS & TERMINAL ASSIGNMENTS unit: mm (inch)

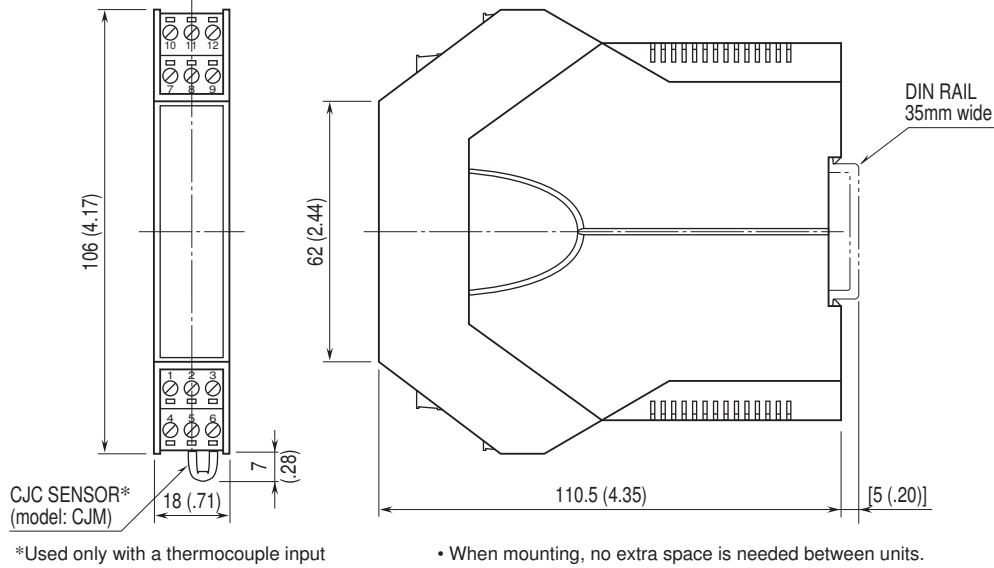

SCHEMATIC CIRCUITRY & CONNECTION DIAGRAM

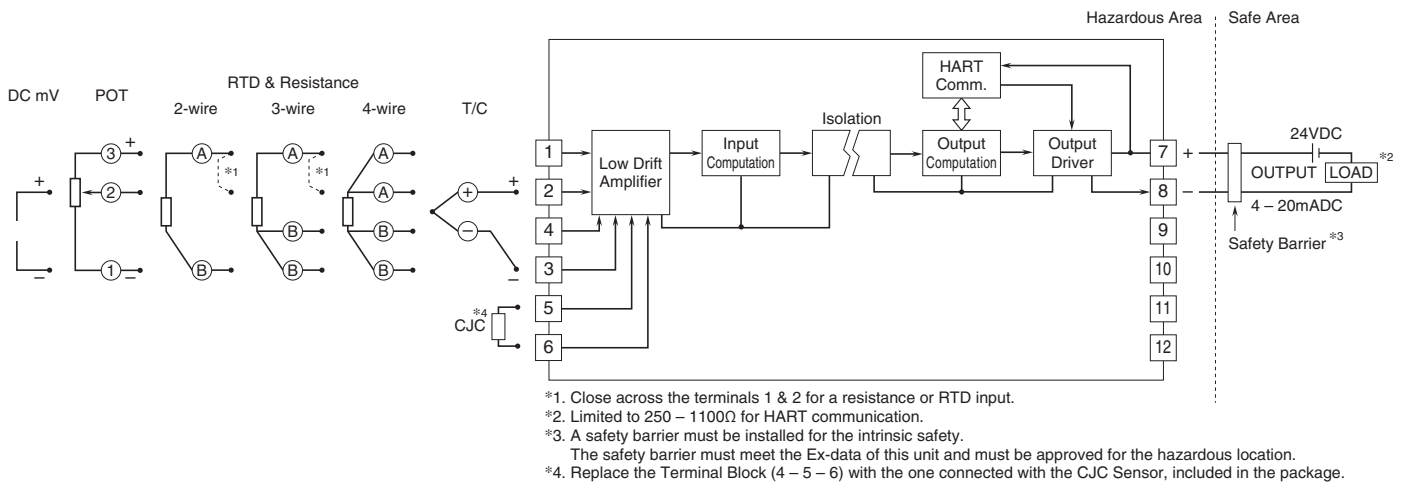

 Specifications are subject to change without notice.