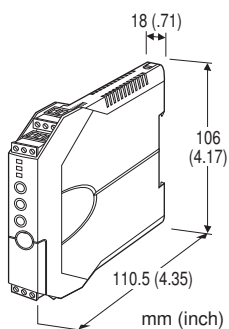

Space-saving Signal Conditioners M3-UNIT Series
UNIVERSAL TRANSMITTER

(field- and PC-configurable)

Functions & Features

- Universal input: mV, V, mA, T/C, RTD, resistance and potentiometer
- Easy 'One-Step Cal' calibration using the front three control buttons without needing a PC; PC software is also usable.
- I/O type and ranges are configurable
- Front control button function can be locked

MODEL: M3LU2-[1]/[2][3]
ORDERING INFORMATION

- Code number: M3LU2-[1]/[2][3]
- Specify a code from below for each [1] through [3].
(e.g. M3LU2-R4/A/Q)
- Specify the specification for option code /Q
(e.g. /C01)
 - Use Ordering Information Sheet (No. ESU-2653).
Factory setting (indicated below) will be used if not otherwise specified.
Input: 4 - 20 mA
Output: 4 - 20 mA

INPUT - Field-selectable
DC Current & Voltage
Current: 0 - 20 mA DC

Millivolt: -1000 - +1000 mV DC

Voltage: -10 - +10 V DC

Thermocouple

(PR), K, E, J, T, B, R, S, C (WRe 5-26),
N, U, L, P (Platinel II)

RTD

Pt 100, Pt 200, Pt 300, Pt 400, Pt 500, Pt 1000,
Ni 100, Ni 120, Ni 508.4Ω, Ni-Fe 604,
Cu 10 @25°C, Pt 50Ω, JPt 100

Potentiometer

Total resistance 80 - 4000 Ω

Resistance

0 - 4000 Ω

OUTPUT - Field-selectable
Current

0 - 20 mA DC

Voltage

-2.5 - +2.5 V DC

-10 - +10 V DC

[1] POWER INPUT
AC Power
M2: 100 - 240 V AC (Operational voltage range 85 - 264 V,
47 - 66 Hz)

DC Power
R4: 10 - 32 V DC

(Operational voltage range 9 - 36 V, ripple 10 %p-p max.)

[2] CONFIGURATION OPTIONS
A: PC and field configurable

B: Field configurable

[3] OPTIONS
blank: none

/Q: With options (specify the specification)

SPECIFICATIONS OF OPTION: Q
COATING (For the detail, refer to M-System's web site.)
/C01: Silicone coating

/C02: Polyurethane coating

/C03: Rubber coating

RELATED PRODUCTS

- PC configurator software (model: M3CFG)

Downloadable at M-System's web site.

A dedicated cable is required to connect the module to the PC. Please refer to the internet software download site or the users manual for the PC configurator for applicable cable types.

GENERAL SPECIFICATIONS
Construction: Stand-alone; terminal access at the front

Connection: Euro type connector terminal

Housing material: Flame-resistant resin (gray)

Isolation: Input to output to power

Overrange output: -15 to +115 %

(Negative current output is not available.)

Zero adjustment: -15 to +15 % (front)

Span adjustment: 85 to 115 % (front)

Burnout (other than current or voltage (V) input): Upscale, downscale or no burnout selectable; Also detects wire breakdown and overrange input exceeding the electrical design limit for DC input.

Linearization (thermocouple & RTD input): Standard

Cold junction compensation (T/C): CJC sensor (included) to be attached to the input terminals

Status indicator LED: Tri-color (green/amber/red) LED; Blinking patterns indicate operation status of the transmitter.

Configuration:

PC Configurator: (Model: M3LUCFG) via Windows PC connected to the front jack.

Programmable features include:

- I/O type and range
 - Zero and span adjustments
 - Burnout action
 - User's linearization table setting
 - User's T/C, RTD table setting
- (Refer to the instruction manual)

'One-Step Cal' calibration: With I/O type and the full-scale range configured via the internal DIP switches, precise 0 % and 100 % ranges are calibrated via the front control buttons with a help of LED. Also I/O calibration and fine adjustment are available with a PC.

Configurator connection: 2.5 dia. miniature jack; RS-232-C level

INPUT SPECIFICATIONS

Input type and range are configurable. See Table 1 for the available input type, the minimum span, the maximum range, the conformance range (T/C) and the input conversion accuracy.

For type and range configuration, refer to the instruction manual.

■ **DC current:** 50 Ω resistor incorporated

■ **DC mV & voltage**

Input resistance: ≥ 1 MΩ

■ **Thermocouple**

Input resistance: ≥ 1 MΩ

Burnout sensing: ≤ 4 μA

■ **RTD (2-wire, 3-wire or 4-wire)**

Excitation: ≤ 0.3 mA

Allowable leadwire resistance: 20 Ω per wire

■ **Resistance (2-wire, 3-wire or 4-wire)**

Excitation: ≤ 0.3 mA

Allowable leadwire resistance: 20 Ω per wire

■ **Potentiometer**

Excitation: ≤ 0.3 mA

Allowable leadwire resistance: 20 Ω per wire

OUTPUT SPECIFICATIONS

Output type and range are as follows.

For type and range configuration, refer to the instruction manual.

■ **DC Current**

Maximum range: 0 – 20 mA DC

Minimum span: 1 mA

Conformance range: 0 – 23 mA DC

Offset: Lower range can be any specific value within the output range provided that the minimum span is maintained.

Load resistance: Output drive 15 V max. at 20 mA
(Range: Load resistance) 0 – 20 mA : ≤ 750 Ω

■ **DC Voltage**

Narrow spans

Maximum range: -2.5 – +2.5 V DC

Minimum span: 250 mV

Conformance range: -3 – +3 V DC

Wide spans

Maximum range: -10 – +10 V DC

Minimum span: 1 V

Conformance range: -11.5 – +11.5 V DC

Offset: Lower range can be any specific value within the output range provided that the minimum span is maintained.

Load resistance: Output drive 10 mA max.; 5 mA for negative output
(Range: Load resistance)

0 – 10 V : ≥ 1 kΩ

-10 – 0 V : ≥ 2 kΩ

0 – 2.5 V : ≥ 250 Ω

-2.5 – 0 V : ≥ 500 Ω

INSTALLATION

Power Consumption

• **AC:**

Approx. 4 VA at 100 V

Approx. 5 VA at 200 V

Approx. 6 VA at 264 V

• **DC:** Approx. 3 W

Operating temperature: -25 to +60°C (-13 to +140°F)

Operating humidity: 30 to 95 %RH (non-condensing)

Mounting: DIN rail

Weight: 100 g (3.53 oz)

PERFORMANCE

Accuracy: See Table 1.

Cold junction compensation error:

±1.0°C at 0 – 50°C (±1.8°F at 32 – 122°F)

Temp. coefficient:

± 0.015 %/°C [± 0.008 %/°F] at -5 to +55°C [23 to 131°F] of max. range

± 0.03 %/°C [± 0.016 %/°F] for the following conditions:

- DC, T/C input spans ≤ 10 mV
- RTD, potentiometer, resistance spans ≤ 80 Ω
- in an ambient exceeding 55°C [131°F] or below -5°C [23°F]

Response time: ≤ 0.2 sec. (0 - 90%, DC input)
(With the Option A, the Sync Filter set to the fastest frequency on the PC Configurator Software. Default is set to have 0.5-second response.)

Burnout response: ≤ 10 sec.

Line voltage effect: ± 0.1 % over voltage range

Insulation resistance: ≥ 100 M Ω with 500 V DC

Dielectric strength: 2000 V AC @1 minute (input to output to power to ground)

EMI EN 61000-6-4

EMS EN 61000-6-2

Low Voltage Directive

EN 61010-1

Installation Category II

Pollution Degree 2

Input or output to power: Reinforced insulation (300 V)

Input to output: Basic insulation (300 V)

RoHS Directive

EN 50581

CALCULATION EXAMPLES OF OVERALL ACCURACY

• DC Voltage

1) 0 - 200 mV

Absolute value accuracy (Table 1): 40 μ V

$40 \mu\text{V} \div 200000 \mu\text{V} \times 100 = 0.02\% < 0.1\%$

➤ Overall accuracy = $\pm 0.1\%$ of span

2) 0 - 4 mV

Absolute value accuracy (Table 1): 10 μ V

$10 \mu\text{V} \div 4000 \mu\text{V} \times 100 = 0.25\% > 0.1\%$

➤ Overall accuracy = $\pm 0.25\%$ of span

• Thermocouple

1) K thermocouple, -150 - +1370°C

Absolute value accuracy (Table 1): 0.25°C

CJC error (1.0°C) added: 1.25°C

$1.25^\circ\text{C} \div 1520^\circ\text{C} \times 100 = 0.082\% < 0.1\%$

➤ Overall accuracy including CJC error = $\pm 0.1\%$ of span

2) K thermocouple, 50 - 150°C

Absolute value accuracy (Table 1): 0.25°C

CJC error (1.0°C) added: 1.25°C

$1.25^\circ\text{C} \div (150 - 50)^\circ\text{C} \times 100 = 1.25\% > 0.1\%$

➤ Overall accuracy including CJC error = $\pm 1.25\%$ of span

• RTD

1) Pt 100, -200 - 800°C

Absolute value accuracy (Table 1): 0.15°C

$0.15^\circ\text{C} \div (800 - -200)^\circ\text{C} \times 100 = 0.015\% < 0.1\%$

➤ Overall accuracy = $\pm 0.1\%$ of span

2) Pt 100, 0 - 100°C

Absolute value accuracy (Table 1): 0.15°C

$0.15^\circ\text{C} \div 100^\circ\text{C} \times 100 = 0.15\% > 0.1\%$

➤ Overall accuracy = $\pm 0.15\%$ of span

STANDARDS & APPROVALS

EU conformity:

EMC Directive

EXTERNAL VIEW

■ FRONT VIEW

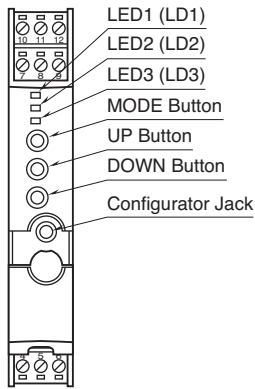

■ SIDE VIEW

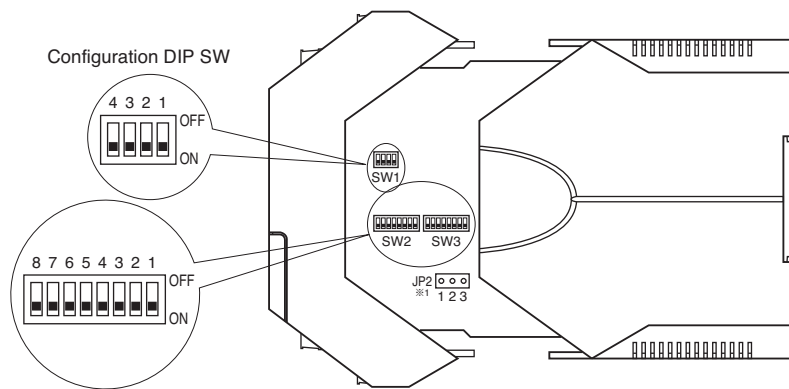

*For Voltage Input (V) range, switch the JP2 jumper to the 2 – 3 position.

**Normal Position
(other than DC Voltage [V] range)**

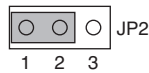

DC Voltage [V] Range Position

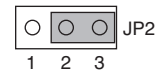

The DIP switch setting is required to select output types before setting a precise output range using the PC configurator software.

For detailed information on the configuration and calibration, refer to the instruction manual.

INPUT TYPE, RANGE & ACCURACY
■ INPUT TYPE, RANGE & ACCURACY
TABLE 12

INPUT TYPE	MIN. SPAN	MAXIMUM RANGE			ACCURACY*1			
DC Current	1mA	0 to 20mA			±0.1%			
DC Millivolt	4mA	-1000 to +1000mV			±10μV at F.S. input ≤ 50mV ±40μV at F.S. input ≤ 200mV ±60μV at F.S. input ≤ 500mV ±80μV at F.S. input > 500mV			
DC Voltage	1V	-10 to +10V			±0.1%			
Potentiometer	2%	total resistance 80 to 4000Ω			±0.1Ω			
Resistance	10Ω	0 to 4000Ω			±0.1Ω			
Thermocouple	°C				°F			
	MIN. SPAN	MAXIMUM RANGE	CONFORMANCE RANGE	ACCURACY*1	MIN. SPAN	MAXIMUM RANGE	CONFORMANCE RANGE	ACCURACY*1
(PR)	20	0 to 1760	0 to 1760	±1.00	36	32 to 3200	32 to 3200	±1.80
K (CA)	20	-270 to +1370	-150 to +1370	±0.25	36	-454 to +2498	-238 to +2498	±0.45
E (CRC)	20	-270 to +1000	-170 to +1000	±0.20	36	-454 to +1832	-274 to +1832	±0.36
J (IC)	20	-210 to +1200	-180 to +1200	±0.25	36	-346 to +2192	-292 to +2192	±0.45
T (CC)	20	-270 to +400	-170 to +400	±0.25	36	-454 to +752	-274 to +752	±0.45
B (RH)	20	100 to 1820	400 to 1760	±0.75	36	212 to 3308	752 to 3200	±1.35
R	20	-50 to +1760	200 to 1760	±0.50	36	-58 to +3200	392 to 3200	±0.90
S	20	-50 to +1760	0 to 1760	±0.50	36	-58 to +3200	32 to 3200	±0.90
C (WRe 5-26)	20	0 to 2315	0 to 2315	±0.25	36	32 to 4199	32 to 4199	±0.45
N	20	-270 to +1300	-130 to +1300	±0.30	36	-454 to +2372	-202 to +2372	±0.54
U	20	-200 to +600	-200 to +600	±0.20	36	-328 to +1112	-328 to +1112	±0.36
L	20	-200 to +900	-200 to +900	±0.25	36	-328 to +1652	-328 to +1652	±0.45
P (Platinel II)	20	0 to 1395	0 to 1395	±0.25	36	32 to 2543	32 to 2543	±0.45
RTD	°C				°F			
	MIN.SPAN	MAXIMUM RANGE	ACCURACY*1		MIN.SPAN	MAXIMUM RANGE	ACCURACY*1	
Pt 100 (JIS '97, IEC)	20	-200 to +850	±0.15		36	-328 to +1562	±0.27	
Pt 200	20	-200 to +850	±0.15		36	-328 to +1562	±0.27	
Pt 300	20	-200 to +850	±0.15		36	-328 to +1562	±0.27	
Pt 400	20	-200 to +850	±0.15		36	-328 to +1562	±0.27	
Pt 500	20	-200 to +850	±0.15		36	-328 to +1562	±0.27	
Pt 1000	20	-200 to +850	±0.15		36	-328 to +1562	±0.27	
Pt 50Ω (JIS '81)	20	-200 to +649	±0.15		36	-328 to +1200	±0.27	
JPt 100 (JIS '89)	20	-200 to +510	±0.15		36	-328 to +950	±0.27	
Ni 100	20	-80 to +260	±0.15		36	-112 to +500	±0.27	
Ni 120	20	-80 to +260	±0.15		36	-112 to +500	±0.27	
Ni 508.4Ω	20	-50 to +200	±0.15		36	-58 to +392	±0.27	
Ni-Fe 604	20	-200 to +200	±0.15		36	-328 to +392	±0.27	
Cu 10 @25°C	20	-50 to +250	±0.50		36	-58 to +482	±0.90	

*1. DC, RTD, Resistance, Potentiometer input: Or ±0.1% of span, whichever is greater.

Thermocouple input: [Accuracy + Cold Junction Compensation Error 1.0°C (1.8°F)] or ±0.1% of span, whichever is greater.

For current output, overall accuracy degrades another 0.1% with spans ≤2mA.

EXTERNAL DIMENSIONS & TERMINAL ASSIGNMENTS unit: mm (inch)

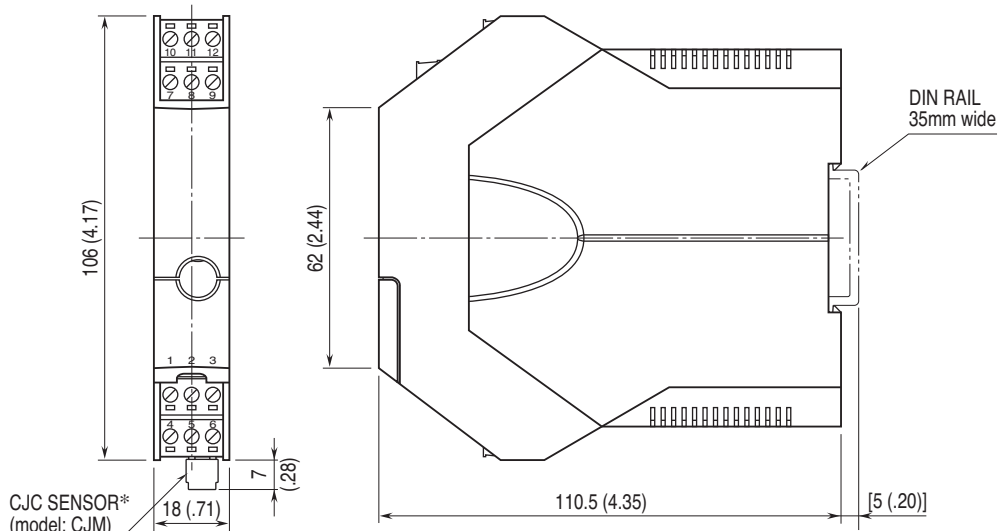

*Used only with a thermocouple input

• When mounting, no extra space is needed between units.

SCHEMATIC CIRCUITRY & CONNECTION DIAGRAM

■ DC POWERED TYPE

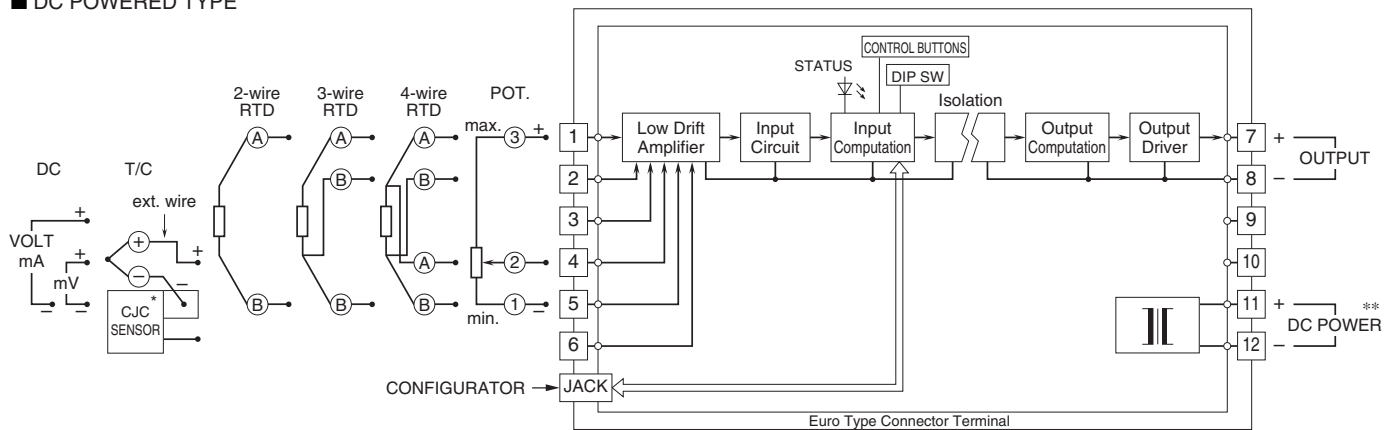

■ AC POWERED TYPE

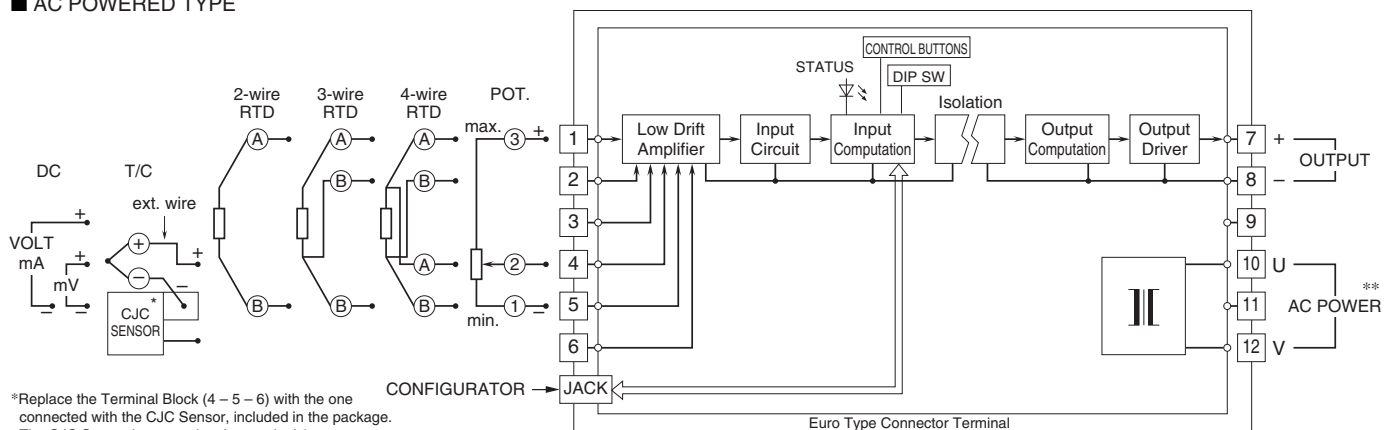

*Replace the Terminal Block (4 – 5 – 6) with the one connected with the CJC Sensor, included in the package. The CJC Sensor is secured to the terminal 6. Loosen only the terminal 4 – 5 and connect the T/C extension wires.

**Be aware that the AC power and DC power connect to different terminals.



Specifications are subject to change without notice.