

CONTENTS

BEFORE USE	2
POINTS OF CAUTION.....	2
PERFORMANCE	3
LIGHTNING SURGE PROTECTION	3
COMPONENT IDENTIFICATION	4
INSTALLATION	5
TERMINAL CONNECTIONS	6
MODBUS WIRING CONNECTION	8
SYSTEM CONFIGURATION EXAMPLES	9
MODBUS - BASICS	10
MODBUS - OPERATIONS	11
MODBUS - SETTING.....	13
MODBUS - MEASURED VARIABLES	26
OPERATION FLOWCHART	38
SETTING EXAMPLES	48
ERROR MESSAGES.....	50
MAINTENANCE.....	50

BEFORE USE

Thank you for choosing M-System. Before use, please check contents of the package you received as outlined below. If you have any problems or questions with the product, please contact M-System's Sales Office or representatives.

■ **PACKAGE INCLUDES:**

Multi power monitor.....(1)

■ **MODEL NO.**

Confirm Model No. marking on the product to be exactly what you ordered.

■ **OPERATING MANUAL**

This manual describes necessary points of caution when you use this product, including installation, connection, basic maintenance procedures, and detailed operations. The 53U is programmable either by using the front control buttons or the PC Configurator Software. For detailed information on the PC configuration, refer to the PMCFG users manual. The PMCFG PC Configurator Software is downloadable at M-System's web site.

<http://www.m-system.co.jp>

Availability of certain functions explained in this manual depends upon hardware options and firmware versions. Those limited ones are identified with the following markings.

PMCFG users manual.

Software and manuals are downloadable at M-System's web site.

MARKING	LIMITATION
AO	Analog output option
DO	Discrete output option
DI	Discrete input option
MO	Modbus interface option
1.01	Ver.1.01 or higher versions
2.00	Ver.2.00 or higher versions

<http://www.m-system.co.jp>

■ **INTENDED USE**

This equipment is a digital panel meter which measures simultaneously several variables of a heavy-current power system: current, voltage, active, reactive and apparent power, active and reactive energy, power factor, frequency, etc.

■ **SYMBOLS USED ON THE PRODUCT AND IN THIS MANUAL**

 This symbol on the product indicates that the operator must refer to an explanation in the user's manual in order to avoid the risk of injury or death of personnel or damage to the instrument.

 This symbol indicates double insulation.

! POINTS OF CAUTION

■ **CAUTION**

If Equipment is not used in a manner not specified by M-System, the protection provided by the equipment may be impaired.

■ **CONFORMITY WITH EC DIRECTIVES OR UL**

• This equipment is suitable for use in a Pollution Degree 2 environment and in Measurement Category III, Installation Category II, with the maximum operating voltage of 550V between signal input and output or power and 300V between output and power. Prior to installation, check that the insulation class of this unit satisfies the system requirements.

- Altitude up to 2000 meters
- The equipment must be mounted inside a panel.
- For safety, be sure to install a circuit breaker switch as part of the building installation that conforms to IEC 60947-1 and IEC 60947-3 near the 53U so as to be operated easily, and clearly indicate that the device is used to de-energize the 53U. The circuit breaker must be provided on both side of the line or must be "common trip" type.
- Insert a noise filter for the power source connected to the unit. Cosel Noise Filter Model NAC-06-472 or equivalent is recommended.

■ **POWER INPUT RATING & OPERATIONAL RANGE**

Locate the power input rating marked on the product and confirm its operational range as indicated below.

100 – 240V AC rating: 85 – 264V AC, 47 – 66 Hz, <8VA
 110 – 240V DC rating: 99 – 264V DC, <4W (UL approval is not available)

- For UL approved model, power input terminals are marked with L and N instead of U(+) and V(-).

■ **GENERAL PRECAUTION**

Before you remove or mount the unit, turn off the power supply and input signal for safety.

■ **ENVIRONMENT**

- Indoor use
- Do not install the unit where it is directly exposed to rain, water droplets or sunlight.
- When heavy dust or metal particles are present in the air, install the unit inside proper housing with sufficient ventilation.
- Do not install the unit where it is subjected to continuous vibration. Do not apply physical impact to the unit.
- Environmental temperature must be within -10 to +55°C (14 to 131°F) with relative humidity within 90% RH in order to ensure adequate life span and operation.
- Contrast of the LCD screen depends upon viewing angles. Choose the height and angle where it is the most legible.
- Do not apply physical impact to the front face.
- To ensure the designated ingress protection, insert the gasket as shown below before attaching the mounting brackets.

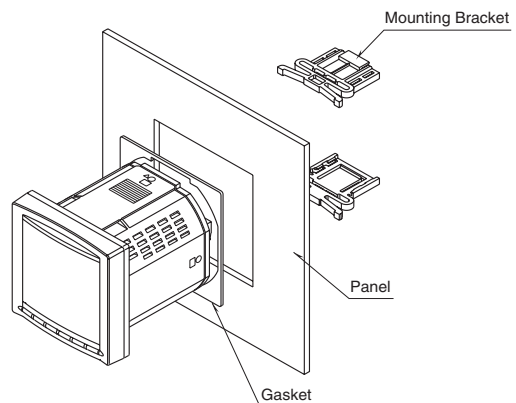

■ **WIRING**

- Wiring to the unit must be conducted by qualified service personnel.
- Do not install cables (power supply, input and output) close to noise sources (relay drive cable, high frequency line, etc.).
- Do not bind these cables together with those in which noises are present. Do not install them in the same duct.

■ **AND**

The unit is designed to function as soon as power is supplied, however, a warm up for 30 minutes is required for satisfying complete performance described in the data sheet.

PERFORMANCE

Accuracy (at 23°C ±10°C or 73.4°F ±18°F, 45 – 65 Hz)

Voltage: ±0.3% (±0.2% for Option /H)*

Current: ±0.3% (±0.2% for Option /H)*

Power: ±0.5%*

Power factor: ±0.5%

Frequency: ±0.1%*

Energy: ±1% (±0.5% for Option /H)

Harmonic contents: ±1%*

Analog output: Accuracy of assigned measurand or ±0.2%, whichever is greater.

Response time: ≤2 seconds (0 – 99%)

≤3 seconds for frequency and harmonic contents

*In percentage of the spans: 480V for voltage, 1A or 5A for current, 4155W (5A) or 831W (1A) for active power. The described accuracy levels are ensured at the input 1% or more for phase 2 current with 3-phase/3-wire unbalanced load, for neutral current with 3-phase/4-wire unbalanced load, and neutral current with 1-phase/3-wire.

■ INPUT

Frequency: 50 – 60 Hz

Voltage Input

Rated voltage:

Line-to-line (delta voltage): 480V

Line-neutral (phase voltage): 277V

(for single phase/2-wire and single phase/3-wire)

Consumption VA: ≤ $U_{LN}^2 / 300k\Omega$ / phase

Current Input

Rated current: 1A or 5A

Consumption VA: ≤ $I^2 \cdot 0.01\Omega$ / phase

Contact Input: 24V DC or 110V DC (input resistance 6kΩ)

Power input:

100 – 240V AC, 8VA max., 50 – 60 Hz

110 – 240V DC, 4W max. (UL approval is not available)

■ OUTPUT

Network Interface

Interface: Conforms to EIA RS-485

Protocol: Modbus RTU

DC Current Output: 4 – 20mA DC, load resistance: 270Ω
maximum

DC Voltage Output: 1 – 5V DC, load resistance: 5000Ω
minimum

Open Collector

Programmable for either alarm or energy count.

Max. rated load: 130V DC @50mA

Continuous rated load: 130V DC @30mA

■ **Measurement category:** CAT.III

■ **Power input installation category:** CAT.II

The definition of the measurement category

CAT.I: Circuits not directly connected to the main power supply

CAT.II: Circuits directly connected to low-voltage facility

CAT.III: Circuits in building facility

CAT.IV: Power sources for low-voltage facility

LIGHTNING SURGE PROTECTION

In order to protect the unit from lightning surges entering through signal and power supply cables, use of appropriate lightning surge protectors are recommended. Please contact M-System.

COMPONENT IDENTIFICATION

FRONT VIEW

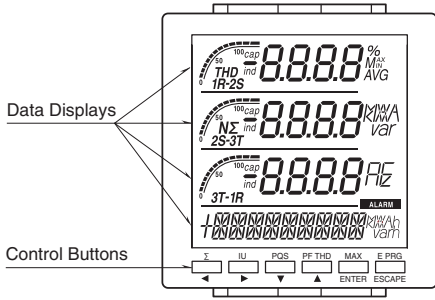

REAR VIEW

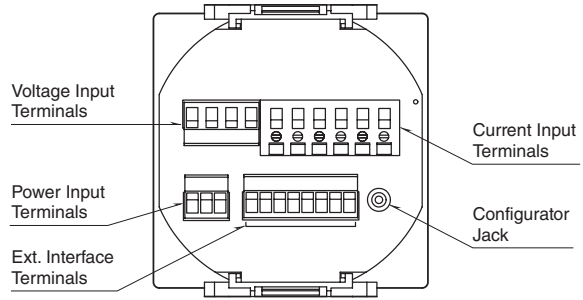

CONTROL BUTTON OPERATIONS

BUTTON OPERATION	FUNCTIONS	
	NORMAL MODE	SETTING MODE
Σ ◀	Indicates values	Go Left
IU ▶	Indicates Voltage or Current	Go Right
PQS ▼	Indicates Power	Go Down
PF THD ▲	Indicates Power Factor or THD	Go Up
MAX ENTER	Indicates totalized values (max., min., average/demand)	Selects menu; Enables setting changes
E PRG ESCAPE	Switches Energy readings	Cancels setting changes
Σ ◀ Hold down	Switches to My Default mode	----
IU ▶ Hold down	Switches to PC Configuration mode	----
E PRG ESCAPE Hold down	Switches to Setting mode	----
IU ▶ + PF THD ▲ Hold down	Indicates Harmonics by degrees	----
Σ ◀ + E PRG ESCAPE Hold down	Switches Energy reading units	----
PQS ▼ Hold down	Indicates the shortcut menu	----

HOW TO CHANGE VALUES (e.g. 5.000A to 150.0A)

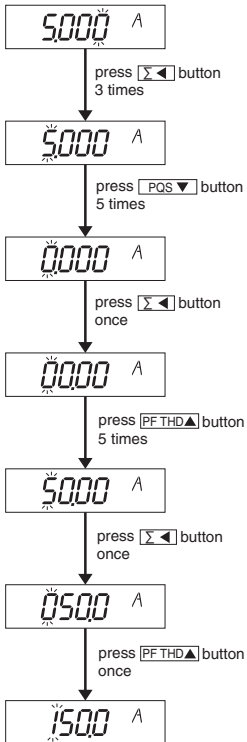

Press \square PQS ▼ \square PF THD ▲ to increase or decrease the value.
 Press \square Σ ◀ \square IU ▶ to move between digits.
 Pressing \square Σ ◀ at the leftmost digit shifts the value on display to the right by 1 digit.
 The decimal point and unit are also switched to appropriate ones.

INSTALLATION

EXTERNAL DIMENSIONS unit: mm (inch)

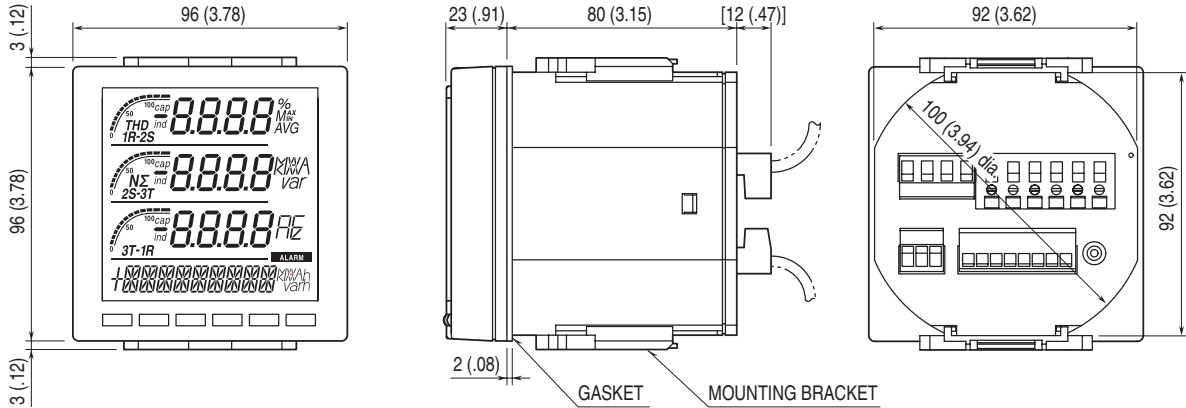

PANEL CUTOUT unit: mm (inch)

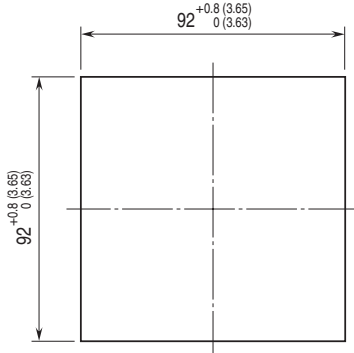

Panel thickness : 2 to 15 mm (0.08 to 0.59 inch)

WIRING

Current input

Applicable cable size: ≤ 2.4 mm dia., 0.5 to 3.5 mm²
Recommended core exposure length: 13 to 15 mm

Voltage input

Applicable cable size: ≤ 2.5 mm dia., 0.5 to 3.5 mm²
Recommended core exposure length: 7 to 8 mm

Output, power input

Applicable cable size: ≤ 2.4 mm dia., 0.5 to 2.5 mm²
Recommended core exposure length: 7 to 8 mm

CONNECTING TO POWER SOURCE

- Confirm the power input rating on the specification label.

	Rated voltage
AC Power	100 – 240 V AC
DC Power*1	110 – 240 V DC

- How to Connect the power supply cable:
 - Confirm that the power supply is turned off.
 - Pull and remove the terminal block marked U(+) and V(-)*2 from the 53U.
 - Loosen two (2) screws corresponding to U(+) and V(-)*2 at the terminal block.
 - Insert wires into the connection.
 - Fix them with the screw.
 - Replace the terminal block back into the 53U.

*1. UL approval is not available

*2. For UL approved model, L and N are marked.

TERMINAL CONNECTIONS

For UL approved model, L and N are marked instead of U(+) and V(-).

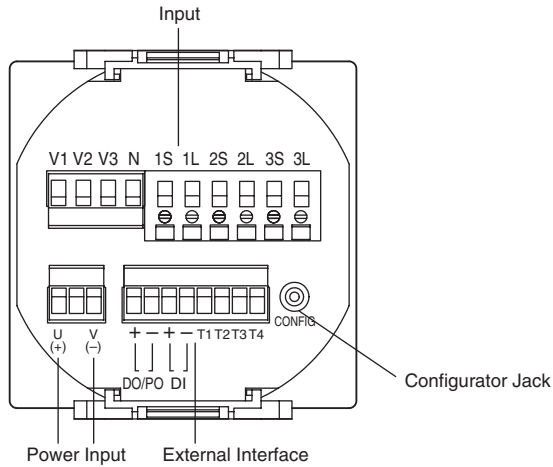

System / Application	Terminal
Single phase / 2-wire	
Three phase / 3-wire, unbalanced load	
Three phase / 4-wire, balanced load	
Three phase / 3-wire, balanced load	
Three phase / 4-wire, unbalanced load	
Single phase / 3-wire	

■ EXTERNAL INTERFACE CODE: 1

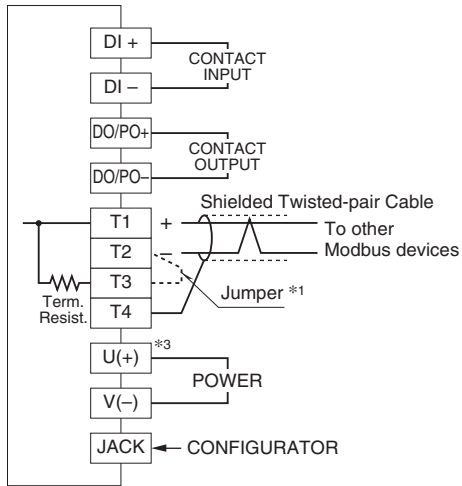

■ EXTERNAL INTERFACE CODE: 2, 3

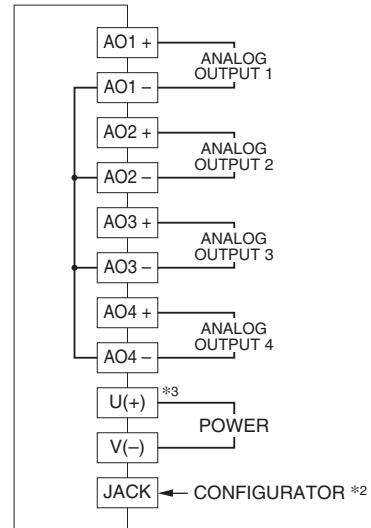

■ EXTERNAL INTERFACE CODE: 4, 5

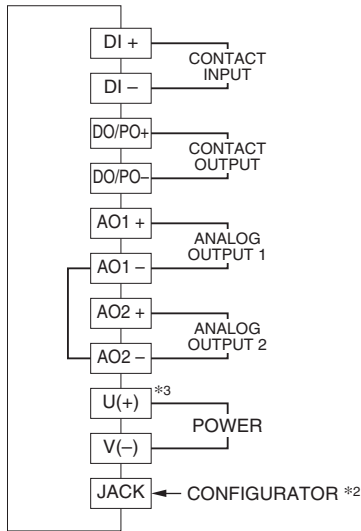

■ EXTERNAL INTERFACE CODE: 6, 7

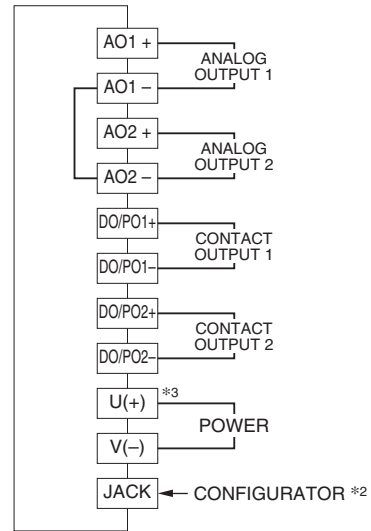

■ EXTERNAL INTERFACE CODE: 8

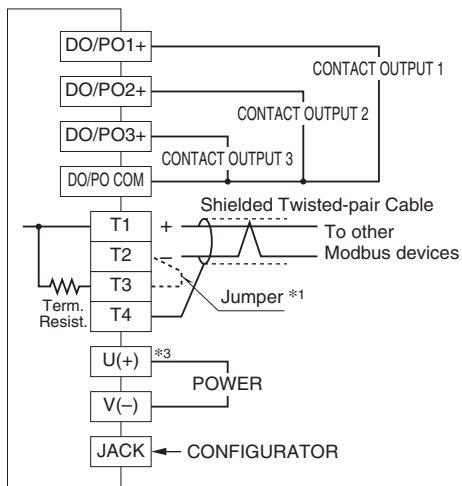

■ EXTERNAL INTERFACE CODE: 9

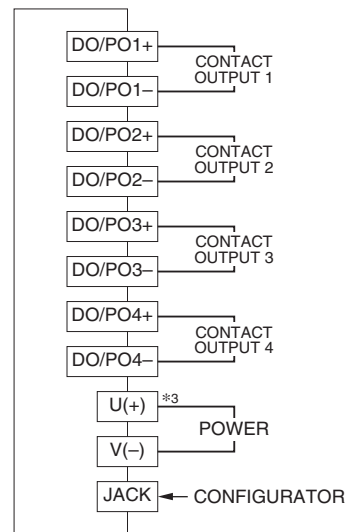

• Contact Input Connection E.g.

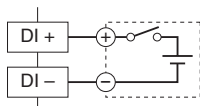

• Contact Output Connection E.g.

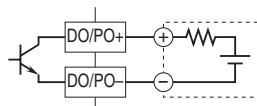

- *1. When the device is located at the end of a transmission line via twisted-pair cable, (when there is no cross-wiring), close across the terminal T2 – T3 with a leadwire. When the device is not at the end, no shortcircuit wire is required.
- *2. Analog output may momentarily fluctuate while the configurator cable is left connected.
- *3. For UL approved model, L and N are marked, instead of U(+) and V(-).

MODBUS WIRING CONNECTION

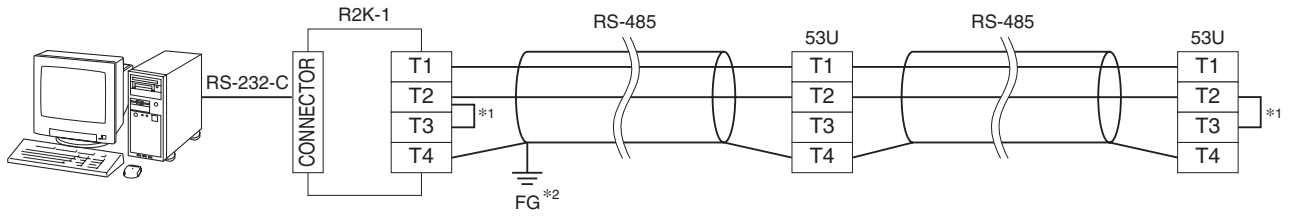

- *1. Internal terminating resistor is used when the device is at the end of a transmission line.
- *2. Install shield cables to all sections and ground them at single point.

SYSTEM CONFIGURATION EXAMPLES

■ RS-485 / RS-232-C

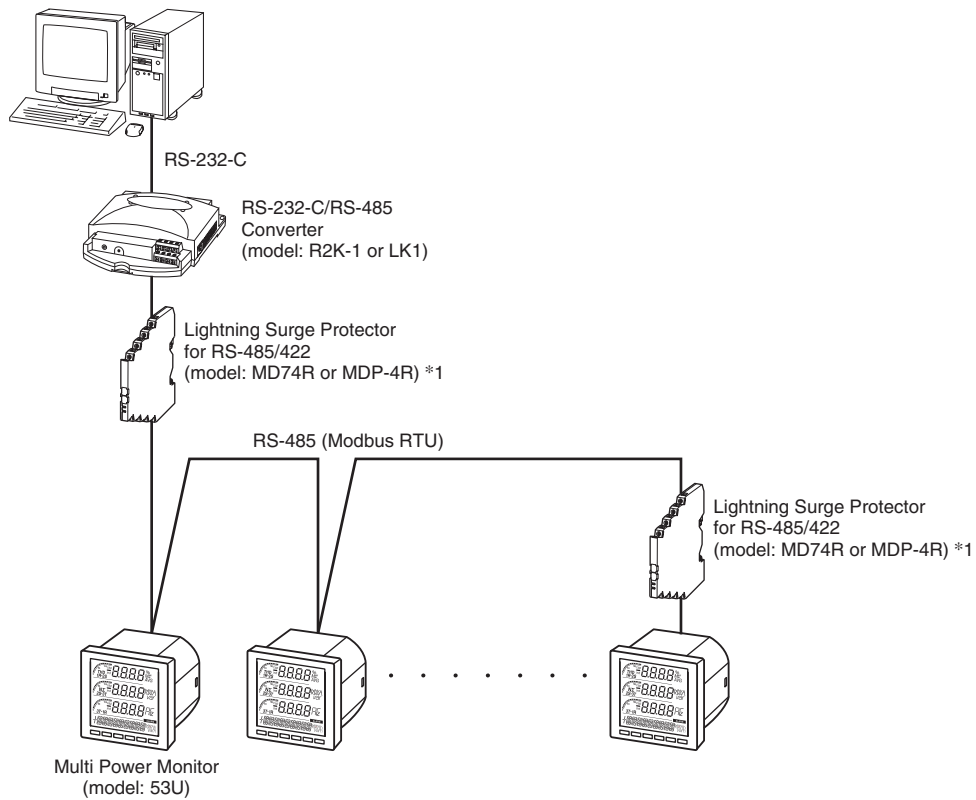

■ RS-485 / ETHERNET

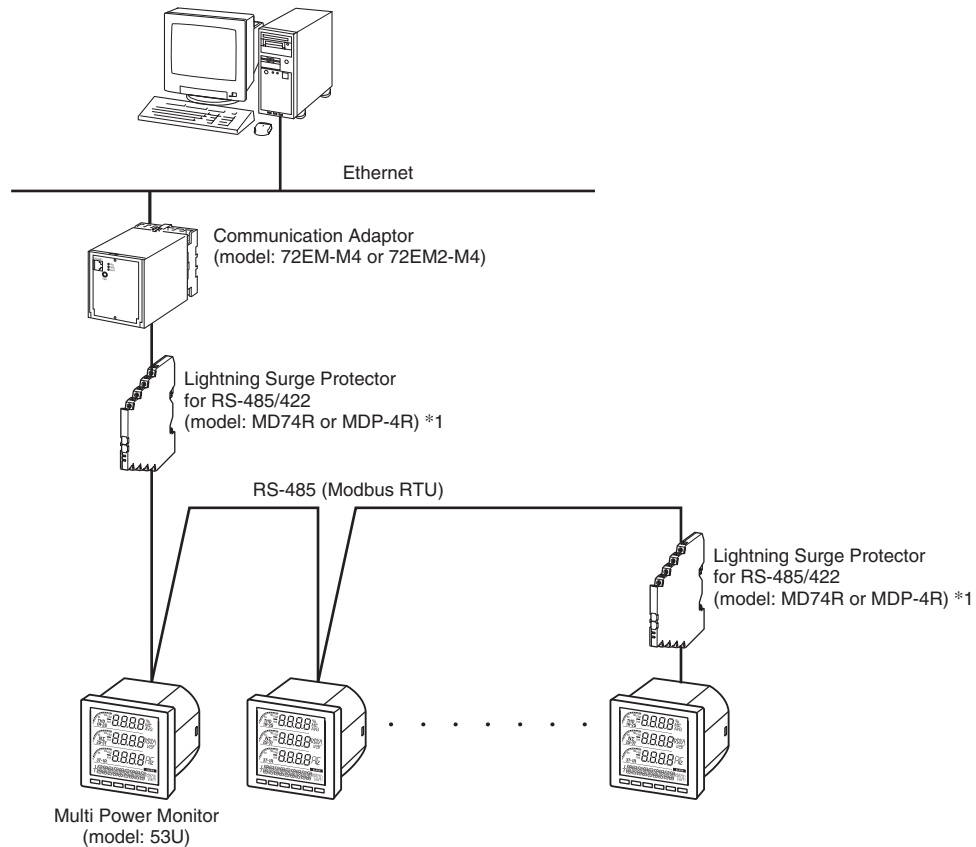

*1. Insert lightning surge protectors recommended in this example if necessary.

MODBUS - BASICS

This device conforms with Modbus-RTU protocol (MODBUS APPLICATION PROTOCOL V1.1a / Modbus over Serial Line Specification & Implementation Guide V1.0).

The following communication parameters are selectable.

COMM. PROPERTY	SELECTION
Modbus address	1 to 247
Baud rate	1200 bps 2400 bps 4800 bps 9600 bps 19200 bps 38400 bps (*)
Parity bit	None Odd (*) Even
Stop bit	1 bit (*) 2 bits
T1.5 timer length	0 to 6.0, in 0.1 increments (Modbus protocol standard: 1.5)
T3.5 timer length	0 to 6.0, in 0.1 increments (Modbus protocol standard: 3.5)

(*) Factory setting

When appropriately set, the host PC connected via RS-485 can read measurands from and write configurations (setting) to the device.

All registers are assigned to Read Holding Registers, can be read out using this command. If reading an address with no assigned register is attempted, '0' is given.

Write Multiple Registers command is used to write registers. If writing an address with no assigned register is attempted, 'Exception' is given.

FUNCTION CODE	COMMAND	RECOMMENDED TIME OUT VALUE
03	Read Holding Registers	0.5 second
16	Write Multiple Registers	2 seconds

These commands enable reading measurands and writing configurations.

One (1) word registers are represented in 16-bit integers, while two (2) word registers are in 32-bit. All registers are in the form of integer unless specifically given in the explanations.

The lower digit word in a 32-bit register is assigned to the lower address (n), while the upper digit word is assigned to the higher address (n+1). The order can be reversed by programming.

The 32-bit register must be read out and written in single command sequence.

CAUTION : DO NOT apply new setting via Modbus and the front control buttons at once.

It is recommended to wait for a time period indicated under 'recommended time out value' in the above table to receive a response for a command. If no response is received for these time periods, take appropriate error processing such as retrying.

MODBUS - OPERATIONS

Modbus registers are assigned to program and operate the unit via Modbus network. It can also disable the view switching control via the front keys to fix the display view to a specific parameter combination.

■ MODBUS REGISTER ACCESS SETTING

ADDR.	WORD	PARAMETER
4943	2	<p>Deactivate Modbus register writing protection 1.01</p> <p>Writing a preset passcode in this register deactivates the writing protection via Modbus.</p> <p>When the Modbus passcode set in this register matches the preset one, setting '1' or '2' in the register address 4945 becomes available to enable writing in Modbus registers.</p> <p>Reading out the register value is not possible. It reads always '-1' regardless of the code setting.</p> <p>After writing is complete, be sure to set a value other than the passcode ('0' is recommended) to activate the writing protection again.</p>
4945	1	<p>Modbus register access setting</p> <p>0 : Write disable (*)</p> <p>1 : Write enable</p> <p>2 : Write enable the count values</p> <p>Other : Write disable</p> <p>This setting is erased when the power supply to the unit is removed. It always starts with '0' (Write disable) when the power supply is turned on. Set '1' or '2' before starting writing at other registers.</p> <p>In order to write a count value (e.g. active energy), set '2' at this register address. When it is set, the unit stops counting so that a new count value can be written in the register address. Be careful to use '2' setting because no counting will be performed if the unit remains with this setting.</p> <p>When the Modbus register writing protection is enabled, this register setting cannot be changed from '0' to '1' or '2' unless a correct security code is set in the register address 4943.</p>

■ USER OPERATIONS

User operations include switching the display views and resetting alarm trips.

ADDR.	WORD	PARAMETER
5201	1	<p>Key operation lock</p> <p>0 : All key operations available (*)</p> <p>1 : All key operations locked</p> <p>2 : Lock the key operation to go to Setting mode only</p>
5202	1	<p>Data reading display</p> <p>Shows the parameter set displayed on the three data displays. The display can be switched by writing at this address from the host.</p>
5203	1	<p>Energy reading display</p> <p>Shows the parameter type displayed on the bottom data display. The display can be switched by writing at this address from the host.</p>
5204	1	<p>Energy reading display unit</p> <p>0 : 0.1 kWh, 0.1 kvarh, 0.1 kVA (*)</p> <p>1 : 0.1 Wh, 0.1 varh, 0.1 VA</p> <p>Shows the unit (factor) of the parameter on the energy display (k = kilo). The display unit can be switched by writing at this address from the host.</p> <p>Exception: Count time (unit: h) is displayed always 'without kilo'.</p>
5205	1	<p>Reset alarm trip</p> <p>1 : Reset</p> <p>0 : No resetting</p>
5206	1	<p>Automatic Σ view switching</p> <p>0 : Disable automatic switching (*)</p> <p>1 : Enable automatic switching: Σ1 through Σ4 switched in 10 second intervals. Automatic switching is cancelled when one of the front control buttons are touched.</p>

■ SYSTEM OPERATIONS

System operations include switching the tariff or resetting energy counts, and rebooting.

ADDR.	WORD	PARAMETER
5329	1	Switch tariff 0 : High tariff (peak time) (*) 1 : Low tariff (off-peak time)
5330	1	Reset energy count 1 : Reset all values 2 : Reset all MAX / MIN values and set the present values. 3 : Reset all average (demand) values 0 : No resetting Specify the extent of count resetting. The register is automatically set to '0' when the resetting procedure is complete after one of these values is written at this address. If another value is written before '0' has been set, the former resetting procedure ends indefinitely. Specific values can be preset to each register by writing at this address from the host.
5331	1	Reboot system Write '10001' to reboot the system. (Any other values can be written but invalid.)
5332	1	Backup / restore setting 20002 : Backup the present setting 30003 : Restore the device with the backup setting data The register is automatically set to '0' when the procedure is complete after one of these values is written at this address. If another value is written before '0' has been set, the former procedure ends indefinitely.
5333	1	Passcode 0000 to 9999 0000 : Factory setting Set and read out a passcode used to go into the Setting Mode using the front control keys.
5334	2	Modbus register writing protection passcode 1.01 Setting a passcode to control writing registers via Modbus. 1 to 999 999 999 0 : Cancel writing protection (*) The Modbus passcode must be set to the register address 4943 before setting '1' or '2' in the address 4945 to deactivate the writing protection. The value in this register is encrypted when it is read out. Only '0' (Cancel protection) is read out as it is. When a new code is set in this register, the register address 4945 is immediately reset to '0' so that a next command will be already limited in access.

MODBUS - SETTING

■ SYSTEM SETTING

ADDR.	WORD	PARAMETER	UNIT
5601	1	System configuration 0 : Single-phase / 2-wire (1CT) 1 : Single-phase / 3-wire (2CT) 2 : 3-phase / 3-wire, balanced load (1CT) 3 : 3-phase / 3-wire, unbalanced load (2CT) 4 : 3-phase / 4-wire, balanced load (1CT) 5 : 3-phase / 4-wire, unbalanced load (3CT) (*)	
5602	1	CT rating, Primary 1 to 20 000 : Current (A) Factory setting : 1 or 5	A
5603	1	CT rating, Secondary 1 : 1A 5 : 5A Factory setting : 1 or 5	A
5604	1	VT rating, Primary 50 to 400 000 : Voltage (V) Factory setting : 110	V
5606	1	VT rating, Secondary 50 to 500 : Voltage (V) Factory setting : 110	V
5607	1	Frequency input 0 : Voltage (*) 1 : Current	----
5608	1	Low-end cutout, Current 0 to 999 : Rated current \times 0.001 \times Specified value Factory setting : 10	%/10
5609	1	Low-end cutout, Voltage 0 to 999 : Rated voltage \times 0.001 \times Specified value Factory setting : 10	%/10

■ MODBUS SETTING

The device must be reset or the power supply to it must be turned off and on in order to enable the Modbus setting.

ADDR.	WORD	PARAMETER
5729	1	Modbus address 1 to 247 Factory setting : 1
5730	1	Baud rate 0 : 1200 1 : 2400 2 : 4800 3 : 9600 4 : 19200 5 : 38400 (*)
5731	1	Parity bit 0 : None 1 : Odd (*) 2 : Even
5732	1	Stop bit 0 : 1 bit (*) 1 : 2 bits
5733	1	T1.5 timer length 1 to 60 : Specified value \times 0.1 character length Factory setting : 15
5734	1	T3.5 timer length 1 to 60 : Specified value \times 0.1 character length Factory setting : 35
5735	1	Long register (32-bit words assignments) 0 : Normal (*) Lower digit word at the lower address 1 : Swap Lower digit word at the higher address

■ DEMAND SETTING

ADDR.	WORD	PARAMETER	UNIT
5857	1	Average (demand) current update interval 0 : External trigger signal 1 to 60 : Minutes Factory setting : 30	Minutes
5858	1	Average (demand) power update interval 0 : External trigger signal 1 to 60 : Minutes Factory setting : 30	Minutes

■ STYLE SETTING

ADDR.	WORD	PARAMETER
5985	1	Input line indication 0 : 1 - 2 - 3 (*) 1 : R - S - T
5986	1	Phase difference direction indication 0 : IND / CAP (*) 1 : LEAD / LAG
5987	1	Power factor (PF1 through PF3, PF) sign 0 : Standard (IEC) (*) Identical to the active energy 1 : Special type 1 (IEEE) Positive in LAG, Negative in LEAD
5988	1	Reactive power (Q1 through Q3, Q) sign 0 : Standard (IEC) (*) Positive from [PF = 1.0] to 180° in LAG direction; Negative for the other direction 1 : Special type 1 Positive in LAG, Negative in LEAD
5989	1	Reactive power (Q1 through Q3) calculation (Q = Q1 + Q2 + Q3) 0 : Standard (*) $Q_n = \sqrt{S_n^2 - P_n^2}$ 1 : Reactive power meter method $Q_n = \frac{1}{N_{smp}} \sum_{i=1}^{N_{smp}} (U_{ni} - N_{ui}) I_{i+(N_{smp}/4)}$
5990	1	Apparent power (S) calculation 0 : Standard (*) $S = \sqrt{P^2 + Q^2}$ 1 : Sum $S = S1 + S2 + S3$
5991	1	Unit used to indicate power up to 9999 2.00 0 : With 'k' (0.000 k) (*) 1 : Without 'k' (0000)

Note: '1,' '2,' '3' in expressions like Q1, Q2, Q3 indicate 'R,' 'S,' 'T' respectively.

■ DISCRETE I/O SETTING DO DI

ADDR.	WORD	PARAMETER
6113	1	Discrete output 1 function 0 : Undefined (*) 1 : Energy count 2 : Alarm
6114	1	Discrete output 1 contact type 0 : Normally open contact (*) 1 : Normally closed contact The contact opens at the power OFF regardless of this setting.
6115	1	Discrete input function 0 : Undefined (*) 1 : Update demand 2 : Reset energy count 3 : Reset alarm trip 4 : Tariff setting for Energy count (ON: high tariff)
6116	1	Discrete input contact type 0 : Normally open contact (*) 1 : Normally closed contact
6117	1	Discrete output 2 function 0 : Undefined (*) 1 : Energy count 2 : Alarm
6118	1	Discrete output 2 contact type 0 : Normally open contact (*) 1 : Normally closed contact The contact opens at the power OFF regardless of this setting.

ADDR.	WORD	PARAMETER
6121	1	Discrete output 3 function 0 : Undefined (*) 1 : Energy count 2 : Alarm
6122	1	Discrete output 3 contact type 0 : Normally open contact (*) 1 : Normally closed contact The contact opens at the power OFF regardless of this setting.
6125	1	Discrete output 4 function 0 : Undefined (*) 1 : Energy count 2 : Alarm
6126	1	Discrete output 4 contact type 0 : Normally open contact (*) 1 : Normally closed contact The contact opens at the power OFF regardless of this setting.

ENERGY SETTING D0

ADDR.	WORD	PARAMETER	UNIT
6241	1	Energy count 1 assigned to the discrete output 1 Refer to the table in the following page.	----
6242	2	Pulse weight for Energy count 1 0 : No pulse output (disabled) 1 to 100 000 : Specified value × 0.1 (kWh / kvarh / kVA) Factory setting : 10	kWh / 10 kvarh / 10 kVA / 10
6244	1	Pulse duration (width) for Energy count 1 1 to 20 : Specified value × 100 msec. Factory setting : 1	sec / 10
6245	1	Tariff setting for Energy count 1 0 : Disable (*) 1 : Enable	----
6246	1	Energy count 2 assigned to the discrete output 2 Refer to the table in the following page.	----
6247	2	Pulse weight for Energy count 2 0 : No pulse output (disabled) 1 to 100 000 : Specified value × 0.1 (kWh / kvarh / kVA) Factory setting : 10	kWh / 10 kvarh / 10 kVA / 10
6249	1	Pulse duration (width) for Energy count 2 1 to 20 : Specified value × 100 msec. Factory setting : 1	sec / 10
6250	1	Energy count 3 assigned to the discrete output 3 Refer to the table in the following page.	----
6251	2	Pulse weight for Energy count 3 0 : No pulse output (disabled) 1 to 100 000 : Specified value × 0.1 (kWh / kvarh / kVA) Factory setting : 10	kWh / 10 kvarh / 10 kVA / 10
6253	1	Pulse duration (width) for Energy count 3 1 to 20 : Specified value × 100 msec. Factory setting : 1	sec / 10
6254	1	Energy count 4 assigned to the discrete output 4 Refer to the table in the following page.	----
6255	2	Pulse weight for Energy count 4 0 : No pulse output (disabled) 1 to 100 000 : Specified value × 0.1 (kWh / kvarh / kVA) Factory setting : 10	kWh / 10 kvarh / 10 kVA / 10
6257	1	Pulse duration (width) for Energy count 4 1 to 20 : Specified value × 100 msec. Factory setting : 1	sec / 10

Energy count type

SET VALUE	ID	PARAMETER	
0	T-EP	Active energy, incoming (*)	
1	T-EQ	Reactive energy, LAG	
2	T-ES	Apparent energy	
3	T-EP-	Active energy, outgoing	
4	T-EQ-	Reactive energy, LEAD	
5	T-EQ+LAG	Reactive energy, incoming, LAG	
6	T-EQ+LEAD	Reactive energy, incoming, LEAD	
7	T-EQ-LAG	Reactive energy, outgoing, LAG	
8	T-EQ-LEAD	Reactive energy, outgoing, LEAD	
9	----	Reserved. DO NOT USE.	
10	T-EQ+P	Reactive energy, incoming	2.00
11	T-EQ-P	Reactive energy, outgoing	2.00
12	T-EPA	Active energy, (incoming – outgoing)	2.00
13	T-EQA	Reactive energy, (incoming + outgoing)	2.00
200	EP	Active energy, high tariff, incoming	2.00
201	EQ	Reactive energy, high tariff, LAG	2.00
202	ES	Apparent energy, high tariff	2.00
203	EP-	Active energy, high tariff, outgoing	2.00
204	EQ-	Reactive energy, high tariff, LEAD	2.00
205	EQ+LAG	Reactive energy, high tariff, incoming, LAG	2.00
206	EQ+LEAD	Reactive energy, high tariff, incoming, LEAD	2.00
207	EQ-LAG	Reactive energy, high tariff, outgoing, LAG	2.00
208	EQ-LEAD	Reactive energy, high tariff, outgoing, LEAD	2.00
209	----	Reserved. DO NOT USE.	2.00
210	EQ+P	Reactive energy, high tariff, incoming	2.00
211	EQ-P	Reactive energy, high tariff, outgoing	2.00
212	EPA	Active energy, high tariff, (incoming – outgoing)	2.00
213	EQA	Reactive energy, high tariff, (incoming + outgoing)	2.00
300	L-EP	Active energy, low tariff, incoming	2.00
301	L-EQ	Reactive energy, low tariff, LAG	2.00
302	L-ES	Apparent energy, low tariff	2.00
303	L-EP-	Active energy, low tariff, outgoing	2.00
304	L-EQ-	Reactive energy, low tariff, LEAD	2.00
305	L-EQ+LAG	Reactive energy, low tariff, incoming, LAG	2.00
306	L-EQ+LEAD	Reactive energy, low tariff, incoming, LEAD	2.00
307	L-EQ-LAG	Reactive energy, low tariff, outgoing, LAG	2.00
308	L-EQ-LEAD	Reactive energy, low tariff, outgoing, LEAD	2.00
309	----	Reserved. DO NOT USE.	2.00
310	L-EQ+P	Reactive energy, low tariff, incoming	2.00
311	L-EQ-P	Reactive energy, low tariff, outgoing	2.00
312	L-EPA	Active energy, low tariff, (incoming – outgoing)	2.00
313	L-EQA	Reactive energy, low tariff, (incoming + outgoing)	2.00

ALARM SETTING

ADDR.	WORD	PARAMETER	UNIT
6369	1	Power ON delay time 0 to 999 : Seconds Factory setting : 0	Seconds
6370	1	Latching 0 : No latching (*) 1 : Latching (Alarm trip is held until a reset command is received or power OFF)	----
6371	2	I1 thr. I3 - Current : High setpoint Factory setting : 0	mA
6373	2	I1 thr. I3 - Current : Low setpoint Factory setting : 0	mA
6375	1	I1 thr. I3 - Current : Alarm output 0 : Disable (*) 1 : Display only 2 : Display + contact output	----
6376	1	I1 thr. I3 - Current : Hysteresis (deadband) 0 to 999 : Specified value × 0.1 (%) Factory setting : 0	%/10
6377	1	I1 thr. I3 - Current : ON delay time 0 to 999 : Seconds Factory setting : 0	Seconds
6379	2	IN - Neutral current : High setpoint Factory setting : 0	mA
6381	2	IN - Neutral current : Low setpoint Factory setting : 0	mA
6383	1	IN - Neutral current : Alarm output 0 : Disable (*) 1 : Display only 2 : Display + contact output	----
6384	1	IN - Neutral current : Hysteresis (deadband) 0 to 999 : Specified value × 0.1 (%) Factory setting : 0	%/10
6385	1	IN - Neutral current : ON delay time 0 to 999 : Seconds Factory setting : 0	Seconds
6387	2	U12 thr. U31 - Delta voltage : High setpoint Factory setting : 0	V/100
6389	2	U12 thr. U31 - Delta voltage : Low setpoint Factory setting : 0	V/100
6391	1	U12 thr. U31 - Delta voltage : Alarm output 0 : Disable (*) 1 : Display only 2 : Display + contact output	----
6392	1	U12 thr. U31 - Delta voltage : Hysteresis (deadband) 0 to 999 : Specified value × 0.1 (%) Factory setting : 0	%/10
6393	1	U12 thr. U31 - Delta voltage : ON delay time 0 to 999 : Seconds Factory setting : 0	Seconds
6395	2	U1N thr. U3N - Phase voltage : High setpoint Factory setting : 0	V/100
6397	2	U1N thr. U3N - Phase voltage : Low setpoint Factory setting : 0	V/100
6399	1	U1N thr. U3N - Phase voltage : Alarm output 0 : Disable (*) 1 : Display only 2 : Display + contact output	----
6400	1	U1N thr. U3N - Phase voltage : Hysteresis (deadband) 0 to 999 : Specified value × 0.1 (%) Factory setting : 0	%/10
6401	1	U1N thr. U3N - Phase voltage : ON delay time 0 to 999 : Seconds Factory setting : 0	Seconds

ADDR.	WORD	PARAMETER	UNIT
6403	2	P - Active power : High setpoint Factory setting : 0	W
6405	2	P - Active power : Low setpoint Factory setting : 0	W
6407	1	P - Active power : Alarm output 0 : Disable (*) 1 : Display only 2 : Display + contact output	----
6408	1	P - Active power : Hysteresis (deadband) 0 to 999 : Specified value × 0.1 (%) Factory setting : 0	%/10
6409	1	P - Active power : ON delay time 0 to 999 : Seconds Factory setting : 0	Seconds
6411	2	Q - Reactive power : High setpoint Factory setting : 0	var
6413	2	Q - Reactive power : Low setpoint Factory setting : 0	var
6415	1	Q - Reactive power : Alarm output 0 : Disable (*) 1 : Display only 2 : Display + contact output	----
6416	1	Q - Reactive power : Hysteresis (deadband) 0 to 999 : Specified value × 0.1 (%) Factory setting : 0	%/10
6417	1	Q - Reactive power : ON delay time 0 to 999 : Seconds Factory setting : 0	Seconds
6419	2	S - Apparent power : High setpoint Factory setting : 0	VA
6421	2	S - Apparent power : Low setpoint Factory setting : 0	VA
6423	1	S - Apparent power : Alarm output 0 : Disable (*) 1 : Display only 2 : Display + contact output	----
6424	1	S - Apparent power : Hysteresis (deadband) 0 to 999 : Specified value × 0.1 (%) Factory setting : 0	%/10
6425	1	S - Apparent power : ON delay time 0 to 999 : Seconds Factory setting : 0	Seconds
6427	2	PF - Power factor : High setpoint Factory setting : 0	%/100
6429	2	PF - Power factor : Low setpoint Factory setting : 0	%/100
6431	1	PF - Power factor : Alarm output 0 : Disable (*) 1 : Display only 2 : Display + contact output	----
6432	1	PF - Power factor : Hysteresis (deadband) 0 to 999 : Specified value × 0.1 (%) Factory setting : 0	%/10
6433	1	PF - Power factor : ON delay time 0 to 999 : Seconds Factory setting : 0	Seconds

ADDR.	WORD	PARAMETER	UNIT
6435	2	F - Frequency : High setpoint Factory setting : 6500	Hz/100
6437	2	F - Frequency : Low setpoint Factory setting : 4500	Hz/100
6439	1	F - Frequency : Alarm output 0 : Disable (*) 1 : Display only 2 : Display + contact output	----
6440	1	F - Frequency : Hysteresis (deadband) 0 to 999 : Specified value × 0.1 (%) Factory setting : 0	%/10
6441	1	F - Frequency : ON delay time 0 to 999 : Seconds Factory setting : 0	Seconds
6443	2	I1 AVG thr. I3 AVG - Average (demand) current : High setpoint Factory setting : 0	mA
6445	2	I1 AVG thr. I3 AVG - Average (demand) current : Low setpoint Factory setting : 0	mA
6447	1	I1 AVG thr. I3 AVG - Average (demand) current : Alarm output 0 : Disable (*) 1 : Display only 2 : Display + contact output	----
6448	1	I1 AVG thr. I3 AVG - Average (demand) current : Hysteresis (deadband) 0 to 999 : Specified value × 0.1 (%) Factory setting : 0	%/10
6449	1	I1 AVG thr. I3 AVG - Average (demand) current : ON delay time 0 to 999 : Seconds Factory setting : 0	Seconds
6451	2	IN AVG - Average (demand) neutral current : High setpoint Factory setting : 0	mA
6453	2	IN AVG - Average (demand) neutral current : Low setpoint Factory setting : 0	mA
6455	1	IN AVG - Average (demand) neutral current : Alarm output 0 : Disable (*) 1 : Display only 2 : Display + contact output	----
6456	1	IN AVG - Average (demand) neutral current : Hysteresis (deadband) 0 to 999 : Specified value × 0.1 (%) Factory setting : 0	%/10
6457	1	IN AVG - Average (demand) neutral current : ON delay time 0 to 999 : Seconds Factory setting : 0	Seconds
6459	2	P AVG - Average (demand) active power : High setpoint Factory setting : 0	W
6461	2	P AVG - Average (demand) active power : Low setpoint Factory setting : 0	W
6463	1	P AVG - Average (demand) active power : Alarm output 0 : Disable (*) 1 : Display only 2 : Display + contact output	----
6464	1	P AVG - Average (demand) active power : Hysteresis (deadband) 0 to 999 : Specified value × 0.1 (%) Factory setting : 0	%/10
6465	1	P AVG - Average (demand) active power : ON delay time 0 to 999 : Seconds Factory setting : 0	Seconds

ADDR.	WORD	PARAMETER	UNIT
6467	2	Q AVG - Average (demand) reactive power : High setpoint Factory setting : 0	var
6469	2	Q AVG - Average (demand) reactive power : Low setpoint Factory setting : 0	var
6471	1	Q AVG - Average (demand) reactive power : Alarm output 0 : Disable (*) 1 : Display only 2 : Display + contact output	----
6472	1	Q AVG - Average (demand) reactive power : Hysteresis (deadband) 0 to 999 : Specified value × 0.1 (%) Factory setting : 0	%/10
6473	1	Q AVG - Average (demand) reactive power : ON delay time 0 to 999 : Seconds Factory setting : 0	Seconds
6475	2	S AVG - Average (demand) apparent power : High setpoint Factory setting : 0	VA
6477	2	S AVG - Average (demand) apparent power : Low setpoint Factory setting : 0	VA
6479	1	S AVG - Average (demand) apparent power : Alarm output 0 : Disable (*) 1 : Display only 2 : Display + contact output	----
6480	1	S AVG - Average (demand) apparent power : Hysteresis (deadband) 0 to 999 : Specified value × 0.1 (%) Factory setting : 0	%/10
6481	1	S AVG - Average (demand) apparent power : ON delay time 0 to 999 : Seconds Factory setting : 0	Seconds
6483	2	THDI1 thr. THDI3 - Current total harmonic distortion : High setpoint Factory setting : 0	%/10
6485	2	THDI1 thr. THDI3 - Current total harmonic distortion : Low setpoint Factory setting : 0	%/10
6487	1	THDI1 thr. THDI3 - Current total harmonic distortion : Alarm output 0 : Disable (*) 1 : Display only 2 : Display + contact output	----
6488	1	THDI1 thr. THDI3 - Current total harmonic distortion : Hysteresis (deadband) 0 to 999 : Specified value × 0.1 (%) Factory setting : 0	%/10
6489	1	THDI1 thr. THDI3 - Current total harmonic distortion : ON delay time 0 to 999 : Seconds Factory setting : 0	Seconds
6491	2	THDIN - Neutral current total harmonic distortion : High setpoint Factory setting : 0	%/10
6493	2	THDIN - Neutral current total harmonic distortion : Low setpoint Factory setting : 0	%/10
6495	1	THDIN - Neutral current total harmonic distortion : Alarm output 0 : Disable (*) 1 : Display only 2 : Display + contact output	----
6496	1	THDIN - Neutral current total harmonic distortion : Hysteresis (deadband) 0 to 999 : Specified value × 0.1 (%) Factory setting : 0	%/10
6497	1	THDIN - Neutral current total harmonic distortion : ON delay time 0 to 999 : Seconds Factory setting : 0	Seconds

ADDR.	WORD	PARAMETER	UNIT
6499	2	THDU12 thr. THDU31 - Delta voltage total harmonic distortion : High setpoint Factory setting : 0	%/10
6501	2	THDU12 thr. THDU31 - Delta voltage total harmonic distortion : Low setpoint Factory setting : 0	%/10
6503	1	THDU12 thr. THDU31 - Delta voltage total harmonic distortion : Alarm output 0 : Disable (*) 1 : Display only 2 : Display + contact output	----
6504	1	THDU12 thr. THDU31 - Delta voltage total harmonic distortion : Hysteresis (deadband) 0 to 999 : Specified value × 0.1 (%) Factory setting : 0	%/10
6505	1	THDU12 thr. THDU31 - Delta voltage total harmonic distortion : ON delay time 0 to 999 : Seconds Factory setting : 0	Seconds
6507	2	THDU1N thr. THDU3N - Phase voltage total harmonic distortion : High setpoint Factory setting : 0	%/10
6509	2	THDU1N thr. THDU3N - Phase voltage total harmonic distortion : Low setpoint Factory setting : 0	%/10
6511	1	THDU1N thr. THDU3N - Phase voltage total harmonic distortion : Alarm output 0 : Disable (*) 1 : Display only 2 : Display + contact output	----
6512	1	THDU1N thr. THDU3N - Phase voltage total harmonic distortion : Hysteresis (deadband) 0 to 999 : Specified value × 0.1 (%) Factory setting : 0	%/10
6513	1	THDU1N thr. THDU3N - Phase voltage total harmonic distortion : ON delay time 0 to 999 : Seconds Factory setting : 0	Seconds
6515	2	UT12 thr. UT31 - Phase angle between phase voltages : High setpoint 2.00 Factory setting : 0	°
6517	2	UT12 thr. UT31 - Phase angle between phase voltages : Low setpoint 2.00 Factory setting : 0	°
6519	1	UT12 thr. UT31 - Phase angle between phase voltages : Alarm output 2.00 0 : Disable (*) 1 : Display only 2 : Display + contact output	----
6520	1	UT12 thr. UT31 - Phase angle between phase voltages : Hysteresis (deadband) 2.00 0 to 999 : Specified value × 0.1 (%) Factory setting : 0	%/10
6521	1	UT12 thr. UT31 - Phase angle between phase voltages : ON delay time 2.00 0 to 999 : Seconds Factory setting : 0	Seconds

■ LCD SETTING

ADDR.	WORD	PARAMETER
6625	1	LCD backlight operating mode (The backlight turns on regardless of this setting in case of alarms/errors.) 0 : AUTO (*) ON at alarm and operating; OFF after the OFF TIMER time has been elapsed after the last operating. 1 : ON Continuously ON 2 : OFF Continuously OFF
6626	1	LCD backlight OFF timer 1 to 999 : Seconds Time to be elapsed after the last operating before the backlight is turned off. Factory setting : 600
6627	1	LCD backlight brightness 1 to 3 (dark) 1 << brightness >> 3 (bright) Factory setting : 2
6628	1	LCD update rate 2.00 0 to 60 : Seconds Display data updating rate. Set '0' for the maximum possible rate. Factory setting : 0

■ LCD BARGRAPH SETTING

The bargraph is indicated proportionally to the specified rating (100%). For the energy values, it indicates [Current × Voltage] as 100%.

ADDR.	WORD	PARAMETER	UNIT
6753	1	Current 100% 1 to 20 000 : Current (A) Factory setting : 1 or 5	A
6754	2	Voltage 100% 1 to 400 000 : Voltage (V) Factory setting : 300	V

■ 'MY DEFAULT' SETTING

Custom default view setting

ADDR.	WORD	PARAMETER	UNIT
6881	1	'My default' time 0 : Disable (*) 1 to 999 : Seconds The display returns to the preset view if the control keys are untouched for the preset time.	Seconds
6882	1	'My default' data display view Shows the parameter set displayed on 'My default' view. -1 : Automatic cyclic switching of Σ1 through Σ4 as 'My default' view. 2.00	----
6883	1	'My default' energy display view Shows the parameter type displayed on the bottom data display.	----
6884	1	'My default' energy reading display unit 0 : 0.1 kWh, 0.1 kvarh, 0.1 kVA (*) 1 : 0.1 Wh, 0.1 varh, 0.1 VA Shows the unit (factor) of the parameter on the energy display (k = kilo).	----

ANALOG OUTPUT A0

OUTPUT 1 ADDR.	OUTPUT 2 ADDR.	OUTPUT 3 ADDR.	OUTPUT 4 ADDR.	WORD	PARAMETER
7009	7039	7069	7099	1	Analog output 1 thr. 4 - Measurand to be assigned Refer to the table in the following page.
7010	7040	7070	7100	1	Analog output 1 thr. 4 - Zero adjustment -500 to +500 : %/100 Factory setting : 0
7011	7041	7071	7101	1	Analog output 1 thr. 4 - Span adjustment 9 500 to 10 500 : %/100 Factory setting : 10 000
7012	7042	7072	7102	1	Analog output 1 thr. 4 - Linearization 0 : Proportional output (*) 1 : Linearized output using the calibration table
7013	7043	7073	7103	1	Analog output 1 thr. 4 - Input 0% -1 500 to +14 000 : %/100 Factory setting : 0
7014	7044	7074	7104	1	Analog output 1 thr. 4 - Output 0% 160 to 5 600 : mA/100 (4 – 20mA) or mV (1 – 5V) Factory setting : 400 (4 – 20mA) or 1 000 (1 – 5V)
7015	7045	7075	7105	1	Analog output 1 thr. 4 - Input 100% -1 500 to +14 000 : %/100 Factory setting : 10 000
7016	7046	7076	7106	1	Analog output 1 thr. 4 - Output 100% 160 to 5 600 : mA/100 (4 – 20mA) or mV (1 – 5V) Factory setting : 2 000 (4 – 20mA) or 5 000 (1 – 5V)
7017	7047	7077	7107	1	Analog output 1 thr. 4 - Calibration point 0 input -1 500 to +14 000 : %/100 Factory setting : 0
7018	7048	7078	7108	1	Analog output 1 thr. 4 - Calibration point 0 output 160 to 5 600 : mA/100 (4 – 20mA) or mV (1 – 5V) Factory setting : 400 (4 – 20mA) or 1 000 (1 – 5V)
7019	7049	7079	7109	1	Analog output 1 thr. 4 - Calibration point 1 input -1 500 to +14 000 : %/100 Factory setting : 0
7020	7050	7080	7110	1	Analog output 1 thr. 4 - Calibration point 1 output 160 to 5 600 : mA/100 (4 – 20mA) or mV (1 – 5V) Factory setting : 400 (4 – 20mA) or 1 000 (1 – 5V)
7021	7051	7081	7111	1	Analog output 1 thr. 4 - Calibration point 2 input -1 500 to +14 000 : %/100 Factory setting : 0
7022	7052	7082	7112	1	Analog output 1 thr. 4 - Calibration point 2 output 160 to 5 600 : mA/100 (4 – 20mA) or mV (1 – 5V) Factory setting : 400 (4 – 20mA) or 1 000 (1 – 5V)
7023	7053	7083	7113	1	Analog output 1 thr. 4 - Calibration point 3 input -1 500 to +14 000 : %/100 Factory setting : 0
7024	7054	7084	7114	1	Analog output 1 thr. 4 - Calibration point 3 output 160 to 5 600 : mA/100 (4 – 20mA) or mV (1 – 5V) Factory setting : 400 (4 – 20mA) or 1 000 (1 – 5V)
7025	7055	7085	7115	1	Analog output 1 thr. 4 - Calibration point 4 input -1 500 to +14 000 : %/100 Factory setting : 0
7026	7056	7086	7116	1	Analog output 1 thr. 4 - Calibration point 4 output 160 to 5 600 : mA/100 (4 – 20mA) or mV (1 – 5V) Factory setting : 400 (4 – 20mA) or 1 000 (1 – 5V)
7027	7057	7087	7117	1	Analog output 1 thr. 4 - Calibration point 5 input -1 500 to +14 000 : %/100 Factory setting : 0
7028	7058	7088	7118	1	Analog output 1 thr. 4 - Calibration point 5 output 160 to 5 600 : mA/100 (4 – 20mA) or mV (1 – 5V) Factory setting : 400 (4 – 20mA) or 1 000 (1 – 5V)
7029	7059	7089	7119	1	Analog output 1 thr. 4 - Calibration point 6 input -1 500 to +14 000 : %/100 Factory setting : 0
7030	7060	7090	7120	1	Analog output 1 thr. 4 - Calibration point 6 output 160 to 5 600 : mA/100 (4 – 20mA) or mV (1 – 5V) Factory setting : 400 (4 – 20mA) or 1 000 (1 – 5V)

OUTPUT 1 ADDR.	OUTPUT 2 ADDR.	OUTPUT 3 ADDR.	OUTPUT 4 ADDR.	WORD	PARAMETER
7031	7061	7091	7121	1	Analog output 1 thr. 4 - Calibration point 7 input -1 500 to +14 000 : %/100 Factory setting : 0
7032	7062	7092	7122	1	Analog output 1 thr. 4 - Calibration point 7 output 160 to 5 600 : mA/100 (4 – 20mA) or mV (1 – 5V) Factory setting : 400 (4 – 20mA) or 1 000 (1 – 5V)
7033	7063	7093	7123	1	Analog output 1 thr. 4 - Calibration point 8 input -1 500 to +14 000 : %/100 Factory setting : 0
7034	7064	7094	7124	1	Analog output 1 thr. 4 - Calibration point 8 output 160 to 5 600 : mA/100 (4 – 20mA) or mV (1 – 5V) Factory setting : 400 (4 – 20mA) or 1 000 (1 – 5V)
7035	7065	7095	7125	1	Analog output 1 thr. 4 - Calibration point 9 input -1 500 to +14 000 : %/100 Factory setting : 0
7036	7066	7096	7126	1	Analog output 1 thr. 4 - Calibration point 9 output 160 to 5 600 : mA/100 (4 – 20mA) or mV (1 – 5V) Factory setting : 400 (4 – 20mA) or 1 000 (1 – 5V)

Analog output type

SET VALUE	ID	PARAMETER
0	NO ASSIGN	Undefined (*)
1	I	Current
2	U	Voltage
3	P	Active power
4	Q	Reactive power
5	S	Apparent power
6	PF	Power factor
7	F	Frequency
8	I1	Current, Line 1
9	I2	Current, Line 2
10	I3	Current, Line 3
11	IN	Neutral current
12	U12	Delta voltage, 1 – 2
13	U23	Delta voltage, 2 – 3
14	U31	Delta voltage, 3 – 1
15	U1N	Phase voltage, Phase 1
16	U2N	Phase voltage, Phase 2
17	U3N	Phase voltage, Phase 3
18	P1	Active power, Phase 1
19	P2	Active power, Phase 2
20	P3	Active power, Phase 3
21	Q1	Reactive power, Phase 1
22	Q2	Reactive power, Phase 2
23	Q3	Reactive power, Phase 3
24	S1	Apparent power, Phase 1
25	S2	Apparent power, Phase 2
26	S3	Apparent power, Phase 3
27	PF1	Power factor, Phase 1
28	PF2	Power factor, Phase 2
29	PF3	Power factor, Phase 3
30	THDI1	Current total harmonic distortion, Line 1
31	THDI2	Current total harmonic distortion, Line 2
32	THDI3	Current total harmonic distortion, Line 3
33	THDIN	Neutral current total harmonic distortion
34	THDU12	Delta voltage total harmonic distortion, 1 – 2
35	THDU23	Delta voltage total harmonic distortion, 2 – 3
36	THDU31	Delta voltage total harmonic distortion, 3 – 1
37	THDU1N	Phase voltage total harmonic distortion, Phase 1
38	THDU2N	Phase voltage total harmonic distortion, Phase 2
39	THDU3N	Phase voltage total harmonic distortion, Phase 3
43	T-Q	Reactive power for bidirectional current
44	T-PF	Power factor for bidirectional current

■ Σ VIEW DISPLAY PARAMETER SETTING 2.00

ADDR.	WORD	PARAMETER
7393	1	Σ1, Line 1 - Measurand to be assigned - Refer to the table below.
7394	1	Σ1, Line 2 - Measurand to be assigned - Refer to the table below.
7395	1	Σ1, Line 3 - Measurand to be assigned - Refer to the table below.
7397	1	Σ2, Line 1 - Measurand to be assigned - Refer to the table below.
7398	1	Σ2, Line 2 - Measurand to be assigned - Refer to the table below.
7399	1	Σ2, Line 3 - Measurand to be assigned - Refer to the table below.
7401	1	Σ3, Line 1 - Measurand to be assigned - Refer to the table below.
7402	1	Σ3, Line 2 - Measurand to be assigned - Refer to the table below.
7403	1	Σ3, Line 3 - Measurand to be assigned - Refer to the table below.
7405	1	Σ4, Line 1 - Measurand to be assigned - Refer to the table below.
7406	1	Σ4, Line 2 - Measurand to be assigned - Refer to the table below.
7407	1	Σ4, Line 3 - Measurand to be assigned - Refer to the table below.

Σ view measurands and selectable positions (lines, X = selectable) 2.00

SET VALUE	ID	PARAMETER	UNIT	LINE 1	LINE 2	LINE 3
0	NULL	Undefined	----	X	X	X
1	I	Current	A	X		
2	U	Voltage	V			X
3	P	Active power	W		X	
4	Q	Reactive power	var		X	
5	S	Apparent power	VA		X	
6	PF	Power factor	PF			X
7	F	Frequency	Hz			X

■ SHORTCUT MENU FUNCTION 2.00

ADDR.	WORD	PARAMETER
7553	1	Resetting alarm trip 0 : Disable 1 : Enable (*)

MODBUS - MEASURED VARIABLES

Measured variables, except for the nth harmonic distortion, are read out as signed 32-bit integer.

Each variable has different engineering unit (Refer to the table below). For example, when 40000 is read at the address 41 for the 1 – N delta voltage, the actual voltage value equals to $400.0V = 40000 \times 0.01$, as the engineering unit for this item is V/100 (0.01V).

Readable range for each parameter depends upon the parameter type, as shown in the table below. For example, Current unit is applied to Line current or Neutral current, and Voltage unit is applied to the 1 – N delta voltage or the minimum value voltage.

PARAMETER	UNIT	RANGE
Current	mA	0 to 2 000 000 000 mA
Voltage	V/100	0 to 20 000 000.00 V
Active power	W	-2 000 000 000 to 2 000 000 000 W
Reactive power	var	-2 000 000 000 to 2 000 000 000 var
Apparent power	VA	0 to 2 000 000 000 VA
Power factor	%/100	-1.0000 to 1.0000
Frequency	Hz/100	0 or 40.00 Hz to 70.00 Hz
Active energy	kWh/10	0 to 99 999 999.9 kWh (Reset to 0 when exceeding the max. value)
Reactive energy	kvarh/10	0 to 99 999 999.9 kvarh (Reset to 0 when exceeding the max. value)
Apparent energy	kVAh/10	0 to 99 999 999.9 kVAh (Reset to 0 when exceeding the max. value)
Active energy deviation	kWh/10	-99 999 999.9 to 99 999 999.9 kWh (Stops at either -99 999 999.9 or 99 999 999.9)
Energy count time	h/10	0 to 99 999 999.9 hours (Reset to 0 when exceeding the max. value)
Harmonic	%/10	0 to 999.9%
Phase angle between phase voltages	°	-180 to +180°

■ MOMENTARY VALUE

ADDR.	WORD	ID	PARAMETER	UNIT
1	2	I	Current	mA
3	2	U	Voltage	V/100
5	2	P	Active power	W
7	2	Q	Reactive power	var
9	2	S	Apparent power	VA
11	2	PF	Power factor	%/100
13	2	F	Frequency	Hz/100
15	2	DIR	Phase difference direction (0 = inductive or lag, 1 = capacitive or lead)	----
33	2	I1	Current, Line 1	mA
35	2	I2	Current, Line 2	mA
37	2	I3	Current, Line 3	mA
39	2	IN	Neutral current	mA
41	2	U12	Delta voltage, 1 – 2	V/100
43	2	U23	Delta voltage, 2 – 3	V/100
45	2	U31	Delta voltage, 3 – 1	V/100
47	2	U1N	Phase voltage, Phase 1	V/100
49	2	U2N	Phase voltage, Phase 2	V/100
51	2	U3N	Phase voltage, Phase 3	V/100
53	2	P1	Active power, Phase 1	W
55	2	P2	Active power, Phase 2	W
57	2	P3	Active power, Phase 3	W
59	2	Q1	Reactive power, Phase 1	var
61	2	Q2	Reactive power, Phase 2	var
63	2	Q3	Reactive power, Phase 3	var
65	2	S1	Apparent power, Phase 1	VA
67	2	S2	Apparent power, Phase 2	VA
69	2	S3	Apparent power, Phase 3	VA
71	2	PF1	Power factor, Phase 1	%/100
73	2	PF2	Power factor, Phase 2	%/100
75	2	PF3	Power factor, Phase 3	%/100
77	2	DIR1	Phase difference direction, Phase 1 (0 = inductive or lag, 1 = capacitive or lead)	----
79	2	DIR2	Phase difference direction, Phase 2 (0 = inductive or lag, 1 = capacitive or lead)	----
81	2	DIR3	Phase difference direction, Phase 3 (0 = inductive or lag, 1 = capacitive or lead)	----
83	2	UT12	Phase angle between Phase 1 – 2 voltages 2.00	°
85	2	UT23	Phase angle between Phase 2 – 3 voltages 2.00	°
87	2	UT31	Phase angle between Phase 3 – 1 voltages 2.00	°

■ ENERGY

Writing the following registers enables energy presetting. Set Modbus Register Access in order to write in the energy and fractions.

ADDR.	WORD	ID	PARAMETER	UNIT
129	2	EP	Active energy, high tariff, incoming	kWh/10
131	2	EQ	Reactive energy, high tariff, LAG	kvarh/10
133	2	ES	Apparent energy, high tariff	kVAh/10
135	2	EP-	Active energy, high tariff, outgoing	kWh/10
137	2	EQ-	Reactive energy, high tariff, LEAD	kvarh/10
139	2	EQ+LAG	Reactive energy, high tariff, incoming, LAG	kvarh/10
141	2	EQ+LEAD	Reactive energy, high tariff, incoming, LEAD	kvarh/10
143	2	EQ-LAG	Reactive energy, high tariff, outgoing, LAG	kvarh/10
145	2	EQ-LEAD	Reactive energy, high tariff, outgoing, LEAD	kvarh/10
147	2	TIMER	Energy count time, high tariff	h/10
149	2	EQ+P	Reactive energy, high tariff, incoming	2.00 kvarh/10
151	2	EQ-P	Reactive energy, high tariff, outgoing	2.00 kvarh/10
153	2	EPA	Active energy, high tariff, (incoming - outgoing)	2.00 kWh/10
155	2	EQA	Reactive energy, high tariff, (incoming + outgoing)	2.00 kvarh/10
161	2	L-EP	Active energy, low tariff, incoming	kWh/10
163	2	L-EQ	Reactive energy, low tariff, LAG	kvarh/10
165	2	L-ES	Apparent energy, low tariff	kVAh/10
167	2	L-EP-	Active energy, low tariff, outgoing	kWh/10
169	2	L-EQ-	Reactive energy, low tariff, LEAD	kvarh/10
171	2	L-EQ+LAG	Reactive energy, low tariff, incoming, LAG	kvarh/10
173	2	L-EQ+LEAD	Reactive energy, low tariff, incoming, LEAD	kvarh/10
175	2	L-EQ-LAG	Reactive energy, low tariff, outgoing, LAG	kvarh/10
177	2	L-EQ-LEAD	Reactive energy, low tariff, outgoing, LEAD	kvarh/10
179	2	L-TIMER	Energy count time, low tariff	h/10
181	2	L-EQ+P	Reactive energy, low tariff, incoming	2.00 kvarh/10
183	2	L-EQ-P	Reactive energy, low tariff, outgoing	2.00 kvarh/10
185	2	L-EPA	Active energy, low tariff, (incoming - outgoing)	2.00 kWh/10
187	2	L-EQA	Reactive energy, low tariff, (incoming + outgoing)	2.00 kvarh/10
193	2	EP_L	Active energy fraction, high tariff, incoming	kWh/(10×2 ³²)
195	2	EQ_L	Reactive energy fraction, high tariff, LAG	kvarh/(10×2 ³²)
197	2	ES_L	Apparent energy fraction, high tariff	kVAh/(10×2 ³²)
199	2	EP-_L	Active energy fraction, high tariff, outgoing	kWh/(10×2 ³²)
201	2	EQ-_L	Reactive energy fraction, high tariff, LEAD	kvarh/(10×2 ³²)
203	2	EQ+LAG_L	Reactive energy fraction, high tariff, incoming, LAG	kvarh/(10×2 ³²)
205	2	EQ+LEAD_L	Reactive energy fraction, high tariff, incoming, LEAD	kvarh/(10×2 ³²)
207	2	EQ-LAG_L	Reactive energy fraction, high tariff, outgoing, LAG	kvarh/(10×2 ³²)
209	2	EQ-LEAD_L	Reactive energy fraction, high tariff, outgoing, LEAD	kvarh/(10×2 ³²)
211	2	TIMER_L	Energy fraction count time, high tariff	seconds/1 000
213	2	EQ+P_L	Reactive energy fraction, high tariff, incoming	2.00 kvarh/(10×2 ³²)
215	2	EQ-P_L	Reactive energy fraction, high tariff, outgoing	2.00 kvarh/(10×2 ³²)
217	2	EPA_L	Active energy fraction, high tariff, (incoming - outgoing)	2.00 kWh/(10×2 ³²)
219	2	EQA_L	Reactive energy fraction, high tariff, (incoming + outgoing)	2.00 kvarh/(10×2 ³²)
225	2	L-EP_L	Active energy fraction, low tariff, incoming	kWh/(10×2 ³²)
227	2	L-EQ_L	Reactive energy fraction, low tariff, LAG	kvarh/(10×2 ³²)
229	2	L-ES_L	Apparent energy fraction, low tariff	kVAh/(10×2 ³²)
231	2	L-EP-_L	Active energy fraction, low tariff, outgoing	kWh/(10×2 ³²)
233	2	L-EQ-_L	Reactive energy fraction, low tariff, LEAD	kvarh/(10×2 ³²)
235	2	L-EQ+LAG_L	Reactive energy fraction, low tariff, incoming, LAG	kvarh/(10×2 ³²)
237	2	L-EQ+LEAD_L	Reactive energy fraction, low tariff, incoming, LEAD	kvarh/(10×2 ³²)
239	2	L-EQ-LAG_L	Reactive energy fraction, low tariff, outgoing, LAG	kvarh/(10×2 ³²)
241	2	L-EQ-LEAD_L	Reactive energy fraction, low tariff, outgoing, LEAD	kvarh/(10×2 ³²)
243	2	L-TIMER_L	Energy fraction count time, low tariff	seconds/1 000
245	2	L-EQ+P_L	Reactive energy fraction, low tariff, incoming	2.00 kvarh/(10×2 ³²)
247	2	L-EQ-P_L	Reactive energy fraction, low tariff, outgoing	2.00 kvarh/(10×2 ³²)
249	2	L-EPA_L	Active energy fraction, low tariff, (incoming - outgoing)	2.00 kWh/(10×2 ³²)
251	2	L-EQA_L	Reactive energy fraction, low tariff, (incoming + outgoing)	2.00 kvarh/(10×2 ³²)

■ AVERAGE VALUE

ADDR.	WORD	ID	PARAMETER	UNIT
257	2	I AVG	Current AVG	mA
259	2	I1 AVG	Current AVG, Line 1	mA
261	2	I2 AVG	Current AVG, Line 2	mA
263	2	I3 AVG	Current AVG, Line 3	mA
265	2	IN AVG	Neutral current AVG	mA
273	2	I AVG 1	Current AVG, History 1	mA
275	2	I1 AVG 1	Current AVG, Line 1, History 1	mA
277	2	I2 AVG 1	Current AVG, Line 2, History 1	mA
279	2	I3 AVG 1	Current AVG, Line 3, History 1	mA
281	2	IN AVG 1	Neutral current AVG, History 1	mA
289	2	I AVG 2	Current AVG, History 2	mA
291	2	I1 AVG 2	Current AVG, Line 1, History 2	mA
293	2	I2 AVG 2	Current AVG, Line 2, History 2	mA
295	2	I3 AVG 2	Current AVG, Line 3, History 2	mA
297	2	IN AVG 2	Neutral current AVG, History 2	mA
305	2	I AVG 3	Current AVG, History 3	mA
307	2	I1 AVG 3	Current AVG, Line 1, History 3	mA
309	2	I2 AVG 3	Current AVG, Line 2, History 3	mA
311	2	I3 AVG 3	Current AVG, Line 3, History 3	mA
313	2	IN AVG 3	Neutral current AVG, History 3	mA
321	2	I AVG 4	Current AVG, History 4	mA
323	2	I1 AVG 4	Current AVG, Line 1, History 4	mA
325	2	I2 AVG 4	Current AVG, Line 2, History 4	mA
327	2	I3 AVG 4	Current AVG, Line 3, History 4	mA
329	2	IN AVG 4	Neutral current AVG, History 4	mA
513	2	P AVG	Active power AVG	W
515	2	Q AVG	Reactive power AVG	var
517	2	S AVG	Apparent power AVG	VA
529	2	P AVG 1	Active power AVG, History 1	W
531	2	Q AVG 1	Reactive power AVG, History 1	var
533	2	S AVG 1	Apparent power AVG, History 1	VA
545	2	P AVG 2	Active power AVG, History 2	W
547	2	Q AVG 2	Reactive power AVG, History 2	var
549	2	S AVG 2	Apparent power AVG, History 2	VA
561	2	P AVG 3	Active power AVG, History 3	W
563	2	Q AVG 3	Reactive power AVG, History 3	var
565	2	S AVG 3	Apparent power AVG, History 3	VA
577	2	P AVG 4	Active power AVG, History 4	W
579	2	Q AVG 4	Reactive power AVG, History 4	var
581	2	S AVG 4	Apparent power AVG, History 4	VA

■ MAXIMUM / MINIMUM VALUE

ADDR.	WORD	ID	PARAMETER	UNIT
769	2	I MAX	Current MAX	mA
771	2	U MAX	Voltage MAX	V/100
773	2	P MAX	Active power MAX	W
775	2	Q MAX	Reactive power MAX	var
777	2	S MAX	Apparent power MAX	VA
779	2	PF MAX	Power factor MAX	%/100
781	2	F MAX	Frequency MAX	Hz/100
801	2	I1 MAX	Current MAX, Line 1	mA
803	2	I2 MAX	Current MAX, Line 2	mA
805	2	I3 MAX	Current MAX, Line 3	mA
807	2	IN MAX	Neutral current MAX	mA
809	2	U12 MAX	Delta voltage MAX, 1 – 2	V/100
811	2	U23 MAX	Delta voltage MAX, 2 – 3	V/100
813	2	U31 MAX	Delta voltage MAX, 3 – 1	V/100
815	2	U1N MAX	Phase voltage MAX, Phase 1	V/100
817	2	U2N MAX	Phase voltage MAX, Phase 2	V/100
819	2	U3N MAX	Phase voltage MAX, Phase 3	V/100
821	2	P1 MAX	Active power MAX, Phase 1	W
823	2	P2 MAX	Active power MAX, Phase 2	W
825	2	P3 MAX	Active power MAX, Phase 3	W
827	2	Q1 MAX	Reactive power MAX, Phase 1	var
829	2	Q2 MAX	Reactive power MAX, Phase 2	var
831	2	Q3 MAX	Reactive power MAX, Phase 3	var
833	2	S1 MAX	Apparent power MAX, Phase 1	VA
835	2	S2 MAX	Apparent power MAX, Phase 2	VA
837	2	S3 MAX	Apparent power MAX, Phase 3	VA
839	2	PF1 MAX	Power factor MAX, Phase 1	%/100
841	2	PF2 MAX	Power factor MAX, Phase 2	%/100
843	2	PF3 MAX	Power factor MAX, Phase 3	%/100
865	2	THDI1 MAX	Current total harmonic distortion MAX, Line 1	%/10
867	2	THDI2 MAX	Current total harmonic distortion MAX, Line 2	%/10
869	2	THDI3 MAX	Current total harmonic distortion MAX, Line 3	%/10
871	2	THDIN MAX	Neutral current total harmonic distortion MAX	%/10
873	2	THDU12 MAX	Delta voltage total harmonic distortion MAX, 1 – 2	%/10
875	2	THDU23 MAX	Delta voltage total harmonic distortion MAX, 2 – 3	%/10
877	2	THDU31 MAX	Delta voltage total harmonic distortion MAX, 3 – 1	%/10
879	2	THDU1N MAX	Phase voltage total harmonic distortion MAX, Phase 1	%/10
881	2	THDU2N MAX	Phase voltage total harmonic distortion MAX, Phase 2	%/10
883	2	THDU3N MAX	Phase voltage total harmonic distortion MAX, Phase 3	%/10
897	2	I MAX AVG	Current MAX AVG	mA
899	2	I1 MAX AVG	Current MAX AVG, Line 1	mA
901	2	I2 MAX AVG	Current MAX AVG, Line 2	mA
903	2	I3 MAX AVG	Current MAX AVG, Line 3	mA
905	2	IN MAX AVG	Neutral current MAX AVG	mA
907	2	P MAX AVG+	Active power MAX AVG, incoming	W
909	2	P MAX AVG–	Active power MAX AVG, outgoing	W
911	2	Q MAX AVG+	Reactive power MAX AVG, incoming	var
913	2	Q MAX AVG–	Reactive power MAX AVG, outgoing	var
915	2	S MAX AVG	Apparent power MAX AVG	VA
929	2	I MIN	Current MIN	mA
931	2	U MIN	Voltage MIN	V/100
933	2	P MIN	Active power MIN	W
935	2	Q MIN	Reactive power MIN	var
937	2	S MIN	Apparent power MIN	VA
939	2	PF MIN	Power factor MIN	%/100
941	2	F MIN	Frequency MIN	Hz/100
961	2	I1 MIN	Current MIN, Line 1	mA
963	2	I2 MIN	Current MIN, Line 2	mA
965	2	I3 MIN	Current MIN, Line 3	mA
967	2	IN MIN	Neutral current MIN	mA
969	2	U12 MIN	Delta voltage MIN, 1 – 2	V/100
971	2	U23 MIN	Delta voltage MIN, 2 – 3	V/100
973	2	U31 MIN	Delta voltage MIN, 3 – 1	V/100

ADDR.	WORD	ID	PARAMETER	UNIT
975	2	U1N MIN	Phase voltage MIN, Phase 1	V/100
977	2	U2N MIN	Phase voltage MIN, Phase 2	V/100
979	2	U3N MIN	Phase voltage MIN, Phase 3	V/100
981	2	P1 MIN	Active power MIN, Phase 1	W
983	2	P2 MIN	Active power MIN, Phase 2	W
985	2	P3 MIN	Active power MIN, Phase 3	W
987	2	Q1 MIN	Reactive power MIN, Phase 1	var
989	2	Q2 MIN	Reactive power MIN, Phase 2	var
991	2	Q3 MIN	Reactive power MIN, Phase 3	var
993	2	S1 MIN	Apparent power MIN, Phase 1	VA
995	2	S2 MIN	Apparent power MIN, Phase 2	VA
997	2	S3 MIN	Apparent power MIN, Phase 3	VA
999	2	PF1 MIN	Power factor MIN, Phase 1	%/100
1001	2	PF2 MIN	Power factor MIN, Phase 2	%/100
1003	2	PF3 MIN	Power factor MIN, Phase 3	%/100

■ **TOTAL HARMONIC DISTORTION (THD)**

ADDR.	WORD	ID	PARAMETER	UNIT
1281	2	THDI1	Current total harmonic distortion, Line 1	%/10
1283	2	THDI2	Current total harmonic distortion, Line 2	%/10
1285	2	THDI3	Current total harmonic distortion, Line 3	%/10
1287	2	THDIN	Neutral current total harmonic distortion	%/10
1289	2	THDU12	Delta voltage total harmonic distortion, 1 – 2	%/10
1291	2	THDU23	Delta voltage total harmonic distortion, 2 – 3	%/10
1293	2	THDU31	Delta voltage total harmonic distortion, 3 – 1	%/10
1295	2	THDU1N	Phase voltage total harmonic distortion, Phase 1	%/10
1297	2	THDU2N	Phase voltage total harmonic distortion, Phase 2	%/10
1299	2	THDU3N	Phase voltage total harmonic distortion, Phase 3	%/10

■ HARMONIC

ADDR.	WORD	ID	PARAMETER	UNIT
1537	1	HDI1 2	Current harmonic, Line 1, 2nd	%/10
1538	1	HDI1 3	(id) 3rd	%/10
1539	1	HDI1 4	(id) 4th	%/10
1540	1	HDI1 5	(id) 5th	%/10
1541	1	HDI1 6	(id) 6th	%/10
1542	1	HDI1 7	(id) 7th	%/10
1543	1	HDI1 8	(id) 8th	%/10
1544	1	HDI1 9	(id) 9th	%/10
1545	1	HDI1 10	(id) 10th	%/10
1546	1	HDI1 11	(id) 11th	%/10
1547	1	HDI1 12	(id) 12th	%/10
1548	1	HDI1 13	(id) 13th	%/10
1549	1	HDI1 14	(id) 14th	%/10
1550	1	HDI1 15	(id) 15th	%/10
1551	1	HDI1 16	(id) 16th	%/10
1552	1	HDI1 17	(id) 17th	%/10
1553	1	HDI1 18	(id) 18th	%/10
1554	1	HDI1 19	(id) 19th	%/10
1555	1	HDI1 20	(id) 20th	%/10
1556	1	HDI1 21	(id) 21st	%/10
1557	1	HDI1 22	(id) 22nd	%/10
1558	1	HDI1 23	(id) 23rd	%/10
1559	1	HDI1 24	(id) 24th	%/10
1560	1	HDI1 25	(id) 25th	%/10
1561	1	HDI1 26	(id) 26th	%/10
1562	1	HDI1 27	(id) 27th	%/10
1563	1	HDI1 28	(id) 28th	%/10
1564	1	HDI1 29	(id) 29th	%/10
1565	1	HDI1 30	(id) 30th	%/10
1566	1	HDI1 31	(id) 31st	%/10
1601	1	HDI2 2	Current harmonic, Line 2, 2nd	%/10
:		:	:	
1630		HDI2 31	31st	
1665	1	HDI3 2	Current harmonic, Line 3, 2nd	%/10
:		:	:	
1694		HDI3 31	31st	
1729	1	HDIN 2	Neutral current harmonic, 2nd	%/10
:		:	:	
1758		HDIN 31	31st	
1793	1	HDU12 2	Delta voltage harmonic, 1 – 2, 2nd	%/10
:		:	:	
1822		HDU12 31	31st	
1857	1	HDU23 2	Delta voltage harmonic, 2 – 3, 2nd	%/10
:		:	:	
1886		HDU23 31	31st	
1921	1	HDU31 2	Delta voltage harmonic, 3 – 1, 2nd	%/10
:		:	:	
1950		HDU31 31	31st	
1985	1	HDU1N 2	Phase voltage harmonic, Phase 1, 2nd	%/10
:		:	:	
2014		HDU1N 31	31st	
2049	1	HDU2N 2	Phase voltage harmonic, Phase 2, 2nd	%/10
:		:	:	
2078		HDU2N 31	31st	
2113	1	HDU3N 2	Phase voltage harmonic, Phase 3, 2nd	%/10
:		:	:	
2142		HDU3N 31	31st	

■ DISCRETE I/O DQ DI

ADDR.	WORD	PARAMETER
3073	1	Discrete input status
3105	1	Discrete output 1 The discrete output status can be changed by writing at this address from the host if no function is assigned.
3106	1	Discrete output 2 The discrete output status can be changed by writing at this address from the host if no function is assigned.
3107	1	Discrete output 3 The discrete output status can be changed by writing at this address from the host if no function is assigned.
3108	1	Discrete output 4 The discrete output status can be changed by writing at this address from the host if no function is assigned.

■ ANALOG OUTPUT AQ

ADDR.	WORD	PARAMETER	UNIT
3137	1	Analog output 1 Reads the present analog output value. The output value can be changed by writing at this address from the host if no function is assigned.	mA/100 or mV
3138	1	Analog output 2 Reads the present analog output value. The output value can be changed by writing at this address from the host if no function is assigned.	mA/100 or mV
3139	1	Analog output 3 Reads the present analog output value. The output value can be changed by writing at this address from the host if no function is assigned.	mA/100 or mV
3140	1	Analog output 4 Reads the present analog output value. The output value can be changed by writing at this address from the host if no function is assigned.	mA/100 or mV

■ ERROR, ALARM

ADDR.	WORD	PARAMETER																	
8001	1	Overload input Bit assignment as shown below. Bit 15 14 13 12 11 10 9 8 7 6 5 4 3 2 1 0 <table border="1" style="width:100%; text-align:center;"> <tr> <td></td><td></td><td></td><td>F</td><td></td><td>U31</td><td>U23</td><td>U12</td><td></td><td>U3N</td><td>U2N</td><td>U1N</td><td></td><td>I3</td><td>I2</td><td>I1</td> </tr> </table> '1' is placed when the respective inputs are overload.				F		U31	U23	U12		U3N	U2N	U1N		I3	I2	I1	
			F		U31	U23	U12		U3N	U2N	U1N		I3	I2	I1				
8002	1	Number of alarm trips Shows number of alarms presently triggered.																	
8003	1	System error Bit assignment as shown below. Bit 15 14 13 12 11 10 9 8 7 6 5 4 3 2 1 0 <table border="1" style="width:100%; text-align:center;"> <tr> <td></td><td></td><td></td><td></td><td></td><td></td><td></td><td></td><td></td><td></td><td>STAT</td><td>AVG</td><td>ENE</td><td>SET</td><td>FDT</td><td>PRG</td> </tr> </table> PGR : Control software error FDT : Factory calibration data error SET : User setting data error ENE : Energy data error AVG : Average data error STAT : Maximum / minimum data error '1' is placed when the respective errors are detected. All measuring operations stop while one or more system errors are detected.											STAT	AVG	ENE	SET	FDT	PRG	
										STAT	AVG	ENE	SET	FDT	PRG				
8004	1	Reserved																	
8005	1	I1 thr. I3 - Current : Alarm Bit assignment as shown below. Bit 15 14 13 12 11 10 9 8 7 6 5 4 3 2 1 0 <table border="1" style="width:100%; text-align:center;"> <tr> <td></td><td></td><td></td><td></td><td></td><td></td><td></td><td></td><td></td><td></td><td>I3 HI</td><td>I2 HI</td><td>I1 HI</td><td></td><td>I3 LO</td><td>I2 LO</td><td>I1 LO</td> </tr> </table> '1' is placed when the respective values are out of the predetermined ranges. '0' in all bits means that no alarm is tripped.											I3 HI	I2 HI	I1 HI		I3 LO	I2 LO	I1 LO
										I3 HI	I2 HI	I1 HI		I3 LO	I2 LO	I1 LO			
8006	1	IN - Neutral current : Alarm Bit assignment as shown below. Bit 15 14 13 12 11 10 9 8 7 6 5 4 3 2 1 0 <table border="1" style="width:100%; text-align:center;"> <tr> <td></td><td></td><td></td><td></td><td></td><td></td><td></td><td></td><td></td><td></td><td></td><td>IN HI</td><td></td><td></td><td></td><td>IN LO</td> </tr> </table> '1' is placed when the value is out of the predetermined range. '0' in all bits means that no alarm is tripped.												IN HI				IN LO	
											IN HI				IN LO				
8007	1	U12 thr. U31 - Delta voltage : Alarm Bit assignment as shown below. Bit 15 14 13 12 11 10 9 8 7 6 5 4 3 2 1 0 <table border="1" style="width:100%; text-align:center;"> <tr> <td></td><td></td><td></td><td></td><td></td><td></td><td></td><td></td><td></td><td></td><td>U31 HI</td><td>U31 HI</td><td>U31 HI</td><td></td><td>U31 LO</td><td>U31 LO</td><td>U31 LO</td> </tr> </table> '1' is placed when the respective values are out of the predetermined ranges. '0' in all bits means that no alarm is tripped.											U31 HI	U31 HI	U31 HI		U31 LO	U31 LO	U31 LO
										U31 HI	U31 HI	U31 HI		U31 LO	U31 LO	U31 LO			
8008	1	U1N thr. U3N - Phase voltage : Alarm Bit assignment as shown below. Bit 15 14 13 12 11 10 9 8 7 6 5 4 3 2 1 0 <table border="1" style="width:100%; text-align:center;"> <tr> <td></td><td></td><td></td><td></td><td></td><td></td><td></td><td></td><td></td><td></td><td>U3N HI</td><td>U2N HI</td><td>U1N HI</td><td></td><td>U3N LO</td><td>U2N LO</td><td>U1N LO</td> </tr> </table> '1' is placed when the respective values are out of the predetermined ranges. '0' in all bits means that no alarm is tripped.											U3N HI	U2N HI	U1N HI		U3N LO	U2N LO	U1N LO
										U3N HI	U2N HI	U1N HI		U3N LO	U2N LO	U1N LO			
8009	1	P - Active power : Alarm Bit assignment as shown below. Bit 15 14 13 12 11 10 9 8 7 6 5 4 3 2 1 0 <table border="1" style="width:100%; text-align:center;"> <tr> <td></td><td></td><td></td><td></td><td></td><td></td><td></td><td></td><td></td><td></td><td></td><td>P HI</td><td></td><td></td><td></td><td>P LO</td> </tr> </table> '1' is placed when the value is out of the predetermined range. '0' in all bits means that no alarm is tripped.												P HI				P LO	
											P HI				P LO				

ADDR.	WORD	PARAMETER																																	
8010	1	<p>Q - Reactive power : Alarm Bit assignment as shown below.</p> <p>Bit 15 14 13 12 11 10 9 8 7 6 5 4 3 2 1 0</p> <table border="1" style="width: 100%; text-align: center;"> <tr> <td style="width: 5%;"> </td><td style="width: 5%;"> </td><td style="width: 5%;"> </td><td style="width: 5%;"> </td><td style="width: 5%;"> </td><td style="width: 5%;"> </td><td style="width: 5%;"> </td><td style="width: 5%;"> </td><td style="width: 5%;"> </td><td style="width: 5%;"> </td><td style="width: 5%;"> </td><td style="width: 5%;"> </td><td style="width: 5%;"> </td><td style="width: 5%;"> </td><td style="width: 5%;"> </td><td style="width: 5%;"> </td> </tr> <tr> <td> </td><td> </td><td> </td><td> </td><td> </td><td> </td><td> </td><td> </td><td> </td><td> </td><td> </td><td>Q HI</td><td> </td><td> </td><td> </td><td>Q LO</td> </tr> </table> <p>'1' is placed when the value is out of the predetermined range. '0' in all bits means that no alarm is tripped.</p>																												Q HI				Q LO	
											Q HI				Q LO																				
8011	1	<p>S - Apparent power : Alarm Bit assignment as shown below.</p> <p>Bit 15 14 13 12 11 10 9 8 7 6 5 4 3 2 1 0</p> <table border="1" style="width: 100%; text-align: center;"> <tr> <td style="width: 5%;"> </td><td style="width: 5%;"> </td><td style="width: 5%;"> </td><td style="width: 5%;"> </td><td style="width: 5%;"> </td><td style="width: 5%;"> </td><td style="width: 5%;"> </td><td style="width: 5%;"> </td><td style="width: 5%;"> </td><td style="width: 5%;"> </td><td style="width: 5%;"> </td><td style="width: 5%;"> </td><td style="width: 5%;"> </td><td style="width: 5%;"> </td><td style="width: 5%;"> </td><td style="width: 5%;"> </td> </tr> <tr> <td> </td><td> </td><td> </td><td> </td><td> </td><td> </td><td> </td><td> </td><td> </td><td> </td><td> </td><td>S HI</td><td> </td><td> </td><td> </td><td>S LO</td> </tr> </table> <p>'1' is placed when the value is out of the predetermined range. '0' in all bits means that no alarm is tripped.</p>																												S HI				S LO	
											S HI				S LO																				
8012	1	<p>PF - Power factor : Alarm Bit assignment as shown below.</p> <p>Bit 15 14 13 12 11 10 9 8 7 6 5 4 3 2 1 0</p> <table border="1" style="width: 100%; text-align: center;"> <tr> <td style="width: 5%;"> </td><td style="width: 5%;"> </td><td style="width: 5%;"> </td><td style="width: 5%;"> </td><td style="width: 5%;"> </td><td style="width: 5%;"> </td><td style="width: 5%;"> </td><td style="width: 5%;"> </td><td style="width: 5%;"> </td><td style="width: 5%;"> </td><td style="width: 5%;"> </td><td style="width: 5%;"> </td><td style="width: 5%;"> </td><td style="width: 5%;"> </td><td style="width: 5%;"> </td><td style="width: 5%;"> </td> </tr> <tr> <td> </td><td> </td><td> </td><td> </td><td> </td><td> </td><td> </td><td> </td><td> </td><td> </td><td> </td><td>PF HI</td><td> </td><td> </td><td> </td><td>PF LO</td> </tr> </table> <p>'1' is placed when the value is out of the predetermined range. '0' in all bits means that no alarm is tripped.</p>																												PF HI				PF LO	
											PF HI				PF LO																				
8013	1	<p>F - Frequency : Alarm Bit assignment as shown below.</p> <p>Bit 15 14 13 12 11 10 9 8 7 6 5 4 3 2 1 0</p> <table border="1" style="width: 100%; text-align: center;"> <tr> <td style="width: 5%;"> </td><td style="width: 5%;"> </td><td style="width: 5%;"> </td><td style="width: 5%;"> </td><td style="width: 5%;"> </td><td style="width: 5%;"> </td><td style="width: 5%;"> </td><td style="width: 5%;"> </td><td style="width: 5%;"> </td><td style="width: 5%;"> </td><td style="width: 5%;"> </td><td style="width: 5%;"> </td><td style="width: 5%;"> </td><td style="width: 5%;"> </td><td style="width: 5%;"> </td><td style="width: 5%;"> </td> </tr> <tr> <td> </td><td> </td><td> </td><td> </td><td> </td><td> </td><td> </td><td> </td><td> </td><td> </td><td> </td><td>F HI</td><td> </td><td> </td><td> </td><td>F LO</td> </tr> </table> <p>'1' is placed when the value is out of the predetermined range. '0' in all bits means that no alarm is tripped.</p>																												F HI				F LO	
											F HI				F LO																				
8014	1	<p>I1 AVG thr. I3 AVG - Average (demand) current : Alarm Bit assignment as shown below.</p> <p>Bit 15 14 13 12 11 10 9 8 7 6 5 4 3 2 1 0</p> <table border="1" style="width: 100%; text-align: center;"> <tr> <td style="width: 5%;"> </td><td style="width: 5%;"> </td><td style="width: 5%;"> </td><td style="width: 5%;"> </td><td style="width: 5%;"> </td><td style="width: 5%;"> </td><td style="width: 5%;"> </td><td style="width: 5%;"> </td><td style="width: 5%;"> </td><td style="width: 5%;"> </td><td style="width: 5%;"> </td><td style="width: 5%;"> </td><td style="width: 5%;"> </td><td style="width: 5%;"> </td><td style="width: 5%;"> </td><td style="width: 5%;"> </td> </tr> <tr> <td> </td><td> </td><td> </td><td> </td><td> </td><td> </td><td> </td><td> </td><td> </td><td> </td><td>I3 AVG HI</td><td>I2 AVG HI</td><td>I1 AVG HI</td><td> </td><td>I3 AVG LO</td><td>I2 AVG LO</td><td>I1 AVG LO</td> </tr> </table> <p>'1' is placed when the respective values are out of the predetermined ranges. '0' in all bits means that no alarm is tripped.</p>																											I3 AVG HI	I2 AVG HI	I1 AVG HI		I3 AVG LO	I2 AVG LO	I1 AVG LO
										I3 AVG HI	I2 AVG HI	I1 AVG HI		I3 AVG LO	I2 AVG LO	I1 AVG LO																			
8015	1	<p>IN AVG - Average (demand) neutral current : Alarm Bit assignment as shown below.</p> <p>Bit 15 14 13 12 11 10 9 8 7 6 5 4 3 2 1 0</p> <table border="1" style="width: 100%; text-align: center;"> <tr> <td style="width: 5%;"> </td><td style="width: 5%;"> </td><td style="width: 5%;"> </td><td style="width: 5%;"> </td><td style="width: 5%;"> </td><td style="width: 5%;"> </td><td style="width: 5%;"> </td><td style="width: 5%;"> </td><td style="width: 5%;"> </td><td style="width: 5%;"> </td><td style="width: 5%;"> </td><td style="width: 5%;"> </td><td style="width: 5%;"> </td><td style="width: 5%;"> </td><td style="width: 5%;"> </td><td style="width: 5%;"> </td> </tr> <tr> <td> </td><td> </td><td> </td><td> </td><td> </td><td> </td><td> </td><td> </td><td> </td><td> </td><td> </td><td> </td><td> </td><td> </td><td>IN AVG HI</td><td>IN AVG LO</td> </tr> </table> <p>'1' is placed when the value is out of the predetermined range. '0' in all bits means that no alarm is tripped.</p>																															IN AVG HI	IN AVG LO	
														IN AVG HI	IN AVG LO																				
8016	1	<p>P AVG - Average (demand) active power : Alarm Bit assignment as shown below.</p> <p>Bit 15 14 13 12 11 10 9 8 7 6 5 4 3 2 1 0</p> <table border="1" style="width: 100%; text-align: center;"> <tr> <td style="width: 5%;"> </td><td style="width: 5%;"> </td><td style="width: 5%;"> </td><td style="width: 5%;"> </td><td style="width: 5%;"> </td><td style="width: 5%;"> </td><td style="width: 5%;"> </td><td style="width: 5%;"> </td><td style="width: 5%;"> </td><td style="width: 5%;"> </td><td style="width: 5%;"> </td><td style="width: 5%;"> </td><td style="width: 5%;"> </td><td style="width: 5%;"> </td><td style="width: 5%;"> </td><td style="width: 5%;"> </td> </tr> <tr> <td> </td><td> </td><td> </td><td> </td><td> </td><td> </td><td> </td><td> </td><td> </td><td> </td><td> </td><td> </td><td> </td><td> </td><td>P AVG HI</td><td>P AVG LO</td> </tr> </table> <p>'1' is placed when the value is out of the predetermined range. '0' in all bits means that no alarm is tripped.</p>																															P AVG HI	P AVG LO	
														P AVG HI	P AVG LO																				
8017	1	<p>Q AVG - Average (demand) reactive power : Alarm Bit assignment as shown below.</p> <p>Bit 15 14 13 12 11 10 9 8 7 6 5 4 3 2 1 0</p> <table border="1" style="width: 100%; text-align: center;"> <tr> <td style="width: 5%;"> </td><td style="width: 5%;"> </td><td style="width: 5%;"> </td><td style="width: 5%;"> </td><td style="width: 5%;"> </td><td style="width: 5%;"> </td><td style="width: 5%;"> </td><td style="width: 5%;"> </td><td style="width: 5%;"> </td><td style="width: 5%;"> </td><td style="width: 5%;"> </td><td style="width: 5%;"> </td><td style="width: 5%;"> </td><td style="width: 5%;"> </td><td style="width: 5%;"> </td><td style="width: 5%;"> </td> </tr> <tr> <td> </td><td> </td><td> </td><td> </td><td> </td><td> </td><td> </td><td> </td><td> </td><td> </td><td> </td><td> </td><td> </td><td> </td><td>Q AVG HI</td><td>Q AVG LO</td> </tr> </table> <p>'1' is placed when the value is out of the predetermined range. '0' in all bits means that no alarm is tripped.</p>																															Q AVG HI	Q AVG LO	
														Q AVG HI	Q AVG LO																				
8018	1	<p>S AVG - Average (demand) apparent power : Alarm Bit assignment as shown below.</p> <p>Bit 15 14 13 12 11 10 9 8 7 6 5 4 3 2 1 0</p> <table border="1" style="width: 100%; text-align: center;"> <tr> <td style="width: 5%;"> </td><td style="width: 5%;"> </td><td style="width: 5%;"> </td><td style="width: 5%;"> </td><td style="width: 5%;"> </td><td style="width: 5%;"> </td><td style="width: 5%;"> </td><td style="width: 5%;"> </td><td style="width: 5%;"> </td><td style="width: 5%;"> </td><td style="width: 5%;"> </td><td style="width: 5%;"> </td><td style="width: 5%;"> </td><td style="width: 5%;"> </td><td style="width: 5%;"> </td><td style="width: 5%;"> </td> </tr> <tr> <td> </td><td> </td><td> </td><td> </td><td> </td><td> </td><td> </td><td> </td><td> </td><td> </td><td> </td><td> </td><td> </td><td> </td><td>S AVG HI</td><td>S AVG LO</td> </tr> </table> <p>'1' is placed when the value is out of the predetermined range. '0' in all bits means that no alarm is tripped.</p>																															S AVG HI	S AVG LO	
														S AVG HI	S AVG LO																				

ADDR.	WORD	PARAMETER																																
8019	1	<p>THDI1 thr. THDI3 - Current total harmonic distortion : Alarm Bit assignment as shown below.</p> <p>Bit 15 14 13 12 11 10 9 8 7 6 5 4 3 2 1 0</p> <table border="1" style="width: 100%; text-align: center;"> <tr> <td style="width: 5%;"> </td><td style="width: 5%;"> </td><td style="width: 5%;"> </td><td style="width: 5%;"> </td><td style="width: 5%;"> </td><td style="width: 5%;"> </td><td style="width: 5%;"> </td><td style="width: 5%;"> </td><td style="width: 5%;"> </td><td style="width: 5%;"> </td><td style="width: 5%;"> </td><td style="width: 5%;"> </td><td style="width: 5%;"> </td><td style="width: 5%;"> </td><td style="width: 5%;"> </td><td style="width: 5%;"> </td> </tr> <tr> <td></td><td></td><td></td><td></td><td></td><td></td><td></td><td></td><td></td><td>THD I3 HI</td><td>THD I2 HI</td><td>THD I1 HI</td><td></td><td>THD I3 LO</td><td>THD I2 LO</td><td>THD I1 LO</td> </tr> </table> <p>'1' is placed when the respective values are out of the predetermined ranges. '0' in all bits means that no alarm is tripped.</p>																										THD I3 HI	THD I2 HI	THD I1 HI		THD I3 LO	THD I2 LO	THD I1 LO
									THD I3 HI	THD I2 HI	THD I1 HI		THD I3 LO	THD I2 LO	THD I1 LO																			
8020	1	<p>THDIN - Neutral current total harmonic distortion : Alarm Bit assignment as shown below.</p> <p>Bit 15 14 13 12 11 10 9 8 7 6 5 4 3 2 1 0</p> <table border="1" style="width: 100%; text-align: center;"> <tr> <td style="width: 5%;"> </td><td style="width: 5%;"> </td><td style="width: 5%;"> </td><td style="width: 5%;"> </td><td style="width: 5%;"> </td><td style="width: 5%;"> </td><td style="width: 5%;"> </td><td style="width: 5%;"> </td><td style="width: 5%;"> </td><td style="width: 5%;"> </td><td style="width: 5%;"> </td><td style="width: 5%;"> </td><td style="width: 5%;"> </td><td style="width: 5%;"> </td><td style="width: 5%;"> </td><td style="width: 5%;"> </td> </tr> <tr> <td></td><td></td><td></td><td></td><td></td><td></td><td></td><td></td><td></td><td></td><td></td><td>THD IN HI</td><td></td><td></td><td></td><td>THD IN LO</td> </tr> </table> <p>'1' is placed when the value is out of the predetermined range. '0' in all bits means that no alarm is tripped.</p>																												THD IN HI				THD IN LO
											THD IN HI				THD IN LO																			
8021	1	<p>THDU12 thr. THDU31 - Delta voltage total harmonic distortion : Alarm Bit assignment as shown below.</p> <p>Bit 15 14 13 12 11 10 9 8 7 6 5 4 3 2 1 0</p> <table border="1" style="width: 100%; text-align: center;"> <tr> <td style="width: 5%;"> </td><td style="width: 5%;"> </td><td style="width: 5%;"> </td><td style="width: 5%;"> </td><td style="width: 5%;"> </td><td style="width: 5%;"> </td><td style="width: 5%;"> </td><td style="width: 5%;"> </td><td style="width: 5%;"> </td><td style="width: 5%;"> </td><td style="width: 5%;"> </td><td style="width: 5%;"> </td><td style="width: 5%;"> </td><td style="width: 5%;"> </td><td style="width: 5%;"> </td><td style="width: 5%;"> </td> </tr> <tr> <td></td><td></td><td></td><td></td><td></td><td></td><td></td><td></td><td></td><td>THD U31 HI</td><td>THD U23 HI</td><td>THD U12 HI</td><td></td><td>THD U31 LO</td><td>THD U23 LO</td><td>THD U12 LO</td> </tr> </table> <p>'1' is placed when the respective values are out of the predetermined ranges. '0' in all bits means that no alarm is tripped.</p>																										THD U31 HI	THD U23 HI	THD U12 HI		THD U31 LO	THD U23 LO	THD U12 LO
									THD U31 HI	THD U23 HI	THD U12 HI		THD U31 LO	THD U23 LO	THD U12 LO																			
8022	1	<p>THDU1N thr. THDU3N - Phase voltage total harmonic distortion : Alarm Bit assignment as shown below.</p> <p>Bit 15 14 13 12 11 10 9 8 7 6 5 4 3 2 1 0</p> <table border="1" style="width: 100%; text-align: center;"> <tr> <td style="width: 5%;"> </td><td style="width: 5%;"> </td><td style="width: 5%;"> </td><td style="width: 5%;"> </td><td style="width: 5%;"> </td><td style="width: 5%;"> </td><td style="width: 5%;"> </td><td style="width: 5%;"> </td><td style="width: 5%;"> </td><td style="width: 5%;"> </td><td style="width: 5%;"> </td><td style="width: 5%;"> </td><td style="width: 5%;"> </td><td style="width: 5%;"> </td><td style="width: 5%;"> </td><td style="width: 5%;"> </td> </tr> <tr> <td></td><td></td><td></td><td></td><td></td><td></td><td></td><td></td><td></td><td>THD U3N HI</td><td>THD U2N HI</td><td>THD U1N HI</td><td></td><td>THD U3N LO</td><td>THD U2N LO</td><td>THD U1N LO</td> </tr> </table> <p>'1' is placed when the respective values are out of the predetermined ranges. '0' in all bits means that no alarm is tripped.</p>																										THD U3N HI	THD U2N HI	THD U1N HI		THD U3N LO	THD U2N LO	THD U1N LO
									THD U3N HI	THD U2N HI	THD U1N HI		THD U3N LO	THD U2N LO	THD U1N LO																			
8023	1	<p>UT12 thr. UT31 - Phase angle between phase voltages : Alarm 2.00 Bit assignment as shown below.</p> <p>Bit 15 14 13 12 11 10 9 8 7 6 5 4 3 2 1 0</p> <table border="1" style="width: 100%; text-align: center;"> <tr> <td style="width: 5%;"> </td><td style="width: 5%;"> </td><td style="width: 5%;"> </td><td style="width: 5%;"> </td><td style="width: 5%;"> </td><td style="width: 5%;"> </td><td style="width: 5%;"> </td><td style="width: 5%;"> </td><td style="width: 5%;"> </td><td style="width: 5%;"> </td><td style="width: 5%;"> </td><td style="width: 5%;"> </td><td style="width: 5%;"> </td><td style="width: 5%;"> </td><td style="width: 5%;"> </td><td style="width: 5%;"> </td> </tr> <tr> <td></td><td></td><td></td><td></td><td></td><td></td><td></td><td></td><td></td><td>UT31 HI</td><td>UT23 HI</td><td>UT12 HI</td><td></td><td>UT31 LO</td><td>UT23 LO</td><td>UT12 LO</td> </tr> </table> <p>'1' is placed when the respective values are out of the predetermined ranges. '0' in all bits means that no alarm is tripped.</p>																										UT31 HI	UT23 HI	UT12 HI		UT31 LO	UT23 LO	UT12 LO
									UT31 HI	UT23 HI	UT12 HI		UT31 LO	UT23 LO	UT12 LO																			

ALARM HISTORY

Latest alarm data is updated whenever a new alarm is tripped, and the second latest one is shifted to 'History 1,' the third one to 'History 2,' and so forth.

ADDR.	WORD	PARAMETER
8129	1	Latest alarm trip, parameter number 0 : I1 thr. I3 - Current 1 : IN - Neutral current 2 : U12 thr. U31 - Delta voltage 3 : U1N thr. U3N - Phase voltage 4 : P - Active power 5 : Q - Reactive power 6 : S - Apparent power 7 : PF - Power factor 8 : F - Frequency 9 : I1 AVG thr. I3 AVG - Average (demand) current 10 : IN AVG - Average (demand) neutral current 11 : P AVG - Average (demand) active power 12 : Q AVG - Average (demand) reactive power 13 : S AVG - Average (demand) apparent power 14 : THDI1 thr. THDI3 - Current total harmonic distortion 15 : THDIN - Neutral current total harmonic distortion 16 : THDU12 thr. THDU31 - Delta voltage total harmonic distortion 17 : THDU1N thr. THDU3N - Phase voltage total harmonic distortion 18 : UT12 thr. UT31 - Phase angle between phase voltages total harmonic distortion 2.00
8130	1	Latest alarm trip, parameter point Shows which point triggered the latest alarm. Bit assignments are identical to those for 'Alarm,' register address starting from 8005. For example, '0' at 'parameter number' (8128) and '1' at Bit 0 of this register address means that I1 value is lower than the low setpoint, triggering the alarm. If another point within the same parameter number goes into alarm after one (e.g. if I2 value goes above the high setpoint while I1 thr. I3 alarm is triggered), the second trip is not recorded in the history.
8131	2	Latest alarm trip, value Shows the data value at the moment of alarm.
8133	1	Alarm trip, parameter number, History 1
8134	1	Alarm trip, parameter point, History 1
8135	2	Alarm trip, value, History 1
8137	1	Alarm trip, parameter number, History 2
8138	1	Alarm trip, parameter point, History 2
8139	2	Alarm trip, value, History 2
8141	1	Alarm trip, parameter number, History 3
8142	1	Alarm trip, parameter point, History 3
8143	2	Alarm trip, value, History 3
8145	1	Alarm trip, parameter number, History 4
8146	1	Alarm trip, parameter point, History 4
8147	2	Alarm trip, value, History 4
8149	1	Alarm trip, parameter number, History 5
8150	1	Alarm trip, parameter point, History 5
8151	2	Alarm trip, value, History 5
8153	1	Alarm trip, parameter number, History 6
8154	1	Alarm trip, parameter point, History 6
8155	2	Alarm trip, value, History 6
8157	1	Alarm trip, parameter number, History 7
8158	1	Alarm trip, parameter point, History 7
8159	2	Alarm trip, value, History 7
8161	1	Alarm trip, parameter number, History 8
8162	1	Alarm trip, parameter point, History 8
8163	2	Alarm trip, value, History 8
8165	1	Alarm trip, parameter number, History 9
8166	1	Alarm trip, parameter point, History 9
8167	2	Alarm trip, value, History 9

■ DIAGNOSTICS

ADDR.	WORD	PARAMETER	UNIT
9201	2	Received Modbus frames	times
9203	2	Discarded Modbus frames	times
9205	2	Responded Modbus frames	times
9207	2	Responded Modbus Exception (error) frames	times
9209	2	Detected Modbus Framing Error frames	times
9211	2	Detected Modbus Overrun Error frames	times
9213	2	Detected Modbus Parity Error frames	times
9215	2	Detected Modbus CRC Error frames	times
9217	2	Processing delays	times
9219	2	Processing delay sequence number	No.

■ DEVICE INFORMATION

ADDR.	WORD	PARAMETER
9601	1	Device ID 5301 : 53U
9602	1	Device Version No. Version No. = (No. × 100). e.g. Version 1.00 = 100
9603 9604 9605 9606	4	Serial No. Upper digit: 2nd character Lower digit: 1st character Upper digit: 4th character Lower digit: 3rd character Upper digit: 6th character Lower digit: 5th character Upper digit: 8th character Lower digit: 7th character
9607 9608 9609 9610 9611 9612 9613 9614	8	Tag No. Upper digit: 2nd character Lower digit: 1st character Upper digit: 4th character Lower digit: 3rd character Upper digit: 6th character Lower digit: 5th character Upper digit: 8th character Lower digit: 7th character Upper digit: 10th character Lower digit: 9th character Upper digit: 12th character Lower digit: 11th character Upper digit: 14th character Lower digit: 13th character Upper digit: 16th character Lower digit: 15th character This register can be written in.
9623	1	Extension function 2.00 An addition of the following numbers are read out to identify the external interface type. 0001 : Analog output 4 – 20mA DC 0002 : RS-485 (Modbus RTU) 0004 : Analog output 1 – 5V DC 0008 : Contact output 110V DC
9624	1	Numbers of Di 2.00 0 : None 1 : 1 point
9625	1	Numbers of Do 2.00 0 : None 1 thr. 4 : 1 thr. 4 points
9626	1	Numbers of Ao 2.00 0 : None 1 thr. 4 : 1 thr. 4 points

OPERATION FLOWCHART

■ DISPLAY

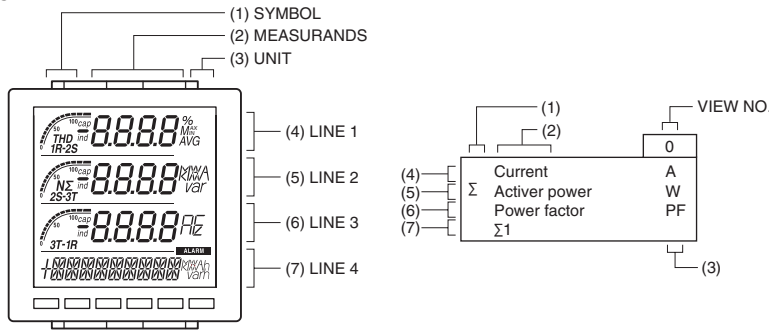

■ HOW TO SWITCH THE DISPLAY VIEWS

Pressing one of Σ \leftarrow \rightarrow IU \rightarrow PQS ∇ PF THD \blacktriangle buttons switches the view to the one of top among those assigned to the respective button. Pressing the same button continuously switches it to more selections in turn.

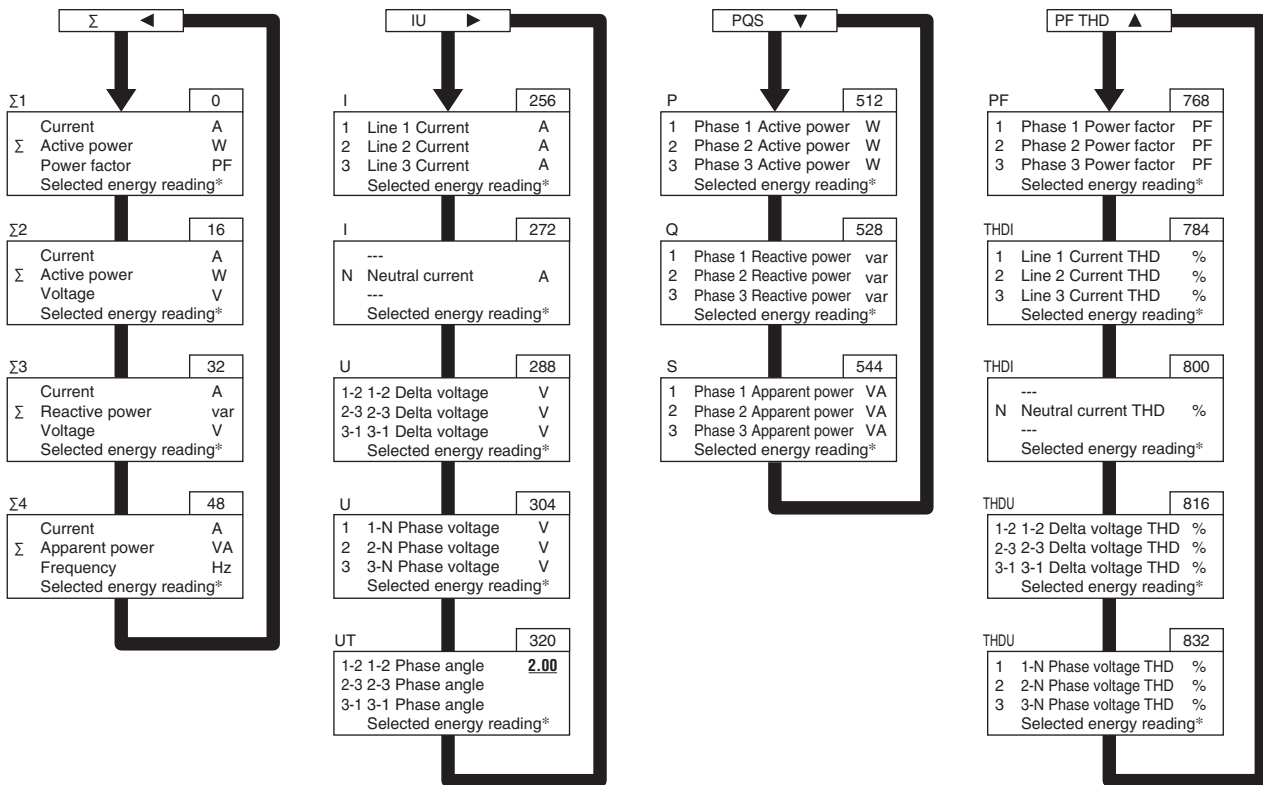

Σ 1 thr. Σ 4 views in the above figure shows the factory setting. These combinations can be changed.

MAX ENTER button switches the presently displayed view to its extension views if any.

Pressing the same button continuously switches it to more selections in turn.

Basic and extension views are all listed in the table in the following page.

[Example] Pressing **MAX ENTER** button on the view No. 768 (power factor) switches it to extension views as below.

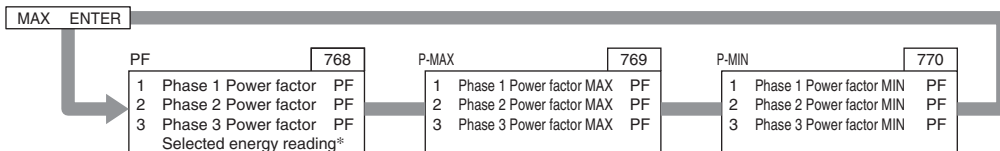

*Selected with **E PRG ESCAPE** button.

Basic and extension view parameters

BASIC PARAMETER	EXTENSION								
	MAX	MIN	AVE	AVE HIST1	AVE HIST2	AVE HIST3	AVE HIST4	MAX AVE	MAX AVE (out)
Not assigned									
Current	X	X	X	X	X	X	X	X	
Voltage	X	X	X						
Active power	X	X	X	X	X	X	X	X	X
Reactive power	X	X	X	X	X	X	X	X	X
Apparent power	X	X	X	X	X	X	X	X	
Power factor	X	X							
Frequency	X	X							
Current, Line 1	X	X	X	X	X	X	X	X	
Current, Line 2	X	X	X	X	X	X	X	X	
Current, Line 3	X	X	X	X	X	X	X	X	
Neutral current	X	X	X	X	X	X	X	X	
Delta voltage, 1 – 2	X	X							
Delta voltage, 2 – 3	X	X							
Delta voltage, 3 – 1	X	X							
Phase voltage, Phase 1	X	X							
Phase voltage, Phase 2	X	X							
Phase voltage, Phase 3	X	X							
Active power, Phase 1	X	X							
Active power, Phase 2	X	X							
Active power, Phase 3	X	X							
Reactive power, Phase 1	X	X							
Reactive power, Phase 2	X	X							
Reactive power, Phase 3	X	X							
Apparent power, Phase 1	X	X							
Apparent power, Phase 2	X	X							
Apparent power, Phase 3	X	X							
Power factor, Phase 1	X	X							
Power factor, Phase 2	X	X							
Power factor, Phase 3	X	X							
THD, Current, Line 1	X								
THD, Current, Line 2	X								
THD, Current, Line 3	X								
THD, Neutral current	X								
THD, Delta voltage, 1 – 2	X								
THD, Delta voltage, 2 – 3	X								
THD, Delta voltage, 3 – 1	X								
THD, Phase voltage, Phase 1	X								
THD, Phase voltage, Phase 2	X								
THD, Phase voltage, Phase 3	X								
Phase angle between phase voltages, 1 – 2									
Phase angle between phase voltages, 2 – 3									
Phase angle between phase voltages, 3 – 1									
Active energy, high tariff, incoming									
Reactive energy, high tariff, LAG									
Apparent energy, high tariff									
Active energy, high tariff, outgoing									
Reactive energy, high tariff, LEAD									
Reactive energy, high tariff, incoming/LAG									
Reactive energy, high tariff, incoming/LEAD									
Reactive energy, high tariff, outgoing/LAG									
Reactive energy, high tariff, outgoing/LEAD									
Energy count time, high tariff									
Active energy, low tariff, incoming									
Reactive energy, low tariff, LAG									
Apparent energy, low tariff									
Active energy, low tariff, outgoing									
Reactive energy, low tariff, LEAD									
Reactive energy, low tariff, incoming/LAG									
Reactive energy, low tariff, incoming/LEAD									
Reactive energy, low tariff, outgoing/LAG									
Reactive energy, low tariff, outgoing/LEAD									
Energy count time, low tariff									

HARMONIC

Hold down both buttons for 1 second or more to switch from various setting mode to the harmonics.
 Press triangle buttons to switch the views.

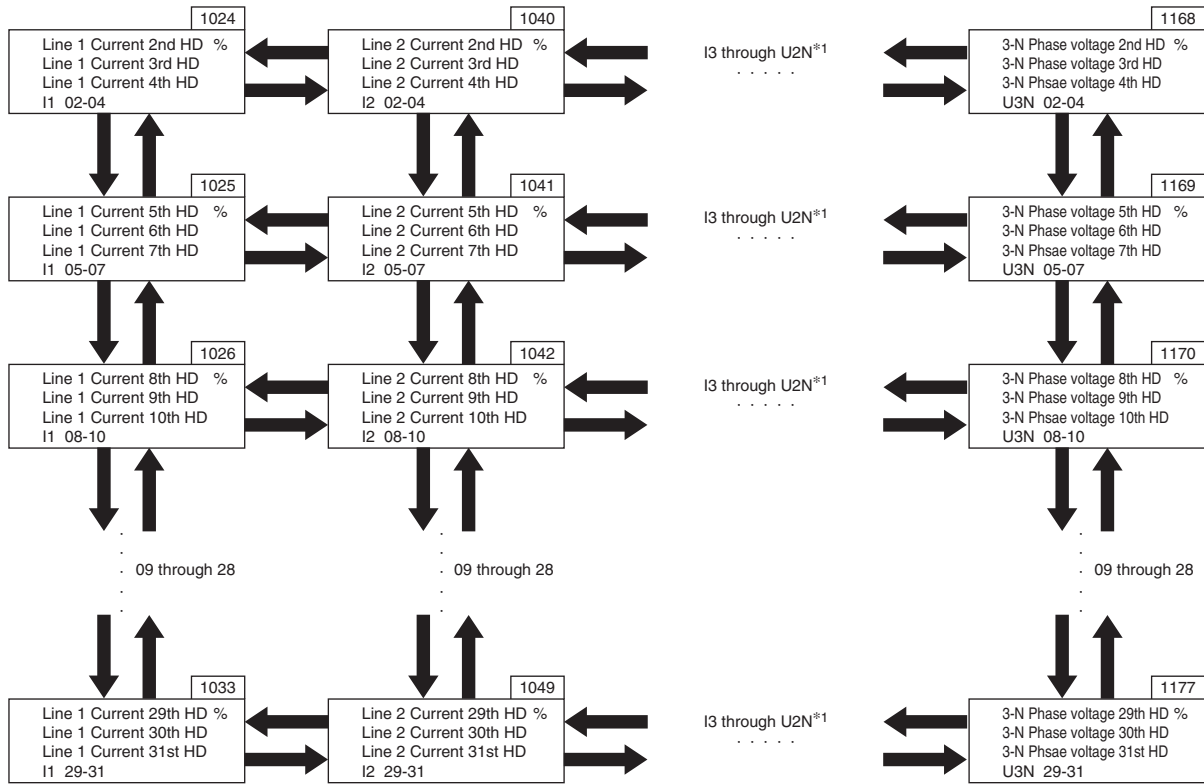

- *1. I3 : Line 3 Current HD
- IN : Neutral current HD
- U12 : 1-2 Delta voltage HD
- U23 : 2-3 Delta voltage HD
- U31 : 3-1 Delta voltage HD
- U1N : 1-N Phase voltage HD
- U2N : 2-N Phase voltage HD

SHORTCUT MENU 2.00

Hold down button until the 4th line is switched to the shortcut menu.
 Resetting alarm trip and other operations are swiftly executed using this menu.
 Press button one or more times to scroll the menu.
 Press button to execute a menu command.
 Press any other button to exit the shortcut menu.

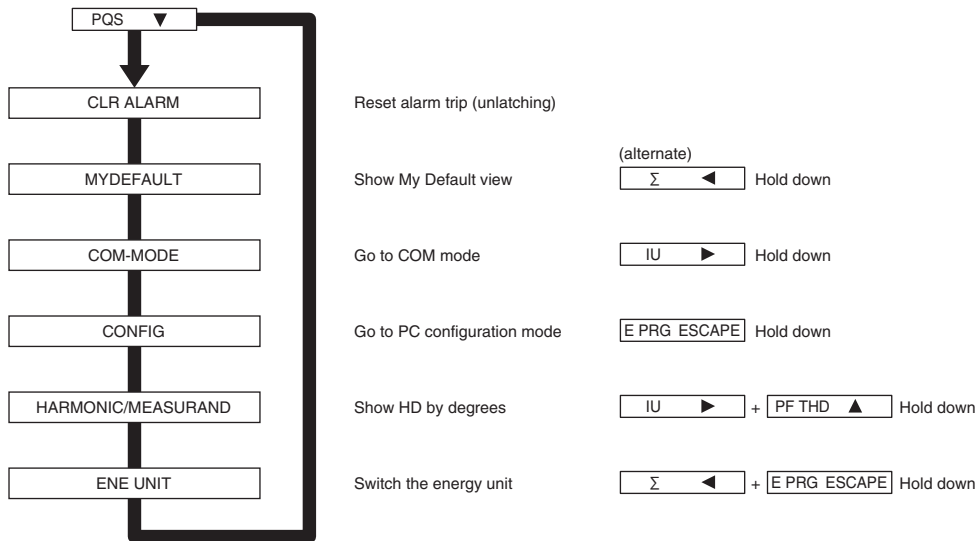

■ HOW TO SWITCH THE DISPLAY FOR LINE 4

Σ ◀ + [E PRG ESCAPE] Hold down both buttons for 1 second or more to switch the watt-hour unit with or without 'k.'

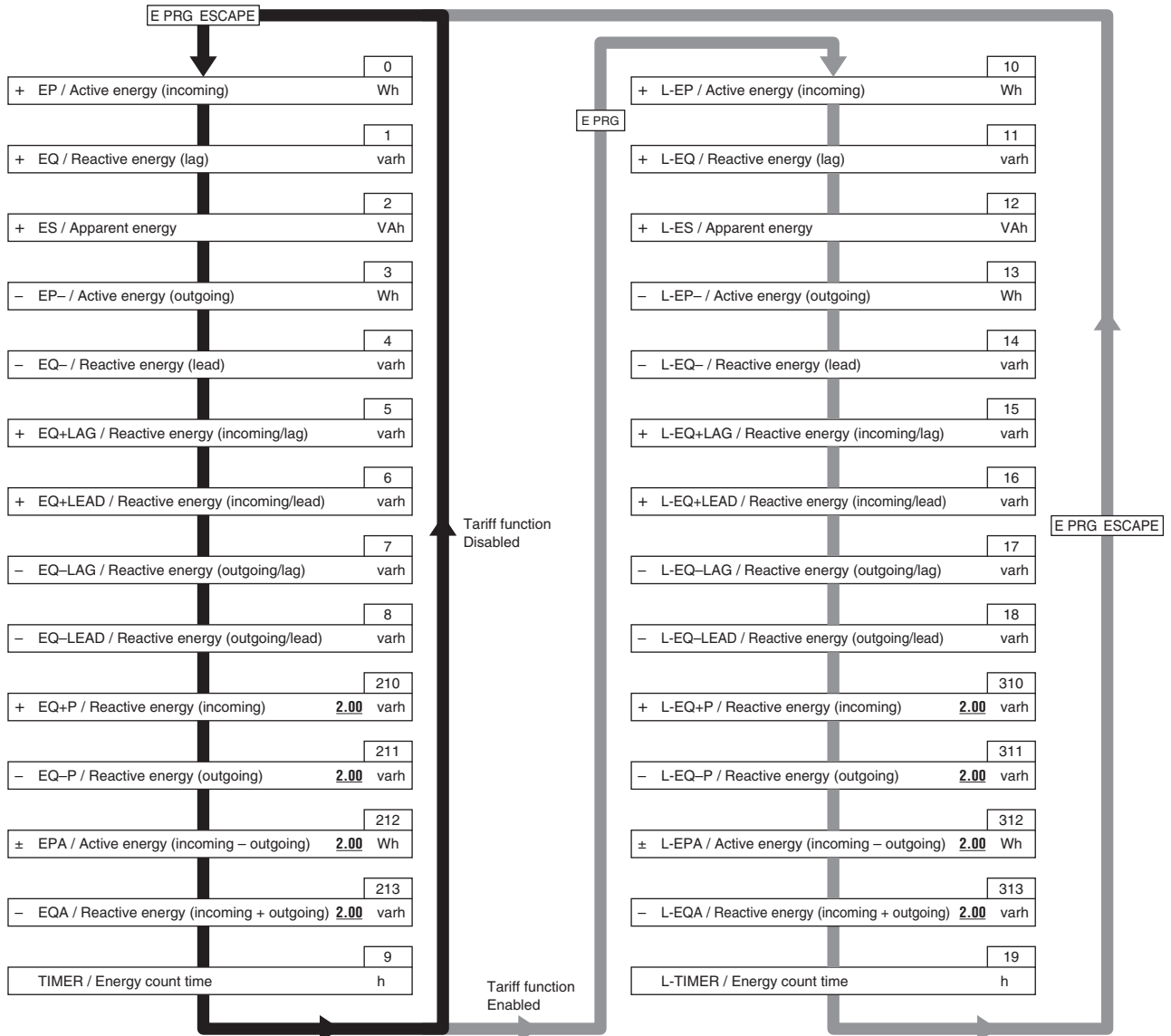

OL or ERR reading flashes in case of errors. Refer to "ERROR MESSAGES" section for detailed information.

PROGRAMMING FLOWCHART

PF THD ▲ PQS ▼ : Move between menu items

MAX ENTER : Select

E PRG ESCAPE : Go up one level in the chart

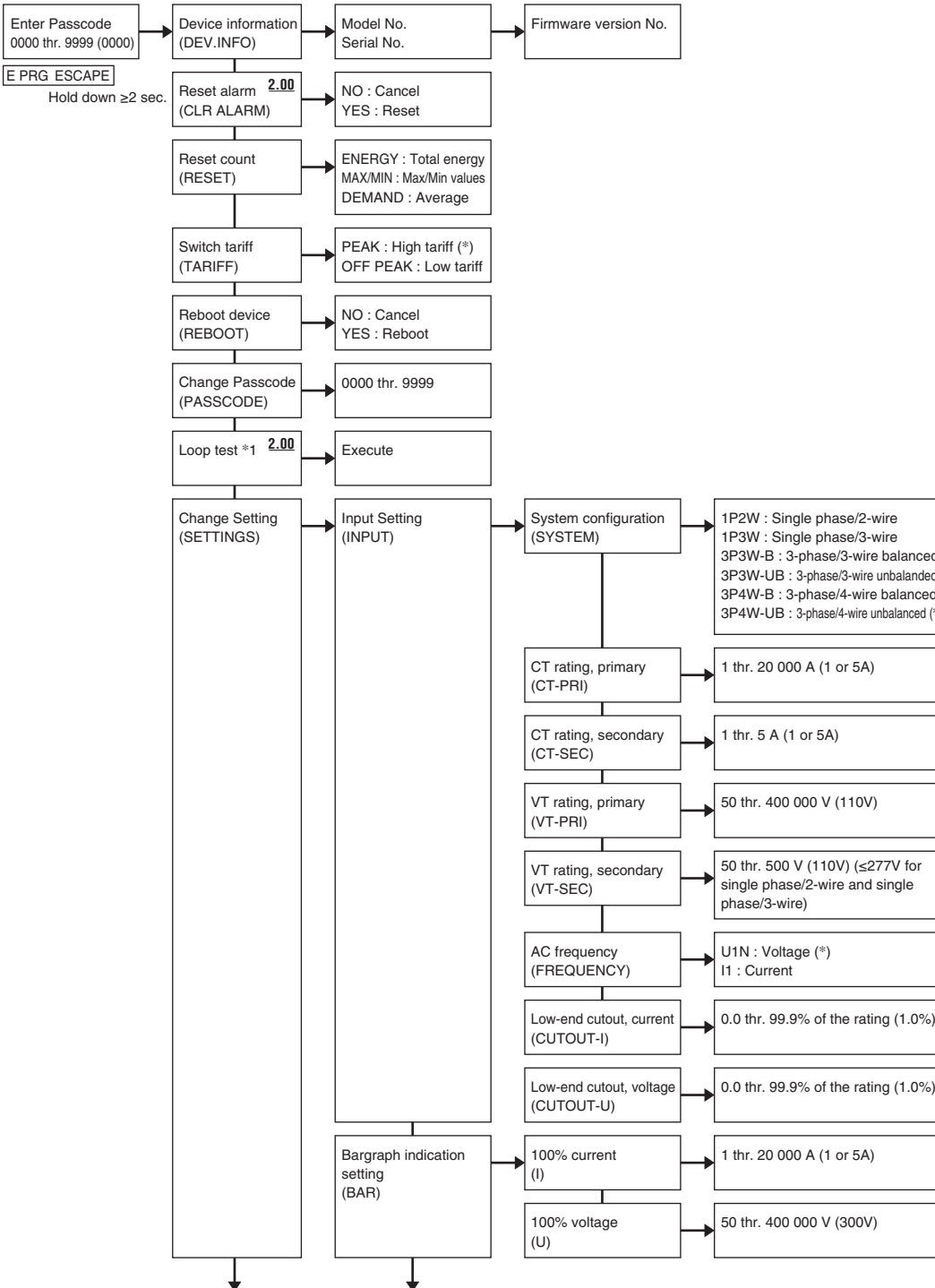

(*) or () : Factory setting

*1. Simulated output without applying actual input signals.

[Loop Test]

Press MAX ENTER button to switch among outputs. Press Σ ◀ IU ▶ PQS ▼ PF THD ▲ buttons to increase/decrease output signal or to change output status (ON or OFF).

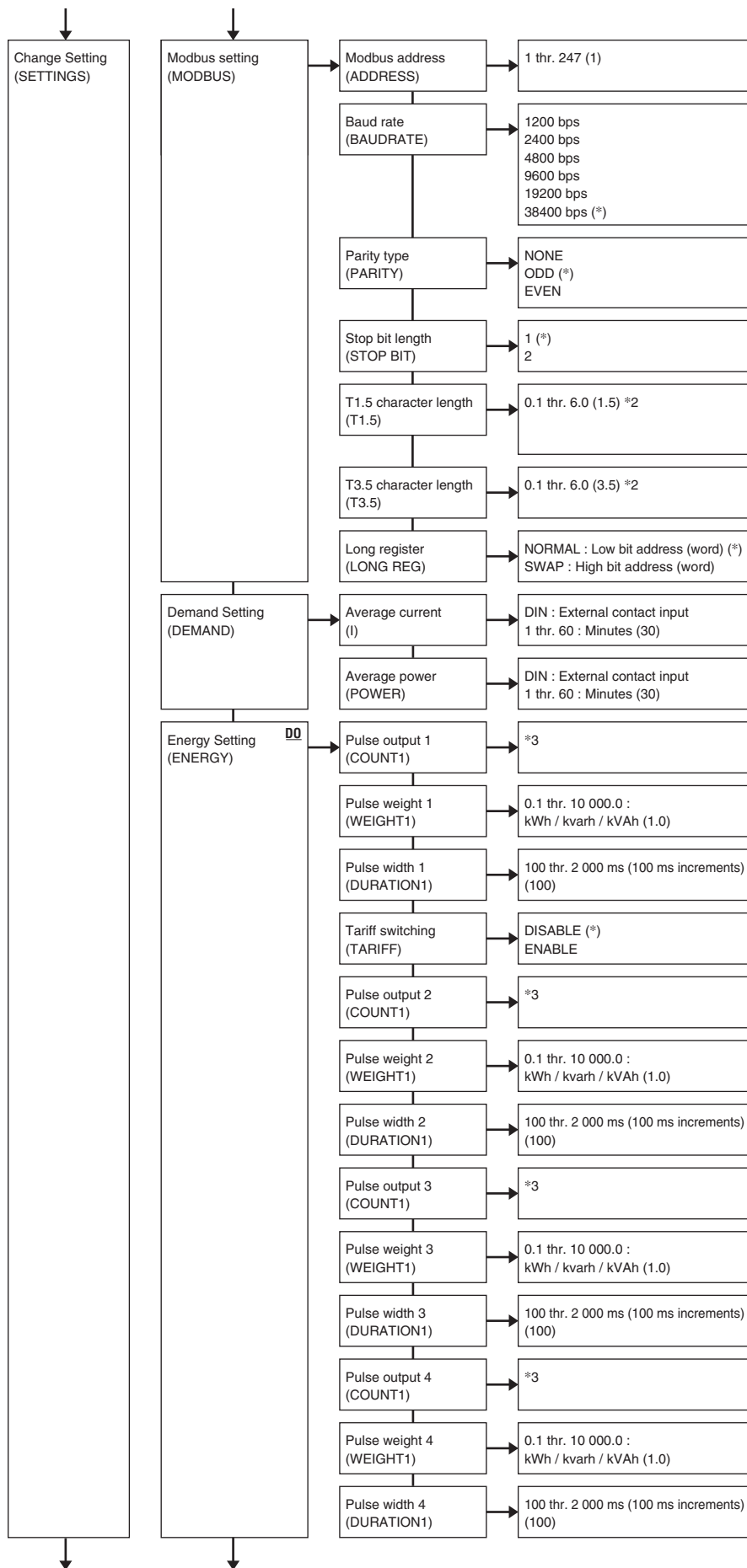

(*) or () : Factory setting

*2. $0.1 \leq T1.5 \text{ character length} < T3.5 \text{ character length} \leq 6.0$

*3. Refer to Modbus - Setting - Energy setting - Energy count type, for selectable options.

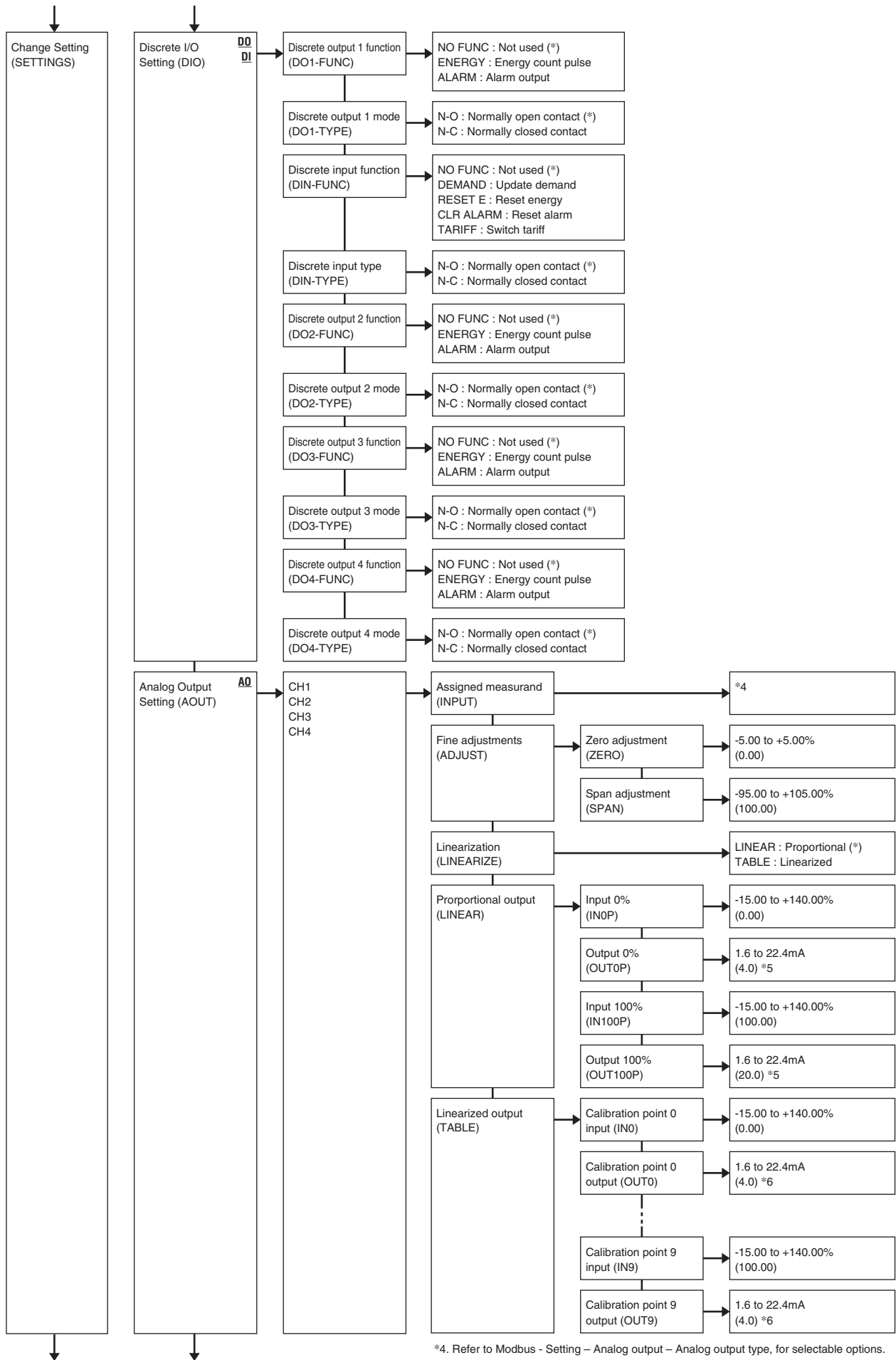

(*) or () : Factory setting

*4. Refer to Modbus - Setting - Analog output - Analog output type, for selectable options.
 *5. 0.4 to 5.6V for voltage output. Factory setting for 0%: 1V, 100%: 5V
 *6. 0.4 to 5.6V for voltage output. Factory setting: 1V

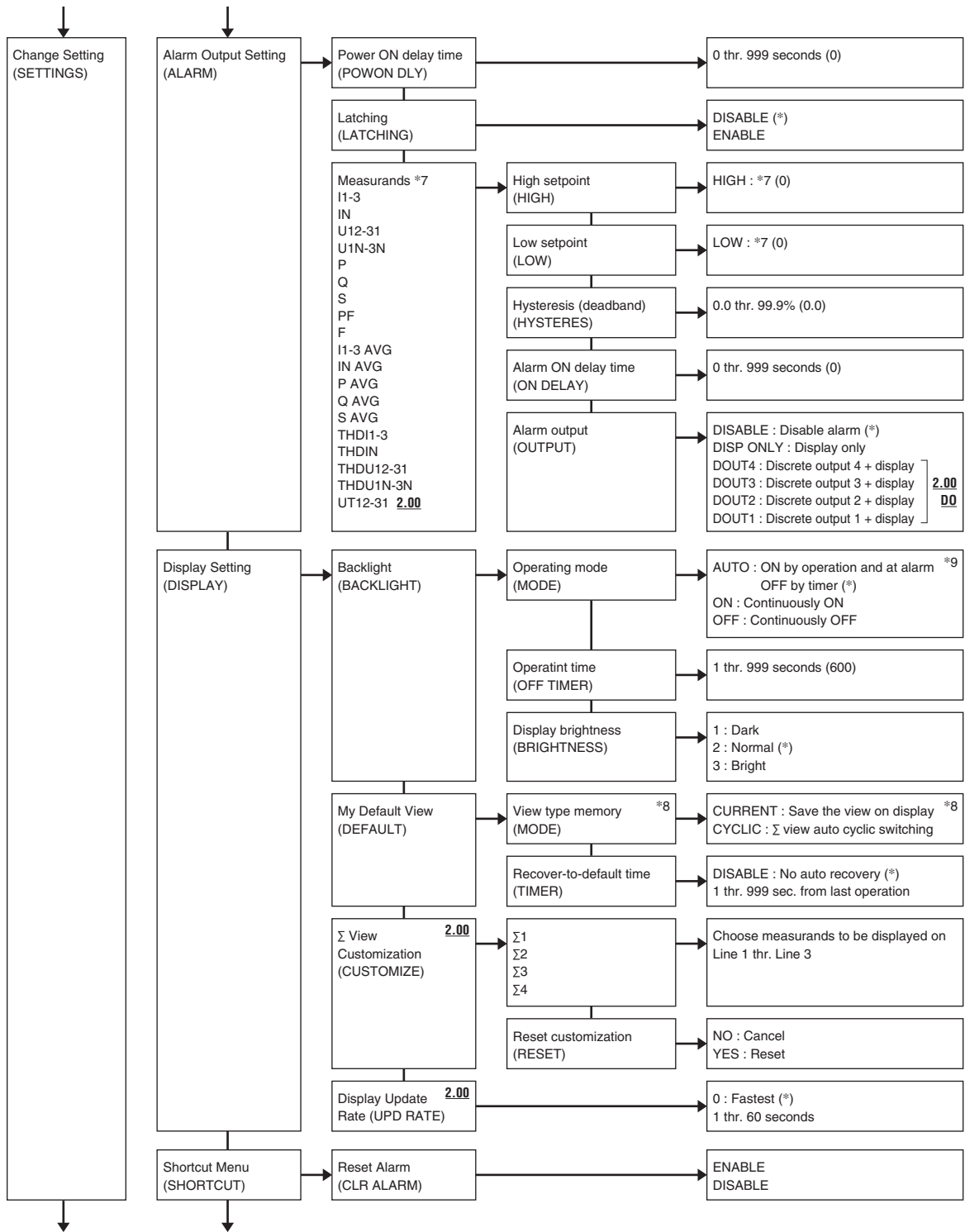

(*) or () : Factory setting

*7. Refer to Modbus - Setting – Alarm Setting. Factory setting for Frequency : HIGH = 6500, LO = 4500

*8. Ver.1.** View type memory (SAVE) → NO : Cancel
YES : Save the view on display

*9. The backlight turns on regardless of this setting in case of alarms/errors.

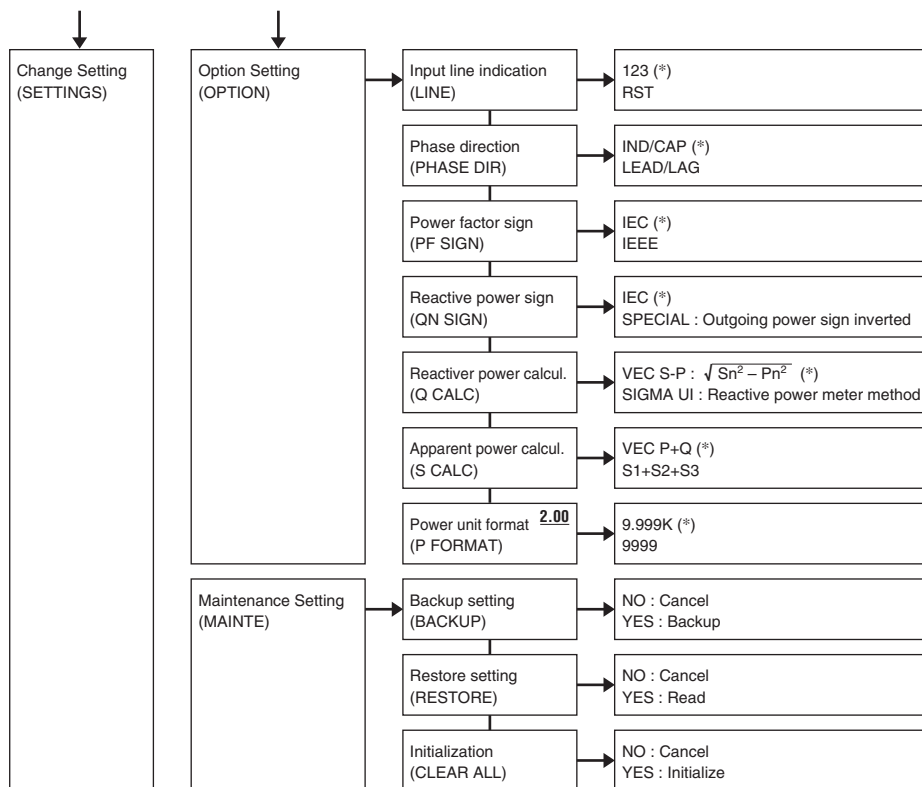

(*) or () : Factory setting

ALARM OUTPUT SETTING

ID *1	DEFINITION	LOW SETPOINT	HIGH SETPOINT	UNIT
I1-3	Current, Line 1 thr. Line 3	0.000	20 000.000	A
IN	Neutral current	0	20 000	A
U12-31	Delta voltage, Line 1 - 2, 2 - 3, 3 - 1	0.00	400 000.00	V
U1N-3N	Phase voltage, Phase 1 thr. Phase 3	0.00	400 000.00	V
P	Active power	-2 000 000 000	2 000 000 000	W
Q	Reactive power	-2 000 000 000	2 000 000 000	var
S	Apparent power	0	2 000 000 000	VA
PF	Power factor	-1.0000	1.0000	---
F	Frequency	45.00	65.00	Hz
I1-3 AVG	Average current, Line 1 thr. Line 3 (demand)	0.000	20 000.000	A
IN AVG	Average neutral current (demand)	0	20 000	A
P AVG	Average active power (demand)	-2 000 000 000	2 000 000 000	W
Q AVG	Average reactive power (demand)	-2 000 000 000	2 000 000 000	var
S AVG	Average apparent power (demand)	0	2 000 000 000	VA
THDI1-3	THD, Current, Line 1 thr. Line 3	0.0	999.9	%
THDIN	THD, Neutral current	0.0	999.9	%
THDU12-31	THD, Delta voltage, Line 1 - 2, 2 - 3, 3 - 1	0.0	999.9	%
THDU1N-3N	THD, Phase voltage, Phase 1 thr. Phase 3	0.0	999.9	%
UT12-31	Phase angle between voltages, Phase 1 - 2, 2 - 3, 3 - 1	-180	180	°

*1. Indicated while in alarm conditions.

PARAMETERS TO BE ASSIGNED TO ANALOG OUTPUTS

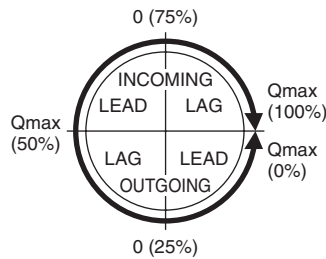
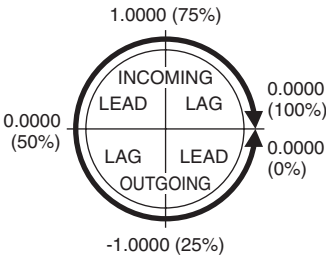
ID	DEFINITION	RANGE (0 to 100%)
NO ASSIGN	Not assigned *1	
I	Current	0 to CT primary rating
U	Voltage	0 to VT primary rating
P	Active power	\pm (VT primary rating \times CT primary rating \times n) *2
Q	Reactive power	\pm (VT primary rating \times CT primary rating \times n) *2
S	Apparent power	0 to (VT primary rating \times CT primary rating \times n) *2
PF	Power factor	-1.0000 to + 1.0000
F	Frequency	45.00 to 65.00
I1	Current, Line 1	0 to CT primary rating
I2	Current, Line 2	0 to CT primary rating
I3	Current, Line 3	0 to CT primary rating
IN	Neutral current	0 to CT primary rating
U12	Delta voltage, Line 1 – 2	0 to VT primary rating
U23	Delta voltage, Line 2 – 3	0 to VT primary rating
U31	Delta voltage, Line 3 – 1	0 to VT primary rating
U1N	Phase voltage, Phase 1	0 to VT primary rating
U2N	Phase voltage, Phase 2	0 to VT primary rating
U3N	Phase voltage, Phase 3	0 to VT primary rating
P1	Active power, Phase 1	\pm (VT primary rating \times CT primary rating \times n) *2
P2	Active power, Phase 2	\pm (VT primary rating \times CT primary rating \times n) *2
P3	Active power, Phase 3	\pm (VT primary rating \times CT primary rating \times n) *2
Q1	Reactive power, Phase 1	\pm (VT primary rating \times CT primary rating \times n) *2
Q2	Reactive power, Phase 2	\pm (VT primary rating \times CT primary rating \times n) *2
Q3	Reactive power, Phase 3	\pm (VT primary rating \times CT primary rating \times n) *2
S1	Apparent power, Phase 1	0 to (VT primary rating \times CT primary rating \times n) *2
S2	Apparent power, Phase 2	0 to (VT primary rating \times CT primary rating \times n) *2
S3	Apparent power, Phase 3	0 to (VT primary rating \times CT primary rating \times n) *2
PF1	Power factor, Phase 1	-1.0000 to + 1.0000
PF2	Power factor, Phase 2	-1.0000 to + 1.0000
PF3	Power factor, Phase 3	-1.0000 to + 1.0000
THDI1	THD, Current, Line 1	0.0 to 100.0
THDI2	THD, Current, Line 2	0.0 to 100.0
THDI3	THD, Current, Line 3	0.0 to 100.0
THDIN	THD, Neutral current	0.0 to 100.0
THDU12	THD, Delta voltage, Line 1 – 2	0.0 to 100.0
THDU23	THD, Delta voltage, Line 2 – 3	0.0 to 100.0
THDU31	THD, Delta voltage, Line 3 – 1	0.0 to 100.0
THDU1N	THD, Phase voltage, Phase 1	0.0 to 100.0
THDU2N	THD, Phase voltage, Phase 2	0.0 to 100.0
THDU3N	THD, Phase voltage, Phase 3	0.0 to 100.0
T-Q	Reactive power for bidirectional current	$Q_{max} = (CT \text{ primary rating}) \times (VT \text{ primary rating}) \times n$ *2 
T-PF	Power factor for bidirectional current	

*1. If it is set to "NO ASSIGN," the last value will be held until the power is turned off.

*2. Single-phase/2-wire: n = 1, Single-phase/3-wire: n = 2, Three-phase/3-wire: n = 3 / $\sqrt{3}$, Three-phase/4-wire: n = 3

SETTING EXAMPLES

■ SETTING INPUT CONFIGURATION

Input system: Three-phase / 3-wire, unbalanced load

CT ratio: 300A / 5A

VT ratio: 6600V / 110V

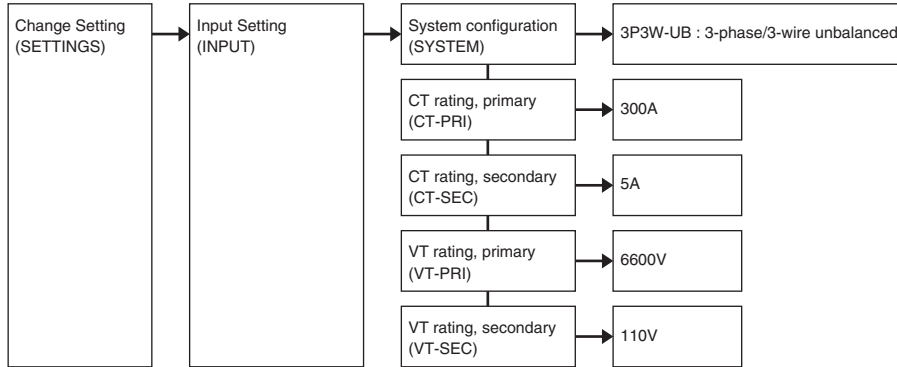

■ SETTING ANALOG OUTPUT

CH1: Voltage, 0 – 9000V input, 4 – 20mA output

CH2: Current, 0 – 150A input, 4 – 20mA output

CH3: Active power, 0 – 1715 kW, 4 – 20mA output

CH4: Power factor, LEAD 0.5 – 1 – LAG 0.5, 4 – 20mA output

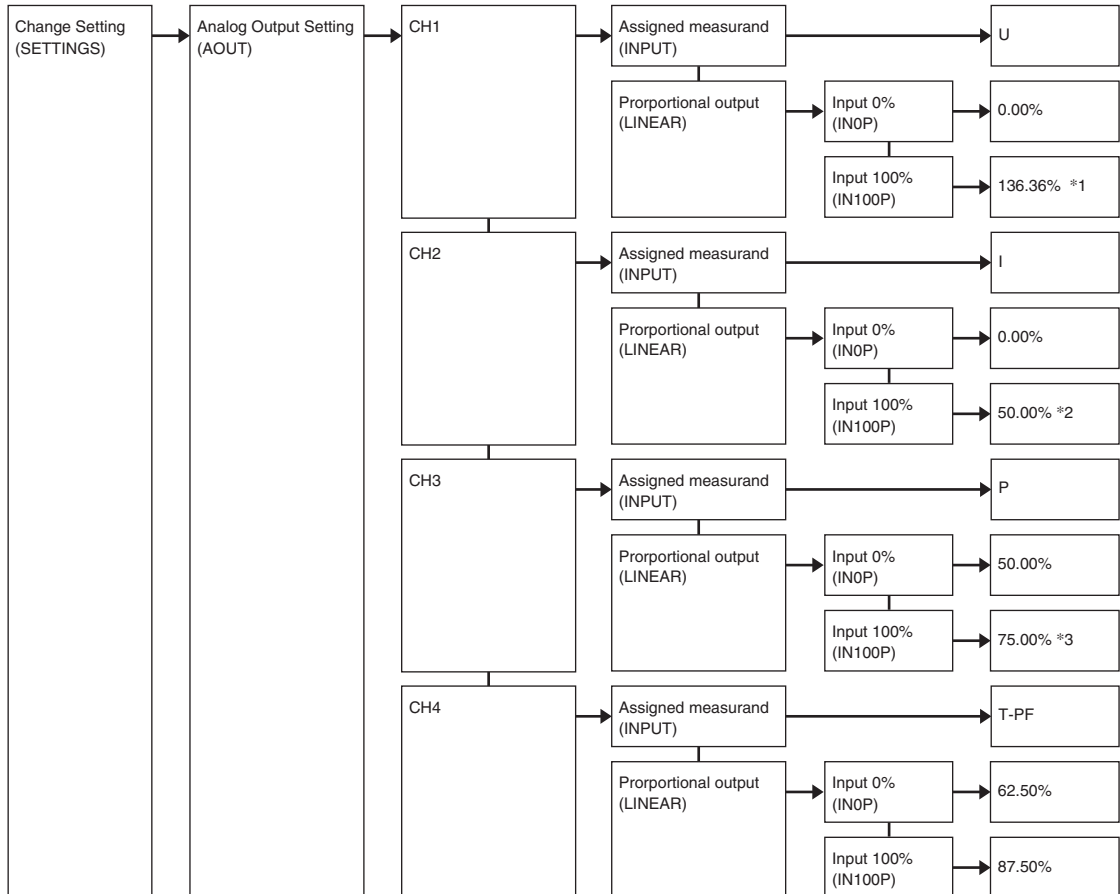

*1. 9000 = 1.36 x 6600 (primary VT rating)

*2. 150 = 0.5 x 300 (primary CT rating)

*3. 1715 kW = 75% of the full scale range -3429 to +3429 kW (6600 x 300 x 3 / $\sqrt{3}$)
 0 = 50% of the full scale range -3429 to +3429 kW.

■ **SETTING ALARM OUTPUT**

Measurand: Current
 Low setpoint: 50A
 High setpoint: 120A
 Hysteresis (deadband): 1%
 Alarm ON delay time: 1 second
 Discrete output: DO1

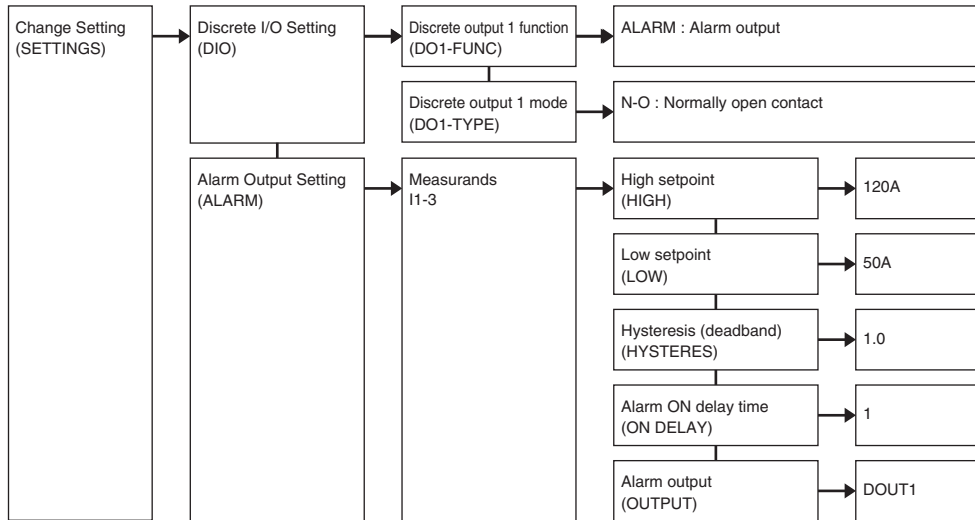

■ **SETTING ENERGY COUNT OUTPUT**

Measurand: Active energy
 Pulse weight: 1 kWh/count
 ON pulse width: 500 msec.
 Discrete output: DO2

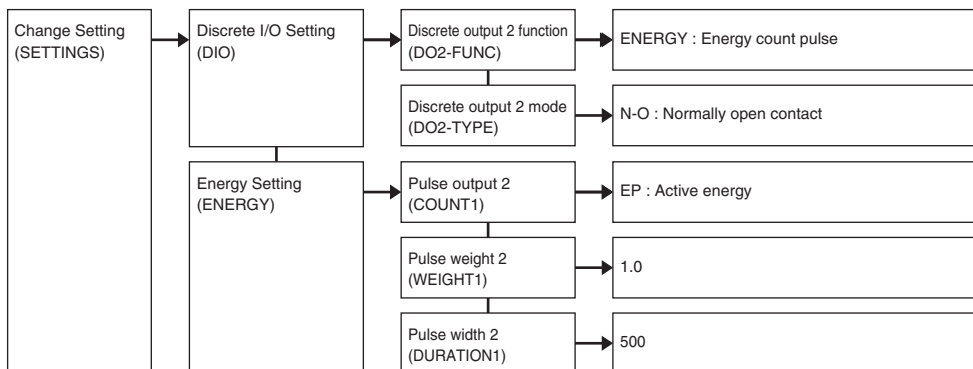

ERROR MESSAGES

ERR24

'ERR' followed by numerical figures means a system error. Each figure indicates a particular system error status if there are more than one digit of figures.

FIG	ERROR DIAGNOSTICS	WHAT TO DO
1	Firmware destroyed	Repair at the factory
2	Calibration data destroyed	Repair at the factory
3	System parameters destroyed System parameters stored in the device are destroyed, often due to excessive noise interference.	Initialize the system parameters and set them up again. Go to SETTINGS → MAINTENANCE → ALL CLEAR → YES
4	Energy reading data destroyed Energy reading data stored in the device are destroyed, often due to excessive noise interference.	Reset the energy readings (all energy and time count) to zero. Go to RESET → ENERGY
5	Average (demand) data destroyed Average (demand) data stored in the device are destroyed, often due to excessive noise interference.	Reset the average readings to zero. Go to RESET → DEMAND
6	Statistical data destroyed Statistical data (e.g. MAX/MIN values) stored in the device are destroyed, often due to excessive noise interference.	Reset the statistical data to zero. Go to RESET → MAX/MIN

OL FIU

'OL' followed by a space and alphabets means an input overload error. Each alphabet indicates a particular input error if there are more than one digit of alphabets.

CHR	ERROR DIAGNOSTICS	WHAT TO DO
F	Either U1 or I1 (selectable) input is lost or the input line frequency is out of measurable range (45 – 65 Hz).	Check the input signals/wiring.
I	Either of the current inputs is overload (120% or more of the rating).	Check the input signals.
U	Either of the voltage inputs is overload (120% or more of the rating).	Check the input signals.

MAINTENANCE

■ CLEANING

The front panel and operation keys should be gently wiped with a dry cloth.

Caution- Do not use alcohol, benzine, or any other solvents.

Fuji Electric France S.A.S.

46, Rue Georges Besse - Z I du Brézet - 63 039 Clermont-Ferrand cedex 2 FRANCE

France : Tél. 04 73 98 26 98 - Fax 04 73 98 26 99

International : Tel. (33) 4 7398 2698 - Fax. (33) 4 7398 2699

E-mail sales.dpt@fujielectric.fr – Web : www.fujielectric.fr



Specifications are subject to change without notice.