



Compact Inverter

FRENIC-Mini

Single-phase 100 V series: FRN0001 to 0005C2S-6U

CAUTION

Thank you for purchasing our FRENIC-Mini series of inverters.

- This manual is a supplement to the FRENIC-Mini Instruction Manual (INR-SI47-1729-E, INR-SI47-1745-E). It describes the FRENIC-Mini output ratings (Inverter types FRN_ _ _ _C2S-6U) and basic connection. For other descriptions, refer to the original manual.
- Improper handling might result in incorrect operation, a short life, or even a failure of this product as well as the motor.
- Deliver this manual to the end user of this product. Keep this manual in a safe place until this product is discarded.

Chapter 2 MOUNTING AND WIRING OF THE INVERTER

2.3.2 Terminal arrangement and screw specifications

(1) Arrangement of the main circuit terminals

Table 2.3 Main Circuit Terminals

Power supply voltage	Nominal applied motor (HP)	Inverter type	Terminal screw size	Tightening torque (lb-in)	Refer to:
Single-phase 100 V	1/8	FRN0001C2S-6U	M3.5	10.6	Figure C
	1/4	FRN0002C2S-6U			
	1/2	FRN0003C2S-6U			
	1	FRN0005C2S-6U			

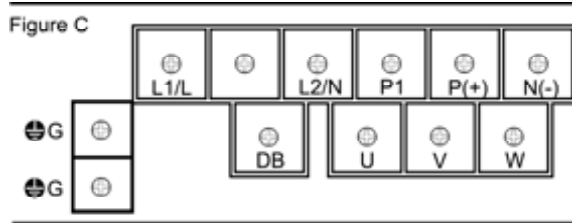

2-3

2.3.3 Recommended wire sizes

Table 2.6 lists the recommended wire sizes. The recommended wire sizes for the main circuit terminals at an ambient temperature of 50°C are indicated for two types of wire: HIV single wire (for the maximum allowable temperature 75°C) (before a slash (/)) and IV single wire (for 60°C) (after a slash (/)).

Table 2.6 Recommended Wire Sizes

Power supply voltage	Nominal applied motor (HP)	Inverter type	*1 Recommended wire size (AWG)						
			Main circuit					Control circuit	
			Main circuit power input [L1/R, L2/S, L3/T] [L1/L, L2/N] Grounding [G]		Inverter output [U, V, W]	DCR [P1, P (+)]	Braking resistor [P (+), DB]		
			w/ DCR	w/o DCR *2					
Single-phase 100 V	1/8	FRN0001C2S-6U	14/14	14/14	14/14	*3	14/14	20	
	1/4	FRN0002C2S-6U							14/14
	1/2	FRN0003C2S-6U							
	1	FRN0005C2S-6U							14/12

DCR: DC reactor

*1 Use crimp terminals covered with an insulated sheath or insulating tube.

*2 Wire sizes are calculated on the basis of input RMS current under the condition that the power supply capacity and impedance are 50 kVA and 5%, respectively.

*3 Insert the DC reactor (DCR) in either of the primary power input lines. Refer to Chapter 10 for more details.

2-5

2.3.5 Wiring for main circuit terminals and grounding terminals

② Inverter output terminals, U, V, W and grounding terminal (⏏G)

- 1) Connect the three wires of the three-phase motor to terminals U, V, and W, aligning phases each other.
- 2) Connect the grounding wire of terminals U, V, and W to the grounding terminal (⏏G).
- 3) If the cable from the inverter to the motor is very long, a high-frequency current may be generated by stray capacitance between the cables and result in an overcurrent trip of the inverter, an increase in leakage current, or a reduction in current indication precision.

When a motor is driven by a PWM-type inverter, the motor terminals may be subject to surge voltage generated by inverter element switching. If the motor cable (with 460 V series motors, in particular) is particularly long, surge voltage will deteriorate motor insulation. To prevent this, use the following guidelines:

Inverters of 7.5 HP or above			
Motor Insulation Level	1000 V	1300 V	1600 V
460 VAC Input Voltage	66 ft (20 m)	328 ft (100 m)	1312 ft (400 m)*
230 VAC Input Voltage	1312 ft (400 m)*	1312 ft (400 m)*	1312 ft (400 m)*

Inverters of 5 HP or below			
Motor Insulation Level	1000 V	1300 V	1600 V
460 VAC Input Voltage	66 ft (20 m)	165 ft (50 m)	165 ft (50 m)*
230 VAC Input Voltage	328 ft (400 m)*	328 ft (100 m)*	328 ft (100 m)*

* For this case the cable length is determined by secondary effects and not voltage spiking.

 **Note** When a motor protective thermal O/L relay is inserted between the inverter and the motor, the thermal O/L relay may malfunction (particularly in the 460 V series), even when the cable length is 165 ft (50 m) or less. To correct, insert a filter or reduce the carrier frequency. (Use function code F26 (Motor sound).)

③ DC reactor terminals, P1 and P (+)

WARNING

When wiring the inverter to the power supply of 50 kVA or more, be sure to connect an optional DC reactor (DCR).

Otherwise, fire could occur.

Chapter 5 FUNCTION CODES

This chapter sets forth function codes whose setting ranges differ according to the input voltage for the single-phase 100 V class series (FRN-____C2S-6U).

5.1 Function Code Tables

Code	Name	Data setting range	Increment	Unit	Change when running	Data copying	Default setting	Refer to page:
F05	Rated Voltage at Base Frequency 1	0: Output a voltage in proportion to input voltage 80 to 240: Output an AVR-controlled voltage (Note 1) 160 to 500: Output an AVR-controlled voltage (Note 2)	1	V	N	Y2	0	5-23
F06	Maximum Output Voltage 1	80 to 240: Output an AVR-controlled voltage (Note 1) 160 to 500: Output an AVR-controlled voltage (Note 2)	1	V	N	Y2	200	
F21	DC Braking 1 (Braking level)	0 to 100 (Note 3)	1	%	Y	Y	0	5-37
F44	Current Limiter (Level)	20 to 180 (Note 3)	1	%	Y	Y	160	5-42
P63	Permanent magnet synchronous motor *1 (Induced voltage)	0 (Disable PMSM), 80 to 240 (Note 1) 160 to 500 (Note 2)	1	V	N	Y2	0	–
H15	Restart Mode after Momentary Power Failure (Continuous running level) *1	200 to 300 (Note 1) 400 to 600 (Note 2)	1	V	Y	Y2	235 470	–
H27	Thermistor for Motor (Level) *2	0.00 to 5.00	0.01	V	Y	Y	1.6	–
H51	Non-linear V/f Pattern 1 (Voltage)	0 to 240: Output an AVR-controlled voltage (Note 1) 0 to 500: Output an AVR-controlled voltage (Note 2)	1	V	N	Y2	0	5-23
H53	Non-linear V/f Pattern 2 (Voltage)	0 to 240: Output an AVR-controlled voltage (Note 1) 0 to 500: Output an AVR-controlled voltage (Note 2)	1	V	N	Y2	0	
A03	Rated Voltage at Base Frequency 2	0: Output a voltage in proportion to input voltage 80 to 240V: Output an AVR-controlled voltage (Note 1) 160 to 500V: Output an AVR-controlled voltage (Note 2)	1	V	N	Y2	0	–
A04	Maximum Output Voltage 2	80 to 240V: Output an AVR-controlled voltage (Note 1) 160 to 500V: Output an AVR-controlled voltage (Note 2)	1	V	N	Y2	200	–
A10	DC Braking 2 (Braking level)	0 to 100 (Note 3)	1	%	Y	Y	0	–
J68	Braking Signal (Brake OFF current)	0 to 200 (Note 3)	1	%	Y	Y	100	–

*1 The PMSM drive is available in the ROM version 0500 or later.

*2 In the ROM version 0800 or later, the factory default is changed from 0.16 to 1.6.

(Note 1) For the three-phase 200 V, single-phase 200 V, and single-phase 100 V class series

(Note 2) For the three-phase 400 V class series

(Note 3) The reference current for the single-phase 100 class series is as listed below.

Nominal applied motor (HP)	1/8	1/4	1/2	1
Reference current (A)	0.8	1.5	3.0	5.0

Table A Fuji Standard Motor Parameters

Power supply voltage	Nominal applied motor (HP)	Inverter type	Fuji's standard torque boost (%)	Nominal rated current of Fuji standard motor (A)	Nominal rated capacity of Fuji standard motor (kW)
			Function code F09/A05	Function code F11/A07/E34/E37	Function code P02/A16
Single-phase 100 V	1/8	FRN0001C2S-6U	8.4	0.68	0.10
	1/4	FRN0002C2S-6U	8.4	1.40	0.20
	1/2	FRN0003C2S-6U	7.1	2.00	0.40
	1	FRN0005C2S-6U	6.8	3.00	0.75

5-20

5.2 Details of Function Codes

F20 to F22	DC Braking 1 (Braking starting frequency, Braking level, and Braking time)
H95	DC Braking (Braking response mode)

■ Braking level (F21) for single-phase 100 V class series

The braking level setting should be calculated from the DC braking level I_{DB} (A) based on the reference current I_{ref} (A), as shown below.

$$\text{Setting (\%)} = \frac{I_{DB} \text{ (A)}}{I_{ref} \text{ (A)}} \times 100$$

(Example) Setting the braking level I_{DB} at 4.2 Amp (A) for 1 HP standard motors

$$\text{Setting (\%)} = \frac{4.2 \text{ (A)}}{5.0 \text{ (A)}} \times 100 = 84$$

Nominal applied motor (HP)	1/8	1/4	1/2	1
Reference current I_{ref} (A)	0.8	1.5	3.0	5.0

■ **Voltage adjustment (F30) for single-phase 100 V class series**

Outputting the output current in an analog format (FMA) (F31 = 2)

The analog output terminal [FMA] outputs 10 V, that is, 200% of the reference current I_{ref} (A), supposing the output gain selected with F30 as 100%. Therefore, to adjust the output voltage, you need to set the output gain at terminal [FMA] (F30) based on the conversion result obtained by the following expression:

- Conversion formula for calculating the output gain which is required for outputting the voltage V (V) via terminal [FMA] when current I (A) flows across the inverter

$$\text{Output gain} = 2 \times \frac{I_{ref} \text{ (A)}}{I \text{ (A)}} \times \frac{V \text{ (V)}}{10 \text{ (V)}} \times 100$$

I_{ref} (A): Reference current (A)

 The reference current is given in the table for F20 to F22 on page 5-37.

According to the conversion result, the output voltage to terminal [FMA] can be calculated as shown below.

$$\text{Analog output voltage (V)} = \frac{I \text{ (A)}}{2 \times I_{ref} \text{ (A)}} \times \frac{\text{Output gain (F30)}}{100} \times 10 \text{ (V)}$$

(Example) Outputting analog voltage 8V for 1 HP standard motors when the inverter output current is 4.2A

$$\text{Output gain} = 2 \times \frac{5.0 \text{ (A)}}{4.2 \text{ (A)}} \times \frac{8 \text{ (V)}}{10 \text{ (V)}} \times 100 = 190.4$$

$$\text{Analog output voltage (V)} = \frac{4.2 \text{ (A)}}{2 \times 5.0 \text{ (A)}} \times \frac{190}{100} \times 10 \text{ (V)} = 7.98$$

Reference table

To output analog 10 V at 200% of the rated current of any of the single-phase 100 V class series of inverters, set the output gain at terminal [FMA] (F30) as listed below.

Nominal applied motor (HP)	1/8	1/4	1/2	1
Output gain to be set to F30 (%)	114	107	120	119

■ **Function (F31)**

F31 specifies what is output to analog output terminal [FMA].

Data for F31	[FM] output	Function (Monitor the following)	Meter scale (Full scale at 100%)
3	Output voltage	Output voltage (RMS) of the inverter	250 V for three-phase 200 V, single-phase 200 V, and single-phase 100 V class series 500 V for three-phase 400 V class series
9	DC link bus voltage	DC link bus voltage of the inverter	500 V for three-phase 200 V, single-phase 200 V, and single-phase 100 V class series 1000 V for three-phase 400 V class series

F43, F44 Current Limiter (Mode selection, Level)

■ Level (F44) for single-phase 100 V class series

The limiting level setting should be calculated from the current limiting level I_{limit} (A) based on the reference current I_{ref} (A), as shown below.

$$\text{Setting (\%)} = \frac{I_{limit} \text{ (A)}}{I_{ref} \text{ (A)}} \times 100$$

(Example) Setting the current limiting level I_{limit} at 4.2 A for 1 HP standard motors

$$\text{Setting (\%)} = \frac{4.2 \text{ (A)}}{5.0 \text{ (A)}} \times 100 = 84$$

 The reference current is given in the table for F20 to F22 on page 5-37.

F50, F51 Electronic Thermal Overload Protection for Braking Resistor
(Discharging capability and Allowable average loss)

■ External Braking Resistors
Standard models

Power supply voltage	Inverter type	Braking resistor		Resistance (Ω)	Continuous braking (100% braking torque)		Intermittent braking (Period: 100 s or less)	
		Type	Qty.		Discharging capacity (kW)	Braking time (s)	Allowable average loss (kW)	Duty (%ED)
Single-phase 100 V	FRN0003C2S-6U	DB0.75-2	1	100	9	45	0.044	22
	FRN0005C2S-6U				17		0.068	18

10% ED models

Power supply voltage	Inverter type	Braking resistor		Resistance (Ω)	Continuous braking (100% braking torque)		Intermittent braking (Period: 100 s or less)	
		Type	Qty.		Discharging capacity (kW)	Braking time (s)	Allowable average loss (kW)	Duty (%ED)
Single-phase 100 V	FRN0003C2S-6U	DB0.75-2C	1	100	50	250	0.075	37
	FRN0005C2S-6U					133		20

Chapter 8 SPECIFICATIONS

8.1 Standard Models

8.1.4 Single-phase 100 V class series

Item		Specifications				
Type (FRN_ _ _ _C2S-6U)		0001	0002	0003	0005	
Nominal applied motor (HP) *1		1/8	1/4	1/2	1	
Output Ratings	Rated capacity (kVA) *2	0.26	0.53	0.95	1.6	
	Rated voltage (V) *3	Three-phase, 200 to 240 V (with AVR function)				
	Rated current (A)	0.7	1.4	2.5	4.2	
	Overload capability	150% of rated output current for 1 min or 200% of rated output current for 0.5 s				
	Rated frequency (Hz)	50,60 Hz				
Input Ratings	Phases, voltage, frequency	Single-phase, 100 to 120 V, 50/60 Hz				
	Voltage and frequency variations	Voltage: +10 to -10%, Frequency: +5 to -5%				
	Rated current (A) *6	(w/ DCR)	2.2	3.8	6.4	12.0
		(w/o DCR)	3.6	5.9	9.5	16.0
Required power supply capacity (kVA) *7	0.3	0.5	0.7	1.3		
Braking	Torque (%) *8	150		100		
	DC braking	Braking starting frequency*9: 0.0 to 60.0 Hz, Braking time: 0.0 to 30.0 s, Braking level: 0 to 100%				
	Braking transistor	--		Built-in		
Applicable safety standards		UL508C (under application)				
Enclosure		IP20 (IEC 60529:1989), UL open type (UL50)				
Cooling method		Natural cooling				
Mass (lbs.)		1.5	1.5	1.8	2.9	

*1 Fuji 4-pole standard motors

*2 Refers to the rated capacity assuming the rated output voltage as 220 V.

*3 The inverter cannot output voltage that is 2 or more times its rated voltage.

*6 Refers to the estimated value to apply when the power supply capacity is 50 kVA and the inverter is connected to the %X = 5% power supply.

*7 Refers to the value to apply when a DC reactor (DCR) is used.

*8 Refers to the average braking torque to apply when the motor running alone decelerates from 60 Hz with the AVR control being OFF. (It varies with the efficiency of the motor.)

*9 Available only for induction motor drive.

(Note) When driven by 100 VAC, the single-phase 100 V class series of inverters limit their shaft output and maximum output torque as listed below. This is to prevent their output voltage from decreasing when load is applied.

	Shaft output (%)	Maximum torque (%)
w/o DC reactor (DCR)	90	150
w/ DC reactor (DCR)	85	120

8.3 Terminal Specifications

8.3.2 Connection diagram in operation by external signal inputs

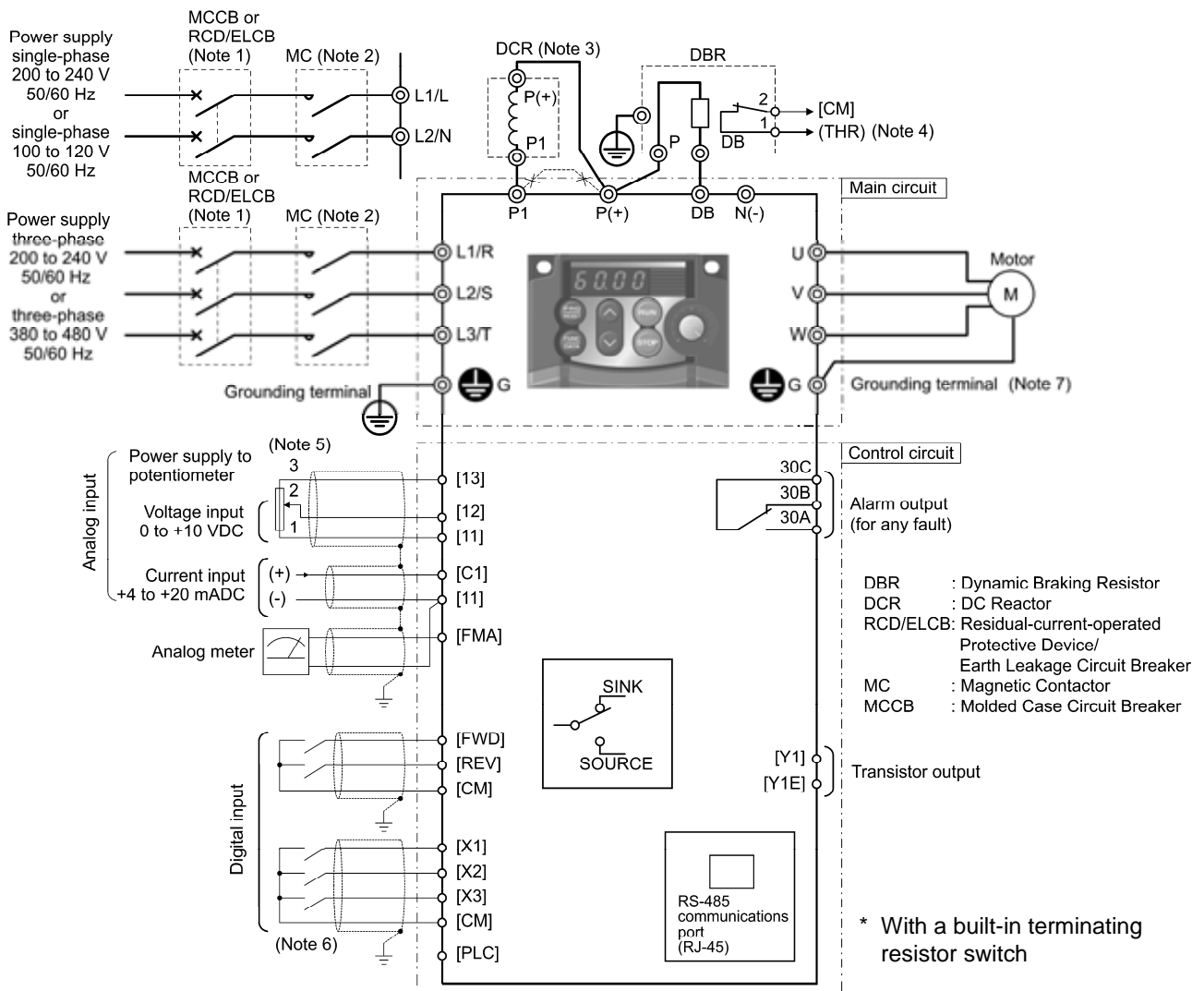

- (Note 1) Install a recommended molded case circuit breaker (MCCB) or a residual-current-operated protective device (RCD)/earth leakage circuit breaker (ELCB) (with overcurrent protection) in the primary circuit of the inverter to protect wiring. Do not use an MCCB or RCD/ELCB whose capacity exceeds the recommended rated current.
- (Note 2) A magnetic contactor (MC) should, if necessary, be mounted independent of the MCCB or ELCB to cut off the power fed to the inverter. Refer to page 9-1 for details. MCs or solenoids that will be installed close to the inverter require surge absorbers to be connected in parallel to their coils.
- (Note 3) When connecting a DC reactor (option), remove the jumper bar from terminals [P1] and [P+].
Note that the terminal assignment of single-phase 100 V class series of inverters differs that of the above diagram. For details about the terminal assignment, see Figure 10.1 "Connection Diagram of DC reactor (DCR)" in Chapter 10.
- (Note 4) The **THR** function can be used by assigning "9" (External alarm) to any of terminals [X1] to [X3], [FWD] or [REV] (function code E01 to E03, E98, or E99). For details, refer to Chapter 5.
- (Note 5) Frequency can be set by connecting a frequency setting device (external potentiometer) between terminals [11], [12], and [13] instead of inputting voltage signal (0 to +10 VDC or 0 to +5 VDC) between terminals [12] and [11].
- (Note 6) For the wiring of the control circuit, use shielded or twisted wires. When using shielded wires, connect the shields to earth. To prevent malfunction due to noise, keep the control circuit wiring away from the main circuit wiring as far as possible (recommended: 10 cm or longer), and never set them in the same wire duct. When crossing the control circuit wiring with the main circuit wiring, set them at right angles.
- (Note 7) It is recommended for noise control that 3-phase, 4-wire cable be used for the motor wiring. Connect grounding wires of the motor to the grounding terminal \ominus G on the inverter.

8.4 External Dimensions

8.4.1 Standard models

Unit: inch [mm]

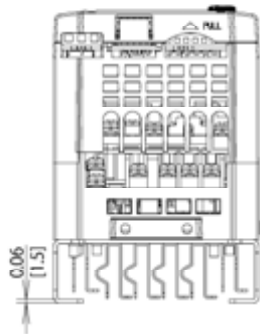
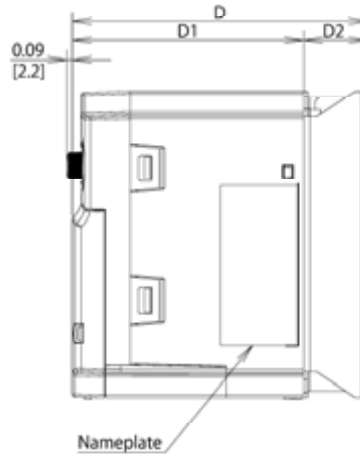
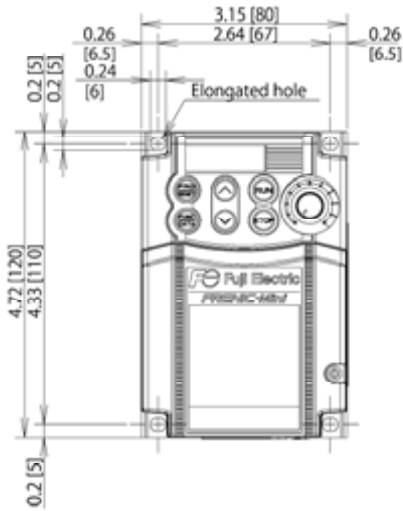

Power supply voltage	Inverter type	Dimensions inch [mm]		
		D	D1	D2
Single-phase 100 V	FRN0001C2S-6U	3.94 [100]	3.54 [90]	0.39 [10]
	FRN0002C2S-6U			
	FRN0003C2S-6U	4.53 [115]	0.98 [25]	

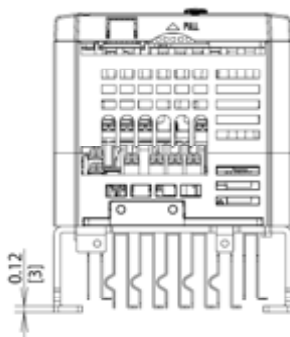
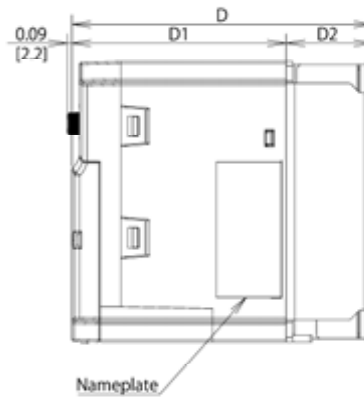
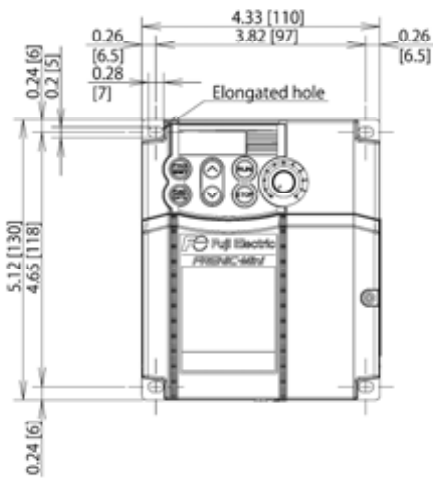

Power supply voltage	Inverter type	Dimensions inch [mm]		
		D	D1	D2
Single-phase 100 V	FRN0005C2S-6U	5.47 [139]	3.90 [99]	1.57 [40]

8.5 Protective Functions

Name	Description	LED monitor displays	Alarm output [30A,B,C]
Overvoltage protection	<p>The inverter stops the inverter output upon detecting an overvoltage condition (400 VDC for three-phase 200 V, single-phase 200 V, and single -phase 100 V class series; 800 VDC for three -phase 400 V class series) in the DC link bus.</p> <p>This protection is not assured if excess AC line voltage is applied inadvertently.</p>	During acceleration	Yes
		During deceleration	
		During running at constant speed (Stopped)	
Undervoltage protection	<p>Stops the inverter output when the DC link bus voltage drops below the undervoltage level (200 VDC for three-phase 200 V, single-phase 200 V, and single-phase 100 V class series; 400 VDC for three-phase 400 V class series).</p> <p>However, if data "4 or 5" is selected for F14, no alarm is output even if the DC link bus voltage drops.</p>	LL	Yes (Note)

(Note) No alarm output depending upon the data setting of the function code.

Chapter 9 LIST OF PERIPHERAL EQUIPMENT AND OPTIONS

	Name of peripheral equipment	Function and application																							
Main peripheral equipment	Molded case circuit breaker (MCCB) Residual-current-operated protective device (RCD) /Earth leakage circuit breaker (ELCB)* * with overcurrent protection	<p>MCCBs are designed to protect the power circuits between the power control board and inverter's main terminals (L1/R, L2/S and L3/T for three-phase power, L1/L and L2/N for single-phase power) from overload or short-circuit which in turn prevents secondary disasters caused by the inverter malfunctioning.</p> <p>RCDs/ELCBs function in the same way as MCCBs. Use the MCCBs and RCDs/ELCBs that satisfy the recommended rated current listed below.</p> <table border="1" data-bbox="412 607 1366 909"> <thead> <tr> <th rowspan="2">Power supply voltage</th> <th rowspan="2">Nominal applied motor (HP)</th> <th rowspan="2">Inverter type</th> <th colspan="2">Recommended rated current (A) of MCCB and RCD/ELCB</th> </tr> <tr> <th>w/ DC reactor</th> <th>w/o DC reactor</th> </tr> </thead> <tbody> <tr> <td rowspan="4">Single-phase 100 V</td> <td>1/8</td> <td>FRN0001C2S-6U</td> <td rowspan="2">5</td> <td>5</td> </tr> <tr> <td>1/4</td> <td>FRN0002C2S-6U</td> <td>10</td> </tr> <tr> <td>1/2</td> <td>FRN0003C2S-6U</td> <td>10</td> <td>15</td> </tr> <tr> <td>1</td> <td>FRN0005C2S-6U</td> <td>15</td> <td>20</td> </tr> </tbody> </table> <div data-bbox="412 936 1366 1227" style="border: 1px solid black; padding: 5px;"> <p style="text-align: center;"> WARNING</p> <p>When connecting the inverter to the power supply, add a recommended molded case circuit breaker (MCCB) or a residual-current-operated protective device (RCD)/earth leakage circuit breaker (ELCB)* in the path of power supply. Do not use the devices with the rated current out of the recommended range. *With overcurrent protection</p> <p>Fire could occur.</p> </div> <p>Select the MCCB or RCD/ELCB with appropriate rated current and breaking capacity according to the power supply capacity.</p>	Power supply voltage	Nominal applied motor (HP)	Inverter type	Recommended rated current (A) of MCCB and RCD/ELCB		w/ DC reactor	w/o DC reactor	Single-phase 100 V	1/8	FRN0001C2S-6U	5	5	1/4	FRN0002C2S-6U	10	1/2	FRN0003C2S-6U	10	15	1	FRN0005C2S-6U	15	20
	Power supply voltage	Nominal applied motor (HP)				Inverter type	Recommended rated current (A) of MCCB and RCD/ELCB																		
			w/ DC reactor	w/o DC reactor																					
	Single-phase 100 V	1/8	FRN0001C2S-6U	5	5																				
		1/4	FRN0002C2S-6U		10																				
1/2		FRN0003C2S-6U	10	15																					
1		FRN0005C2S-6U	15	20																					

Chapter 10 APPLICATION OF DC REACTORS (DCRs)

Since the "Japanese Guideline for Suppressing Harmonics in Home and General-purpose Appliances" issued by the Ministry of International Trade and Industry (Currently the Ministry of Economy, Trade and Industry) was revised in January 2004, the general-purpose inverters have no longer been subject to the guideline. Individual inverter manufacturers have voluntarily employed harmonics suppression measures. It is recommended that DC reactors (DCRs) specified in Table 10.1 be connected to the FRENIC-Mini series of inverters.

Table 10.1 List of DC Reactors (DCRs)

Power supply voltage	Nominal applied motor (HP)	Applicable inverter type	DCR type
Single-phase 100 V	1/8	FRN0001C2S-6U	DCR2-0.75
	1/4	FRN0002C2S-6U	DCR2-1.5
	1/2	FRN0003C2S-6U	DCR2-2.2
	1	FRN0005C2S-6U	DCR2-3.7

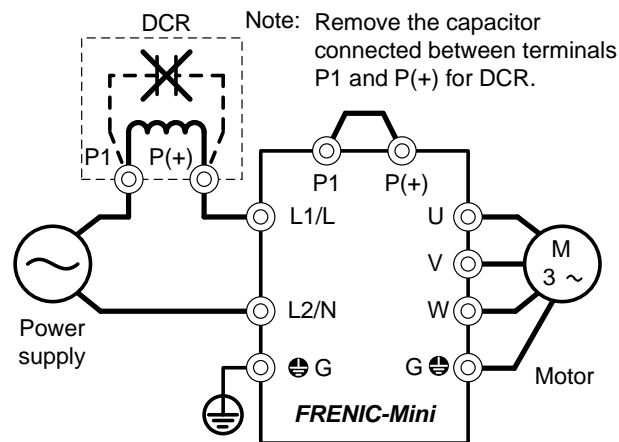

Figure 10.1 Connection Diagram of DC Reactor (DCR) (For single-phase 100 V)

Chapter 11 COMPLIANCE WITH STANDARDS

11.1 Compliance with UL Standards and Canadian Standards (cUL certification)

11.1.1 General

Originally, the UL standards were established by Underwriters Laboratories, Inc. as private criteria for inspections/investigations pertaining to fire/accident insurance in the USA. Later, these standards were authorized as the official standards to protect operators, service personnel and the general populace from fires and other accidents in the USA.

cUL certification means that UL has given certification for products to clear CSA Standards. cUL certified products are equivalent to those compliant with CSA Standards.

11.1.2 Considerations when using FRENIC-Mini in systems to be certified by UL and cUL

To use the FRENIC-Mini series of inverters as a part of UL Standards or CSA Standards (cUL certified) certified product, refer to the guidelines given below.

Conformity to UL standards and Canadian standards (cUL certification)

If installed according to the guidelines given below, inverters marked with UL/cUL are considered as compliant with the UL and CSA (cUL certified) standards.

CAUTION

Integral solid state short circuit protection does not provide branch circuit protection. Branch circuit protection must be provided in accordance with the National Electrical Code and any additional local codes.

1. Solid state motor overload protection (motor protection by electronic thermal overload relay) is provided in each model.
Adjust function codes F10 to F12 and H89 to set the protection level.
2. Connect the power supply satisfying the characteristics shown in the table below as an input power supply of the inverter. (Short circuit rating)
3. Use 75°C Cu wire only.
4. Use Class 1 wire only for control circuits.

Short circuit rating

When protected by class J fuses, suitable for use on a circuit capable of delivering not more than B rms symmetrical amperes, A volts maximum.

Power supply voltage	Inverter type	Power supply max. voltage A (Volts)	Power supply current B (Amperes)
Single-phase 100V	FRN0001C2S-6U	120 VAC	65,000 A or less
	FRN0002C2S-6U		
	FRN0003C2S-6U		
	FRN0005C2S-6U		

Conformity to UL standards and Canadian standards (cUL certification) (Continued)

⚠ CAUTION

5. Install UL certified fuses rated 600 Vac between the power supply and the inverter, referring to the table below.

Power supply voltage	Inverter type	Required torque lb-in (N·m)			Wire size AWG or kcmil (mm ²)			Class J fuse current (A)
		Main terminal	Control circuit		Main terminal ^{*3}	Control circuit		
			^{*1} TERM1	^{*2} TERM2-1 TERM2-2		^{*1} TERM1	^{*2} TERM2-1 TERM2-2	
Single-phase 100 V	FRN0001C2S-6U	10.6 (1.2)	3.5 (0.4)	1.8 (0.2)	14	20 (0.5)	6	
	FRN0002C2S-6U						10	
	FRN0003C2S-6U						15	
	FRN0005C2S-6U						30	

*1 Denotes the relay contact terminals for [30A], [30B] and [30C].

*2 Denotes control terminals except for [30A], [30B] and [30C].

*3 Values in [] mean the size (AWG) of Grounding wires if exist.

6. To comply with CSA for 100 VAC input models, transient surge suppression shall be installed on the line side of this equipment and shall be rated 120 V (phase to ground), 120 V (phase to phase), suitable for overvoltage category 3, and shall provide protection for a rated impulse withstand voltage peak of 2.5 kV.

7. Maximum surrounding air temperature rating of 50°C.

Compact Inverter
FRENIC-Mini

Instruction Manual
Supplement to Single-phase 100 V Input Series

First Edition, March 2014

Fuji Electric Co., Ltd.

The purpose of this instruction manual is to provide accurate information in handling, setting up and operating of the FRENIC-Mini series of inverters. Please feel free to send your comments regarding any errors or omissions you may have found, or any suggestions you may have for generally improving the manual.

In no event will Fuji Electric Co., Ltd. be liable for any direct or indirect damages resulting from the application of the information in this manual.