

00012



CD Automation S.r.l.

Via Picasso 34/36 - 20025 - Legnano (MI) - ITALY

Tel +39 0331 577479 - Fax +39 0331 579479

E-Mail: info@cdautomation.com - WEB: www.cdautomation.com

1 Important warnings for safety	6
2 Note	7
3 Introduction	8
4 Advantages compared with analog thyristor unit	8
5 Software Configurator CDA Thyristor configurator software	9
6 Quick Start	10
7 Basic Connections and sizing.....	11
8 Identification and Order Code	12
8.1 Identification of the unit	12
8.2 Order Code	13
9 Technical Specifications	14
9.1 General features:	14
9.2 Input features:	14
9.3 Output features(power device):	14
9.4 Fan Specification	14
9.5 Environmental installation conditions	15
9.6 Derating Curve	15
10 Installation.....	15
10.1 Dimensions and Weight	16
10.2 Fixing holes	17
11 Wiring instructions	18
11.1 Removing the cover	18
11.2 Terminals Positions	19
11.3 Power Terminals	20
11.4 Power cable torque (suggested)	21
11.5 Power cable dimensions (suggested)	21
11.6 Cable dimensions (suggested) of Earth and of the Command Terminals	22
11.7 Control Terminals on S9 (280A)	22
11.8 Schematic on S9 (280A)	23
11.9 Connection Diagram for Single-phase on S9 (280A)	24
11.10 Control Terminals on on S12 (400-700A)	25
11.11 Schematic on on S12 (400-700A)	26
11.12 Connection Diagram for Single-phase on S12 (400-700A)	27
12 Control Panel.....	28
12.1 Scroll the parameters	29
12.2 Operator Menu <i>oPEr</i>	30
12.3 Setup Menu <i>SEt</i>	33
12.4 Hardware Menu <i>HArd</i>	36
12.5 Control Panel Led	39
12.6 Displayed Alarms	39

13 Input output signal.....	40
13.1 Digital Input	40
13.1.1 ENABLE (TERMINAL 16 ON S9 , 5 ON S12).....	40
13.1.2 CONFIGURABLE INPUT (TERMINAL 15 ON S9 , 6 ON S12)	40
13.1.3 DIGITAL OUTPUT (TERMINAL 18-19-20 ON S9 , 1-2-3 ON S12)	40
13.2 Analog Input	40
PRIMARY INPUT (TERMINALS 9 AND 10 ON S9 , 11-12 ON S12).....	40
14 Heater Break alarm and SCR short circuit (HB Option).....	41
14.1 Heater break Calibration procedure	41
14.2 HB alarm contact (digital output)	41
15 Firing type.....	42
15.1 Phase Angle (PA <i>PA</i>)	42
15.2 Soft Start with Phase Angle (S+PA <i>PASt</i>)	42
15.3 Delay Triggering with Burst Firing (DT+BF <i>bFdt</i>)	43
16 Current Limit	45
16.1.1 CURRENT LIMIT SETTING	45
16.1.2 CURRENT LIMIT TUNING PROCEDURE	45
17 Feed-back type.....	46
17.1 Supply the Electronic Board	47
18 Analog Inputs.....	48
PRIMARY INPUT	48
19 RS485 Serial Port	49
20 PG Connector.....	50
21 Internal Fuse.....	51
22 Maintenance.....	52
22.1 Trouble Shooting	52
22.2 Warranty condition	52

CD Automation s.r.l.**Controllers, Drives & Automation**

Via Picasso, 34/36 - 20025 Legnano (MI)- Italia
 P.I. 08925720156 -Tel. (0331) 577479 - Fax (0331) 579479
 Internet : www.cdautomation.com - E-MAIL: info@cdautomation.com

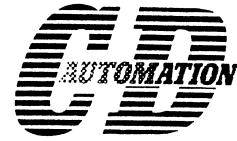

Dichiarazione di Conformità **CE** **CE** Declaration of Conformity

PRODUTTORE:
 PRODUCT MANUFACTURER: CD Automation S.R.L.

INDIRIZZO:
 ADDRESS: Via Pablo Picasso 34//36
 20025 Legnano (Mi)
 Italia

Dichiara che il prodotto:
Declare that the product:

RevoCL, 1ph da 280 a 700A

SODDISFA I REQUISITI DELLA NORMA :

Specifica di sicurezza EN60947-1 :2008
 EN60947-4-3:2001
 Specifica sulle emissioni EN60947-4-3:2000
 Specifica sulle Immunità EN60947-4-3:2000

FULFILLS THE REQUIREMENTS OF THE STANDARD:

Electrical safety Standard EN60947-1 :2008
 EN60947-4-3:2001
 Generic Emission standard EN60947-4-3:2000
 Generic Immunity standard EN60947-4-3:2000

CDAutomation dichiara che I prodotti sopra menzionati sono conformi alla direttiva
 CDAutomation declares that The products above mentioned they am conforming to the directive
EMC 2004/108/CEE e alla direttiva Bassa Tensione (low Voltage) **2006/95/CEE**

DESCIZIONE DEL PRODOTTO: Unità di controllo potenza elettrica
 PRODUCT DESCRIPTION: Electric power controll

UTILIZZO: Controllo processi termici
 SCOPE OF APPLICATION: Thermal controll process

Data di emissione: 20/04/2010
 Issued on: 20/04/2010

Amministratore Unico e
 Legale Rappresentante
Claudio Brizzi

1 Important warnings for safety

This chapter contains important information for the safety. The not observance of these instructions may result in serious personal injury or death and can cause serious damages to the Thyristor unit and to the components system included.

The installation should be performed by qualified persons.



The Thyristor unit are integral part of industrial equipments. When it is supply, the Thyristor unit is subject to dangerous tensions.

- Don't remove the protection Cover.
- Don't use these unit in aerospace applications and/ or nuclear.



The nominal current corresponds to use at temperature not superior to 45°C.

- The Thyristor unit must be mounted in vertical position and without obstruction above and below to allow a good flow ventilation.
- The hot air of one thyristor unit must not invest the unit positioned above.
- For side by side placed leave a space of 15mm between the unit.



A suitable device must ensure that the unit can be electrically isolated from the supply, this allows the qualified people to work in safety.



Protection (Protection, Protezione)

The unit have IP20 protection rating as defined by the specific international. Is necessary consider the place of installation.



Earth (Terre, Messa a terra)

For safety, the Thyristor unit with isolated heat-sink must be connected to earth. Earth impedance should be correspondent to local earth regulation. Periodically the earth efficiency should be inspected.



Electronic supply (Alimentation électronique, Alimentazione elettronica)

The electronic circuit of the Thyristor unit must be supplied by dedicated voltage for all electronic circuits and not in parallel with coil contactors, solenoids and other. It's recommended to use a shielded transformer.



Electric Shock Hazard (Risque de choque électrique, Rischi di scosse elettriche)

When the Thyristor unit is energized, after the power supply is shut off, wait least a minute for allow the discharge of the internal capacitors where there is a dangerous tension. Before working, make sure that:

- Only authorized personnel must perform maintenance, inspection, and replacement operations.
- The authorized personnel must read this manual before to have access to the unit.
- Unqualified People don't perform jobs on the same unit or in the immediate vicinities.

**Important warnings (Attention, Avvertenze importanti)**

During the operations with units under tension, local regulations regarding electrical installation should be rigidly observed:

- Respect the internal safety rules.
- Don't bend components to maintain insulation distances.
- Protect the units from high temperature humidity and vibrations.
- Don't touch components to prevent electrostatic discharges on them.
- Verify that the size is in line with real needs.
- To measure voltage current etc. on unit, remove rings and other jewels from fingers and hands.
- Authorized personnel that work on thyristor unit under power supply voltage must be on insulated board

This listing does not represent a complete enumeration of all necessary safety cautions.

**Electromagnetic compatibility****(Compatibilità elettromagnétique, Compatibilità elettromagnetica)**

Our thyristor units have an excellent immunity to electromagnetic interferences if all suggestions contained in this manual are respected. In respect to a good Engineering practice, all inductive loads like solenoids contactor coils should have a filter in parallel.

**Emissions (Emission, Emissioni)**

All solid-state power controllers emit a certain amount of radio-frequency energy because of the fast switching of the power devices.

The CD Automation's Thyristor unit are in accord with the EMC norms, CE mark.

In most installations, near by electronic systems will experience no difficulty with interference. If very sensitive electronic measuring equipment or low-frequency radio receivers are to be used near the unit, some special precautions may be required. These may include the installation of a line supply filter and the use of screened (shielded) output cable to the load.

2 Note



Warning: This icon is present in all the operational procedures where the Improper operation may result in serious personal injury or death



Caution: This icon is present in all the operational procedures where the Improper operation can cause damage for the Thyristor unit.

CD Automation reserves the right to modify the own products and this manual without any advise.



3 Introduction

A thyristor unit is semiconductor device which acts as a switch formed by two thyristors in antiparallel. To switch on the alternating current the input signal will be on and the thyristor will switch off at first Zero Crossing voltage with no input signal.

The benefits of thyristor units compared with electromechanical contactors are numerous: no moving parts, no maintenance and capacity to switch very fast. Thyristors are the only solution to control transformers and special loads that change resistance with temperature and with age.

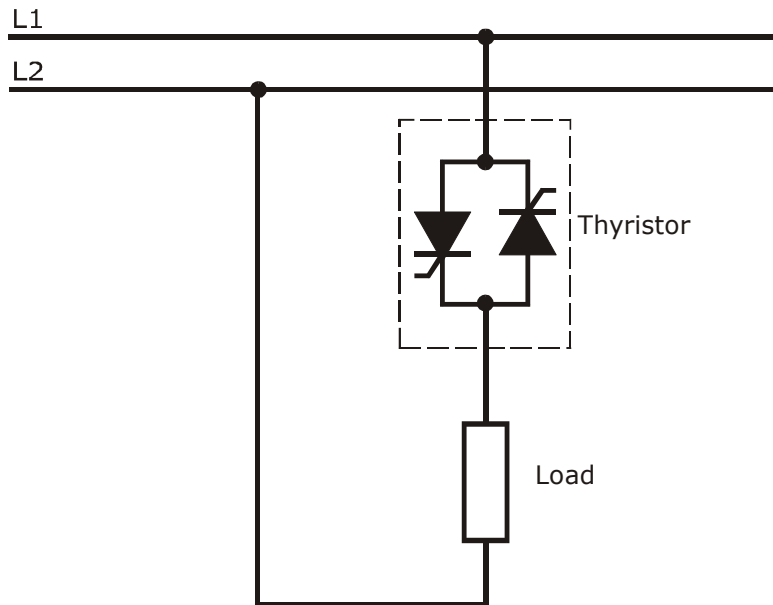

4 Advantages compared with analog thyristor unit

Communication RS485 is a standard feature of REVO CL this allows the use of many information like: current, power, load state and all the parameters for diagnostic and configuration. Ulterior advantages of the digital system vs the analogical is the flexibility and the possibility of implement special characteristics without change the hardware. Several strategies can be implemented and selected through the configuration parameters.

With CDA software configuration, you can have access to the configuration parameters. To connect the Thyristor unit to the computer use the USB\TTL converter.



5 Software Configurator CDA Thyristor configurator software

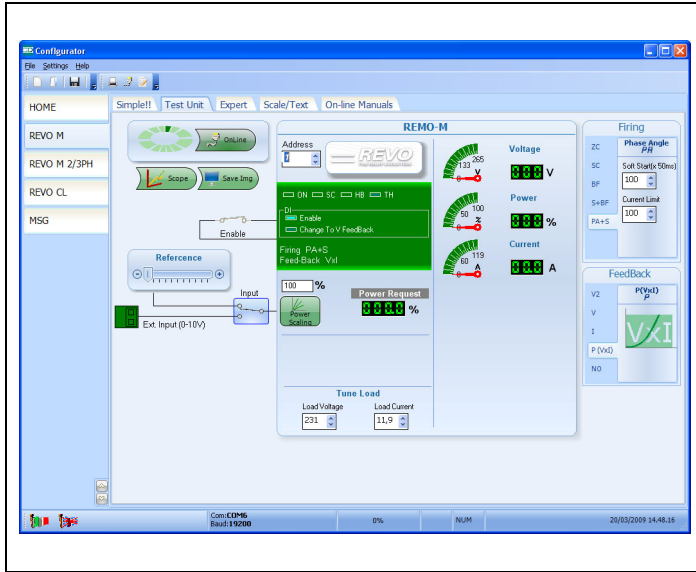

CDA Thyristor configurator software is free and is possible download it from our site: www.cdautomation.com

If the Order Code is in line with requirement, then REVO CL has been already configured in Factory and it's ready to use. You need the software only to modify the ordered configuration. Anyway we suggest to check the unit on the machine with the "Test unit" section.

For install the software, launch the program and follow the instructions on the screen.

Run the software configurator and set the serial port of the PC with con baudrate =19200(default) and the address of Thyristor unit (default=1).



To connect the unit at the PC, it's necessary use the USB\TTL converter connected between the unit and the USB port of the PC.

USB\TTL converter need a driver to work properly, you can find it at www.cdautomation.com

Is available a full programmer kit composed by

- USB\TTL converter,
- Two cable
- CDA Thyristor configurator software
- USB driver



With the CD-RS serial converter is possible configure the Thyristor unit also through the RS485 For this solution, the programming cable is not necessary.

6 Quick Start



Attention: this procedure must be carried out by skilled people only.

If your REVO CL code is in line with what you really need, then the main configuration is already done by CD Automation and you just need to do the following steps:

1. Verify REVO CL's current sizing. Be sure that:
 - the load current is equal or less than the nominal one of REVO CL
 - the main voltage is equal or less than the nominal voltage of REVO CL
2. Verify the Installation
3. Verify the Wiring:
 - all auxiliary connections must be done in line with wirings on this manual
 - verify that there isn't a short circuit on the load
4. Supply the auxiliary voltage of the unit
Set the parameters U_OP (Operative Voltage) and A_Lo (Nominal Current of the load) using the frontal keypad or CDA Thyristor configurator software.

	U_{OP}	Operative Voltage	V	R/W
Function:		It's necessary to specify the operative voltage		
Min/Max:		24 ÷ 1000V		
Default:		230		
Note:		With voltage up to 330V and over 600V, REVO CL needs hardware modifications: specify this in phase of ordination.		
	A_{Lo}	Load nominal current	A	R/W
Function:		It's necessary to specify the load current value at nominal voltage. This current and voltage value are necessary to be able to read the power in engineering units		
Min/Max:		1 ÷ 100.0 Ampere (for size up to 100A)		
Default:		Nominal REVO CL current value if load current has not been specified.		

If your REVO CL code is NOT in line with what you really need, use the enclosed configurator software tool to set-up the unit. Install the software on your PC, select REVO CL and click on test unit changing what you need.

7 Basic Connections and sizing

Single phase wiring with resistive load (with REVO CL-1PH)

$$I = \frac{P}{V}$$

V = Nominal voltage of the load

I = Nominal current of the load

P = Nominal power of the load

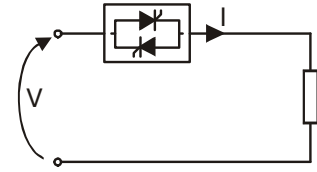

Single phase wiring with inductive load (with REVO CL-1PH)

$$I = \frac{P}{V \cos \phi}$$

V = Nominal voltage phase to phase

I = Nominal current to the load

P = Nominal power to the load

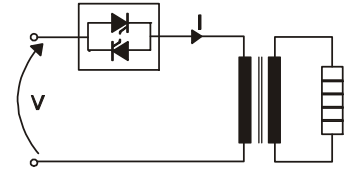

Open Delta wiring with resistive load (with 3 X REVO CL-1PH)

$$I = \frac{P}{3V}$$

V = Nominal voltage of the load

I = Nominal current of the load

P = Nominal power of the load

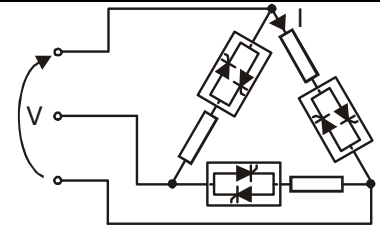

8 Identification and Order Code

8.1 Identification of the unit



Caution: Before to install, make sure that the Thyristor unit have not damages. If the product has a fault, please contact the dealer from which you purchased the product.

The identification's label give all the information regarding the factory settings of the Thyristor unit, this label is on the unit, like represented in figure.

Verify that the product is the same thing as ordered .



8.2 Order Code

Note 1

1	2	3	4	5	6	7	8	9	10	11	12	13	14	15	16
R	C	L	-	-	-	-	-	-	-	-	-	-	-	-	-

REVO CL 1PH

4, 5, 6 Current	
Description code	Numeric code
280A	2 8 0
400A	4 0 0
500A	5 0 0
600A	6 0 0
700A	7 0 0

7 Max Voltage	
Description code	Numeric code
480V	4
600V	6
690V (2)	7

8 Aux. Voltage supply	
Description code	Numeric code
90:130V (3)	1
170:265V (3)	2
230:345V (3)	3
300:530V (3)	5
510:690V (3)	6
600:760V (3)	7

9 Input	
Description code	Numeric code
SSR	S
0:10V dc	V
4:20mA	A
10KPot	K
RS485	R

10 Firing	
Description code	Numeric code
Delayed Triggering + Burst Firing DT+BF	D
Phase Angle PA	P
Soft Start + Phase Angle S+PA	E

11 Control Mode	
Description code	Numeric code
Open Loop	0
Voltage Feed Back V	U
Power Feed Back VxI	W
Voltage Square f/b V ²	Q
Current Feed Back I	I

12 Fuse & Option	
Description code	Numeric code
Fixed Fuses +CT	Y
Fixed Fuses +CT +HB	H

13 Fan Voltage	
Description code	Numeric code
Fan 110V	1
Fan 220V Std Version	2

14 Approvals	
Description code	Numeric code
CE EMC For European Market	0
cUL For American Market, Pending	L

15 Manual	
Description code	Numeric code
None	0
Italian Manual	1
English Manual	2
German Manual	3
French Manual	4

16 Version	
Description code	Numeric code
Std with fixed Fuses	1

LEGEND

CT = Current Transformer

HB = Heater Break Alarm

Note (1): After 16th digit write current and voltage of load inside brackets Ex. (400A-400V)

Note (2): Available on unit ≥400A

Note (3): Load voltage must be included in Selected Auxiliary Voltage Range

9 Technical Specifications

9.1 General features:

Cover and Socket material:	PolymericV2
Utilization Category	AC-51 AC-55a AC-55b AC-56A
IP Code	20
Method of Connecting	Single Phase Load
Auxiliary voltage:	90:130V (10 VA Max) 170:265V (10 VA Max) 230:345V (10 VA Max) 300:530V (10 VA Max) 510:690V (10 VA Max) 600:760V (10 VA Max)
Relay output for Heater Break Alarm (only with HB option):	0.5A a 125VAC



9.2 Input features:

Logic input SSR:	4 ÷ 30Vdc 5mA Max (ON ≥ 4Vdc OFF < 1Vdc)
Analogic input	0 ÷ 10Vdc impedance 15 K ohm
Analogic input	4 ÷ 20mA impedance 100 ohm
POT	10 K ohm min.
Digital Input	4 ÷ 24Vdc 5mA Max (ON ≥ 4Vdc OFF < 1Vdc)

9.3 Output features(power device):

Current (A)	Nominal Voltage range (Ue) (V)	Repetitive peak reverse voltage (Uimp)		Latching current (mAeff)	Max peak one cycle (10msec.) (A)	Leakage current (mAeff)	I ² T value max tp=10msec c	Frequency range (Hz)	Power loss I=Inom (W)	Isolation Voltage (Ui) Vac
		(480V)	(600V)							
280	24÷600	1400	1600	200	7000	15	236000	47÷70	280	2500
400	24÷600	1200	1600	200	7800	15	300000	47÷70	397	2500
500	24÷600	1200	1600	200	8000	15	306000	47÷70	530	2500
600	24÷600	1200	1600	1000	17800	15	1027000	47÷70	589	2500
700	24÷600	1200	1600	1000	17800	15	1027000	47÷70	712	2500

9.4 Fan Specification

Size		 Number of fans	 US LISTED Number of fans
S9	280A	One Fan - 17W	One Fan - 17W
S12	400A, 500A, 600A	One Fan - 17W	Two Fans - 34W
S12	700A	Two Fans - 34W	Two Fans - 34W

9.5 Environmental installation conditions

Ambient temperature	0-40°C at nominal current. Over 40°C use the derating curve.
Storage temperature	-25°C a 70°C
Installation place	Don't install at direct sun light, where there are conductive dust, corrosive gas, vibration or water and also in salty environmental.
Altitude	Up to 1000 meter over sea level. For higher altitude reduce the nominal current of 2% for each 100m over 1000m
Humidity	From 5 to 95% without condense and ice
Pollution Level	Up to 2nd Level ref. IEC 60947-1 6.1.3.2

9.6 Derating Curve

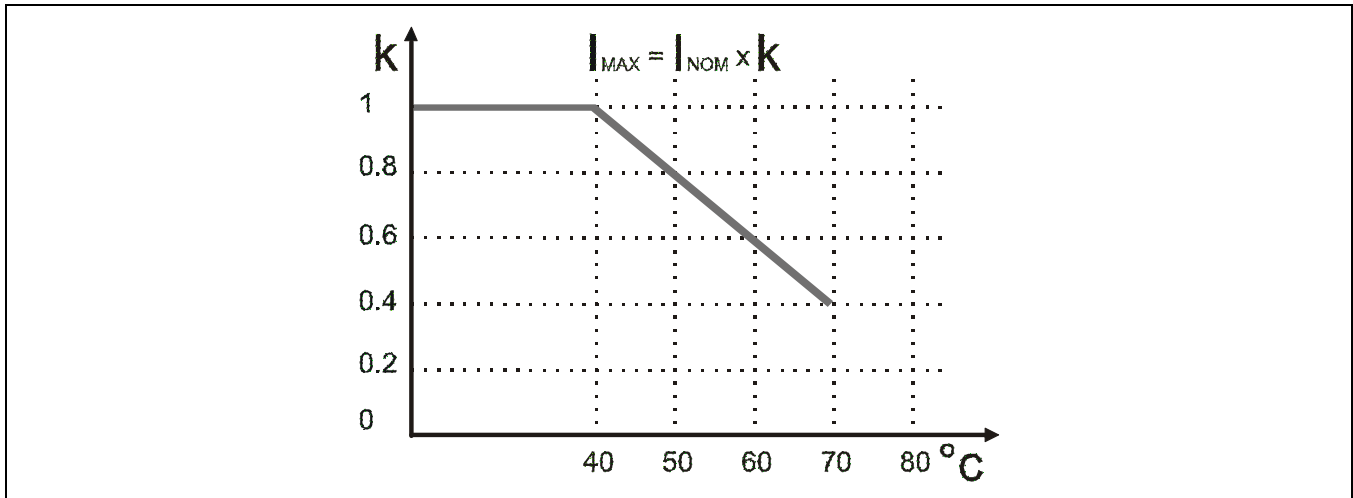

10 Installation

Before to install, make sure that the Thyristor unit have not damages.

If the product has a fault, please contact the dealer from which you purchased the product. Verify that the product is the same thing as ordered.

The Thyristor unit must be always mounted in vertical position to improve air cooling on heat-sink.

Maintain the minimum distances in vertical and in horizontal as represented.

When more unit has mounted inside the cabinet maintain the air circulation like represented in figure.

Sometimes is necessary installing a fan to have better air circulation.

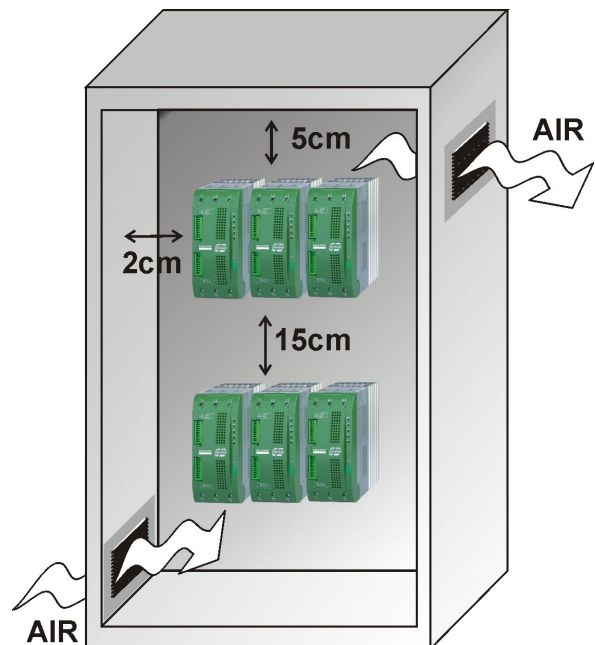

10.1 Dimensions and Weight

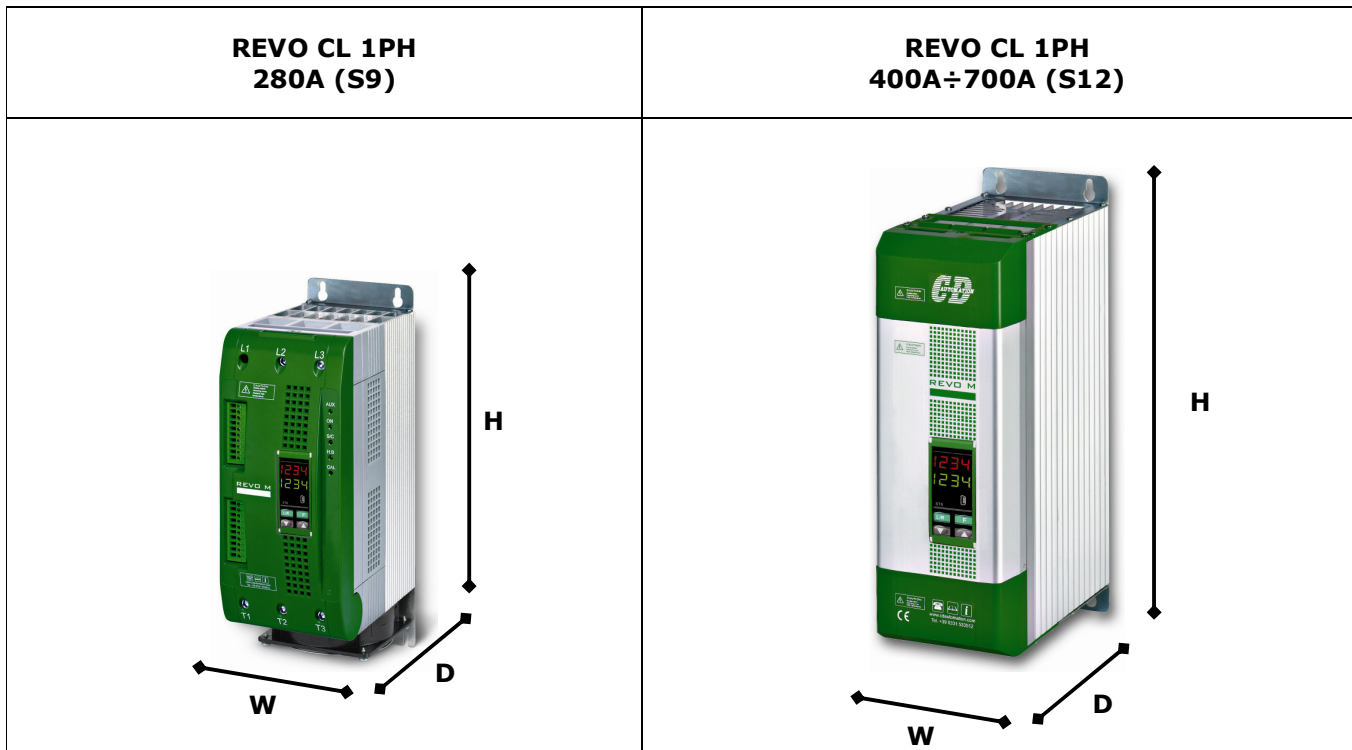

Size	W(mm)	H(mm)	D(mm)	Weight (kg)
280A (S9)	120	350	230	5,5
400A (S12)	137	520	270	15
500A (S12)	137	520	270	15
600A (S12)	137	520	270	15
700A (S12)	137	520	270	15

10.2 Fixing holes

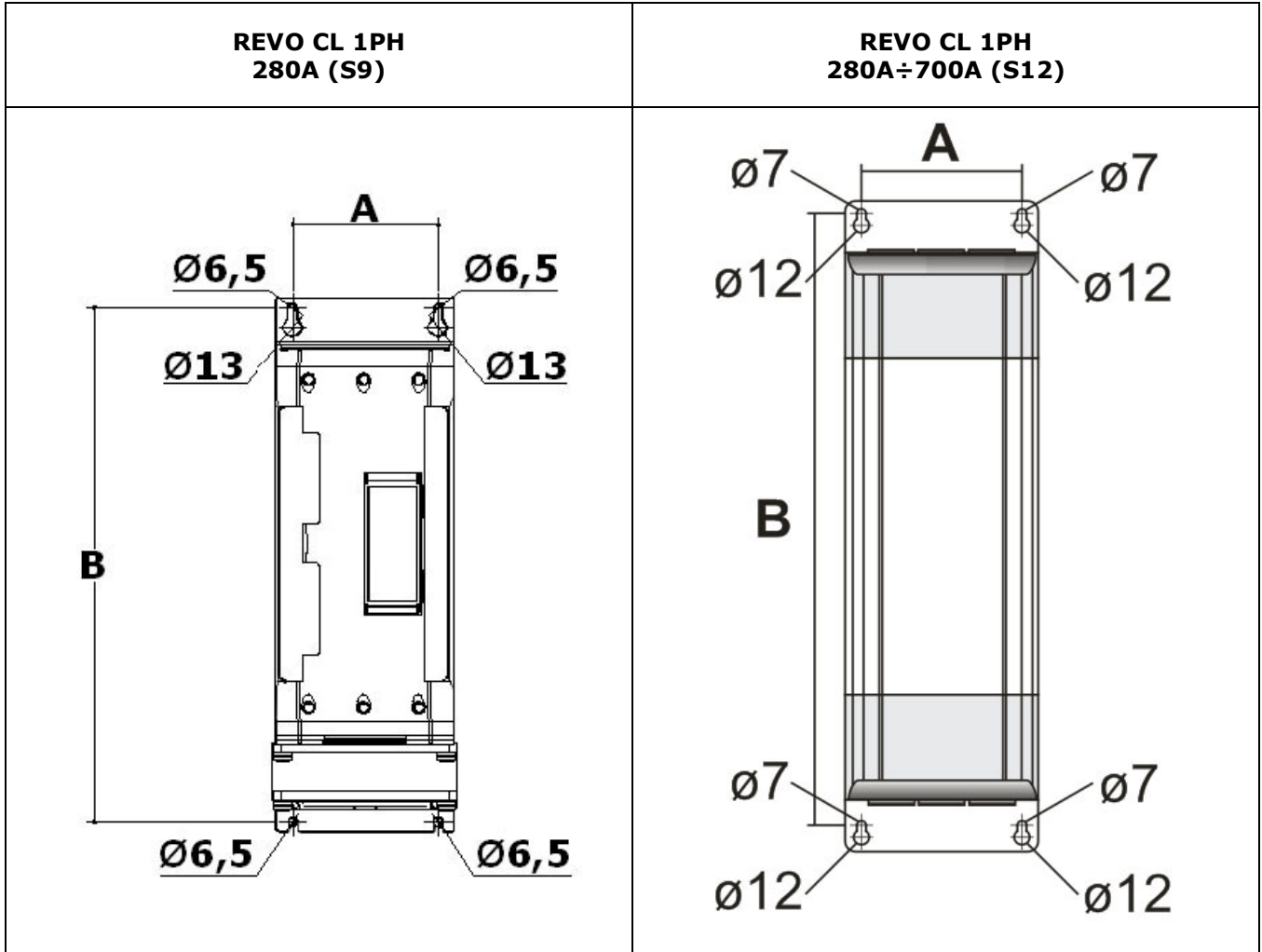

Size	A(mm)	B(mm)
280A (S9)	95	335
400A (S12)	97	490
500A (S12)	97	490
600A (S12)	97	490
700A (S12)	97	490

11 Wiring instructions

The Thyristor unit could be susceptible to interferences lost by near equipments or by the power supply, for this reason in accord to the fundamental practices rules is opportune take some precautions:

- The coil contactor, the relays and other inductive loads must be equipped with opportune RC filter.
- Use shielded bipolar cables for all the input and output signals.
- The signal cables must not be near and parallel to the power cables.
- Local regulations regarding electrical installation should be rigidly observed.

Use copper cables and wires rated for use at 75°C only.

11.1 Removing the cover

Instructions for open the thyristor unit size S9



Instructions for open the thyristor unit size S12



11.2 Terminals Positions

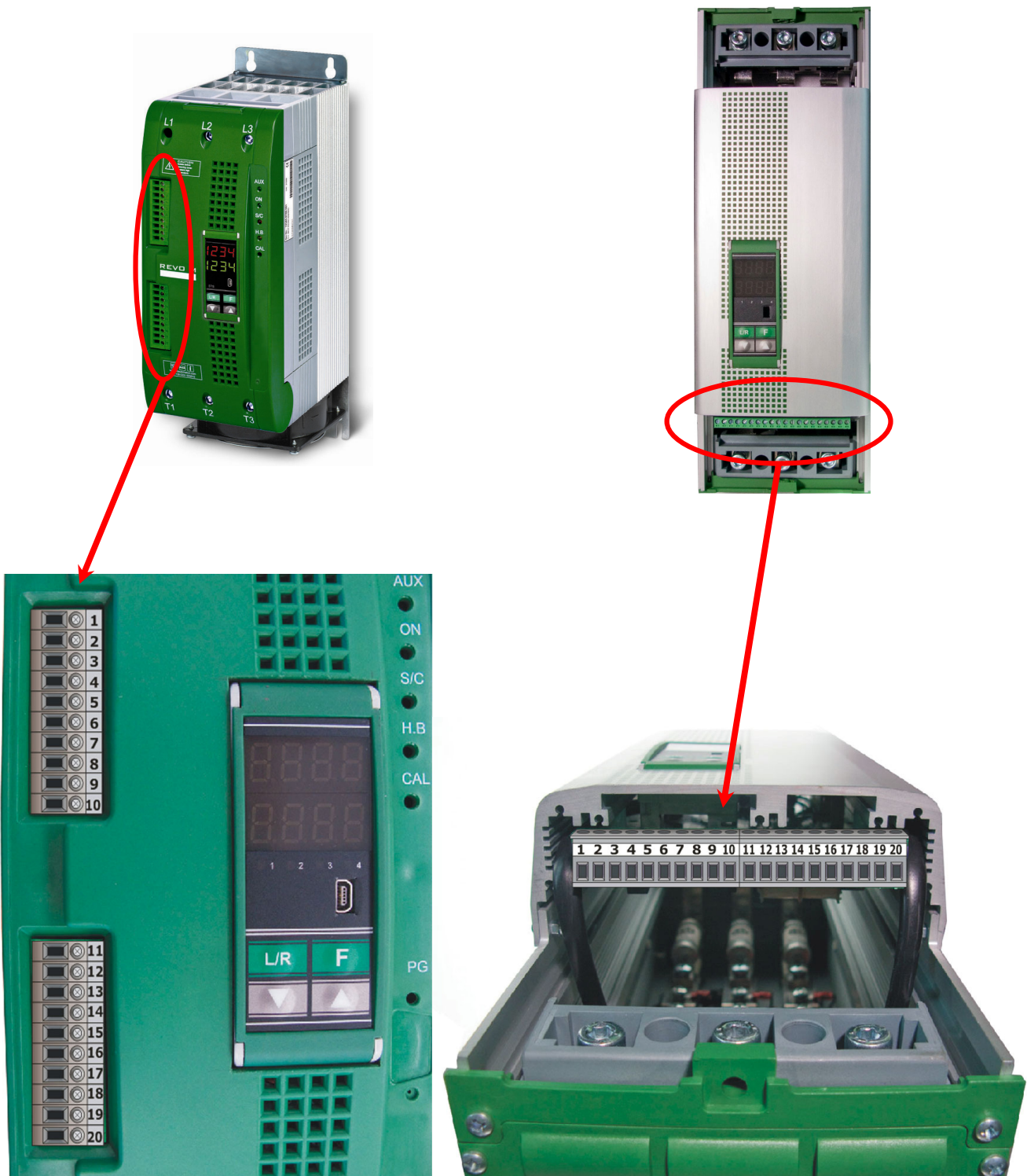

11.3 Power Terminals



Warning: Before connecting or disconnecting the unit check that power and control cables are isolated from voltage sources.

Terminal	Description
L1	Line Input Phase 1
T1	Load Output Phase 1

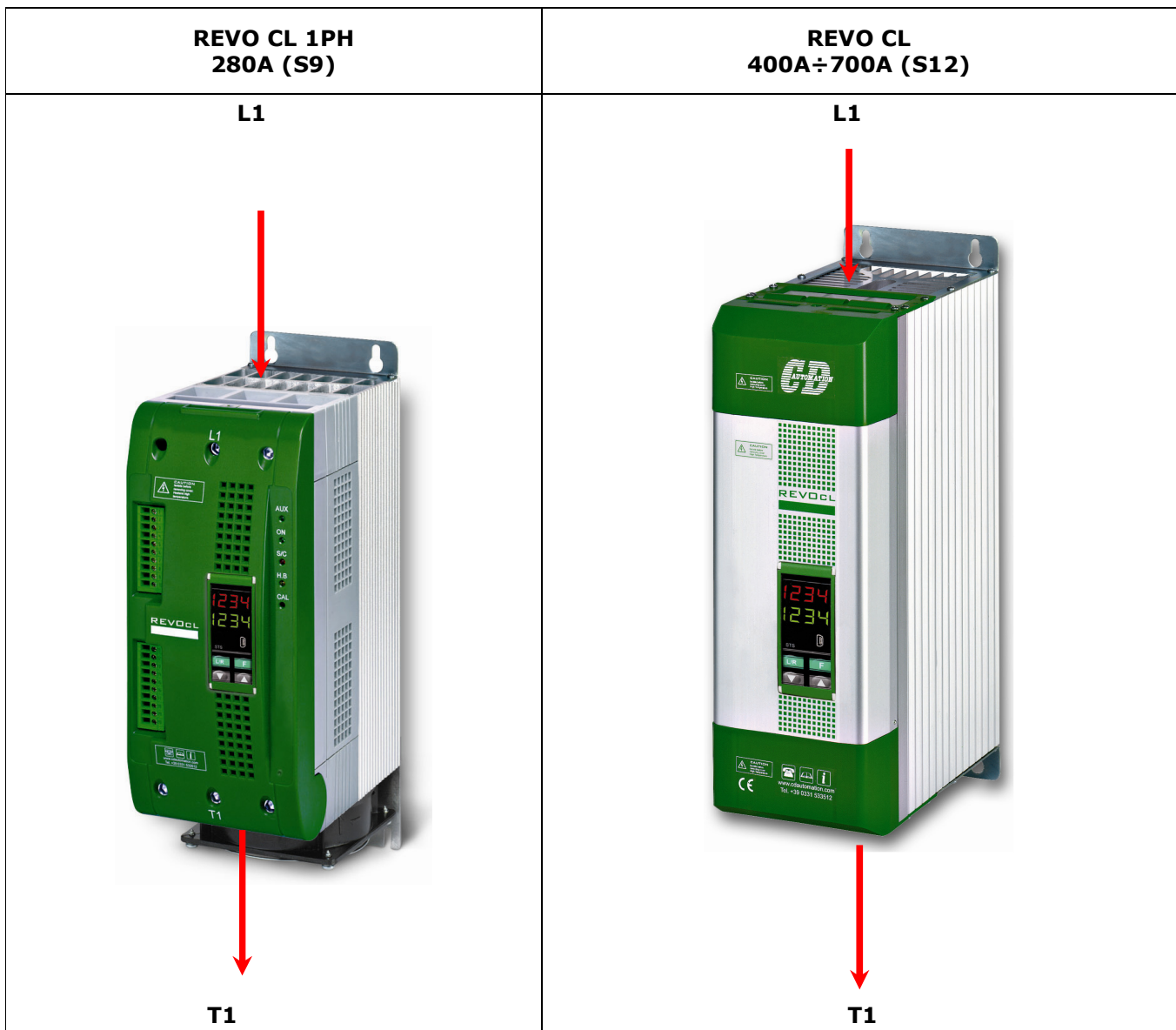

11.4 Power cable torque (suggested)

Current	Connector Type	Torque Lb-in (N-m)	Wire Range AWG / kcmil	Wire Terminal
280 A	Terminal Block M8	265 (30.0)	1 3/0	Copper wire Compact (Solid) Stranded
400A	Bus Bar with M10 screw	505 (57.0)	2x3/0 600	UL Listed (ZMVV) Copper Tube Crimp. Lug
500A	Bus Bar with M10 screw	505 (57.0)		Bus bar 60x4mm
600A	Bus Bar with M10 screw	505 (57.0)		Bus bar 60x5mm
700A	Bus Bar with M10 screw	505 (57.0)		Bus bar 60x6mm

11.5 Power cable dimensions (suggested)

Current	Supply			Load		
	Cable		Screw	Cable		Screw
	mm²	AWG		mm²	AWG	
280A (S9)	95	3/0	M8	95	3/0	M8
400A (S12)	2 x 95	2 x 3/0	M10	2 x 95	2 x 3/0	M10
500A (S12)	Bus Bar		60 x 4 mm	Bus Bar		60 x 4 mm
600A (S12)	Bus Bar		60 x 5 mm	Bus Bar		60 x 5 mm
700A (S12)	Bus Bar		60 x 6 mm	Bus Bar		60 x 6 mm

11.6 Cable dimensions (suggested) of Earth and of the Command Terminals

Current	Earth			Command Terminals		
	Cable		Screw M	Cable		
	mm ²	AWG		mm ²	AWG	
280A (S9)	25	4	M6	0,50	18	
400A (S12)	50	1	M8	0,50	18	
500A (S12)	70	1/0	M8	0,50	18	
600A (S12)	70	1/0	M8	0,50	18	
700A (S12)	70	1/0	M8	0,50	18	

11.7 Control Terminals on S9 (280A)



Warning: Before connecting or disconnecting the unit check that power and control cables are isolated from voltage sources.

Terminal	Description
1	Aux – Voltage Supply for electronic boards and synchronization (See order code for the Value)
2	Not Connected
3	Aux – Voltage Supply for electronic boards and synchronization (See order code for the Value)
4	Not Connected
5	Fan supply voltage (230V standard – 115V option)
6	Fan supply voltage (230V standard – 115V option)
7	Not Connected
8	COM I - Common Digital Input
9	+ Control Input (SSR/0-10Vdc/4-20mA)
10	- Control Input (SSR/0-10Vdc/4-20mA)

Terminal	Description
11	0V GND
12	Output +10Vdc stabilized 1 mA MAX
13	RS485 B
14	RS485 A
15	DI 1 - Configurable Input
16	DI 2 - Enable Digital Input
17	+ Ext CL - External Current Profiler
18	NC - Normally Close contact alarm relay output (HB)
19	C - Common contact alarm relay output
20	NO - Normally Open contact alarm relay output (HB)

11.8 Schematic on S9 (280A)



Caution: this procedure must be performed only by qualified persons.

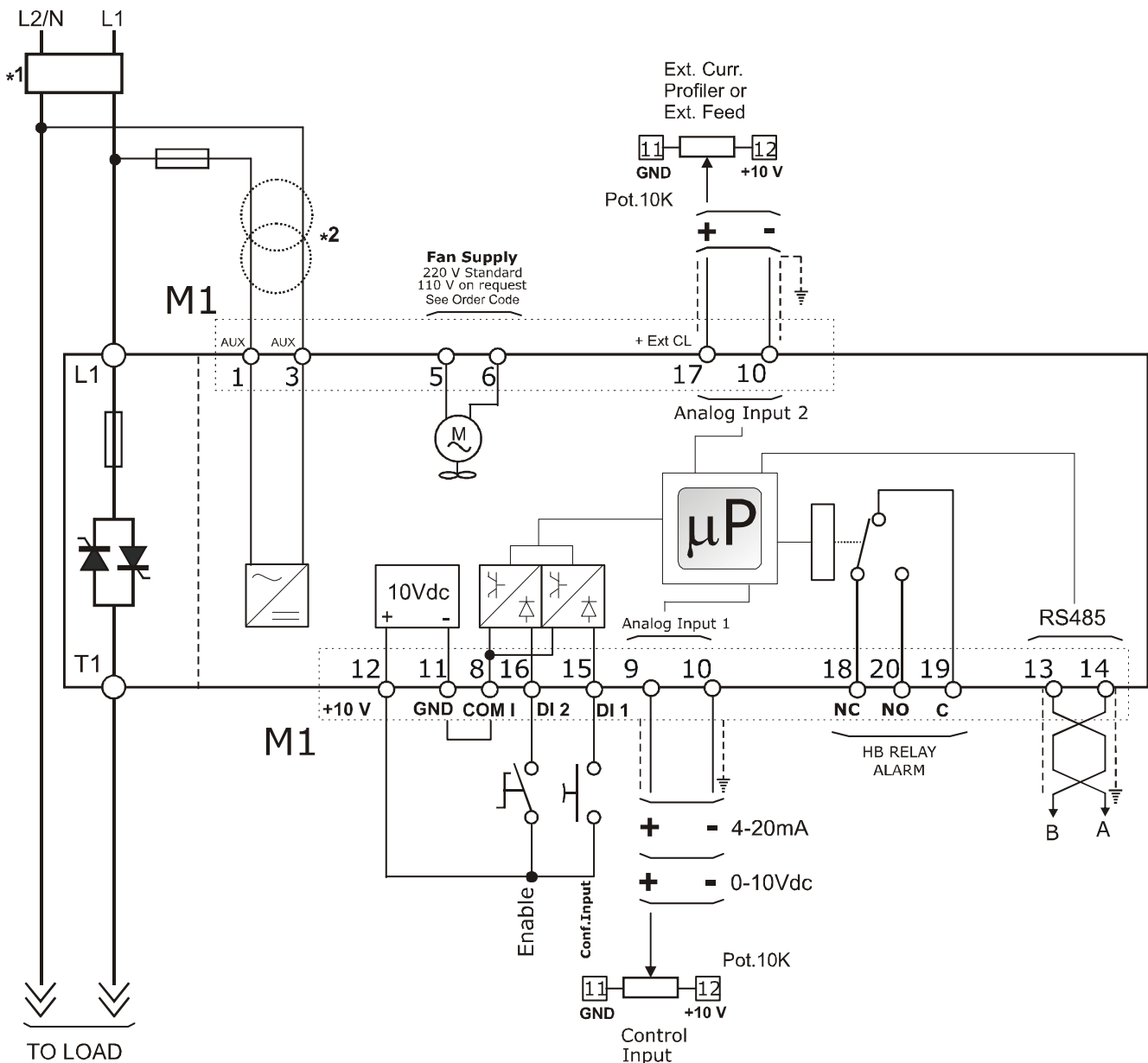

NOTE:

- *1 The user installation must be protecting by electromagnetic circuit breaker or by fuse isolator. The semiconductor I2t should be 20% less than power controller I2t. Semiconductor fuses are classified for UL as supplemetar protection for semiconductor. They are note approved for branch circuit protection.
- *2 The auxiliary voltage supply of the Revo CL unit must be synchronized with load voltage power supply. If the Auxiliary Voltage (written on the identification label) is different from Supply Voltage (to the load), use an external transformer as designated.

11.9 Connection Diagram for Single-phase on S9 (280A)



Caution: this procedure must be performed only by qualified persons.

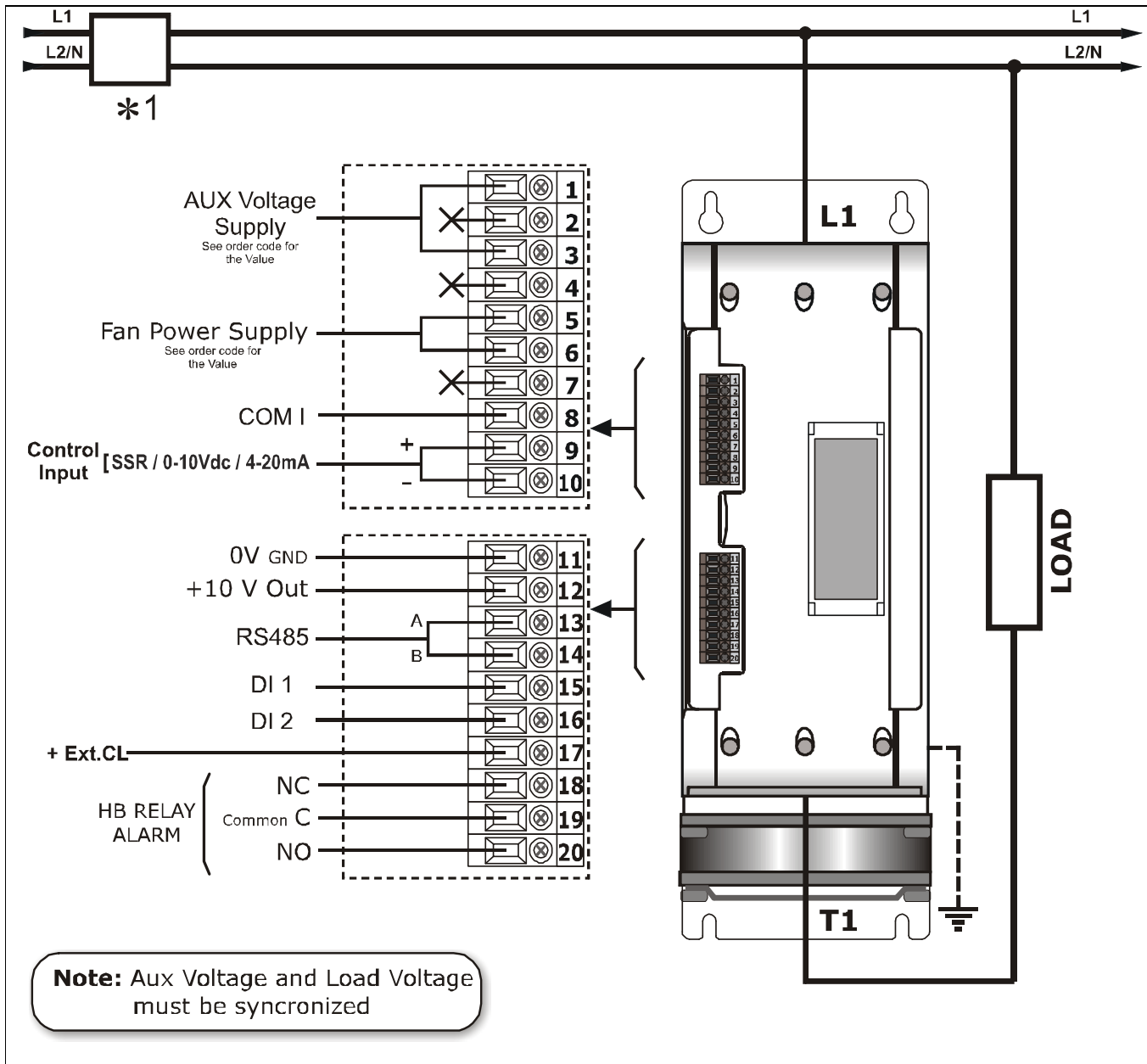

X = not connected

*1 The user installation must be protecting by electromagnetic circuit breaker or by fuse isolator. The semiconductor I2t should be 20% less than power controller I2t. Semiconductor fuses are classified for UL as supplementar protection for semiconductor.

11.10 Control Terminals on on S12 (400-700A)

Warning: Before connecting or disconnecting the unit check that power and control cables are isolated from voltage sources.

Terminal	Description
1	NO - Normally Open contact alarm relay output (HB)
2	C - Common contact alarm relay output
3	NC - Normally Close contact alarm relay output (HB)
4	+ Ext CL - External Current Profiler
5	DI 2 - Enable Digital Input
6	DI 1 - Configurable Input
7	RS485 A
8	RS485 B
9	Output +10Vdc stabilized 1 mA MAX
10	0V GND

Terminal	Description
11	- Control Input (SSR/0-10Vdc/4-20mA)
12	+ Control Input (SSR/0-10Vdc/4-20mA)
13	COM I - Common Digital Input
14	Not Connected
15	Fan supply voltage (230V standard - 115 option)
16	Fan supply voltage (230V standard - 115 option)
17	Not Connected
18	Aux - Voltage Supply for electronic boards and sincronization (See order code for the Value)
19	Not Connected
20	Aux - Voltage Supply for electronic boards and sincronization (See order code for the Value)

11.11 Schematic on on S12 (400-700A)



Caution: this procedure must be performed only by qualified persons.

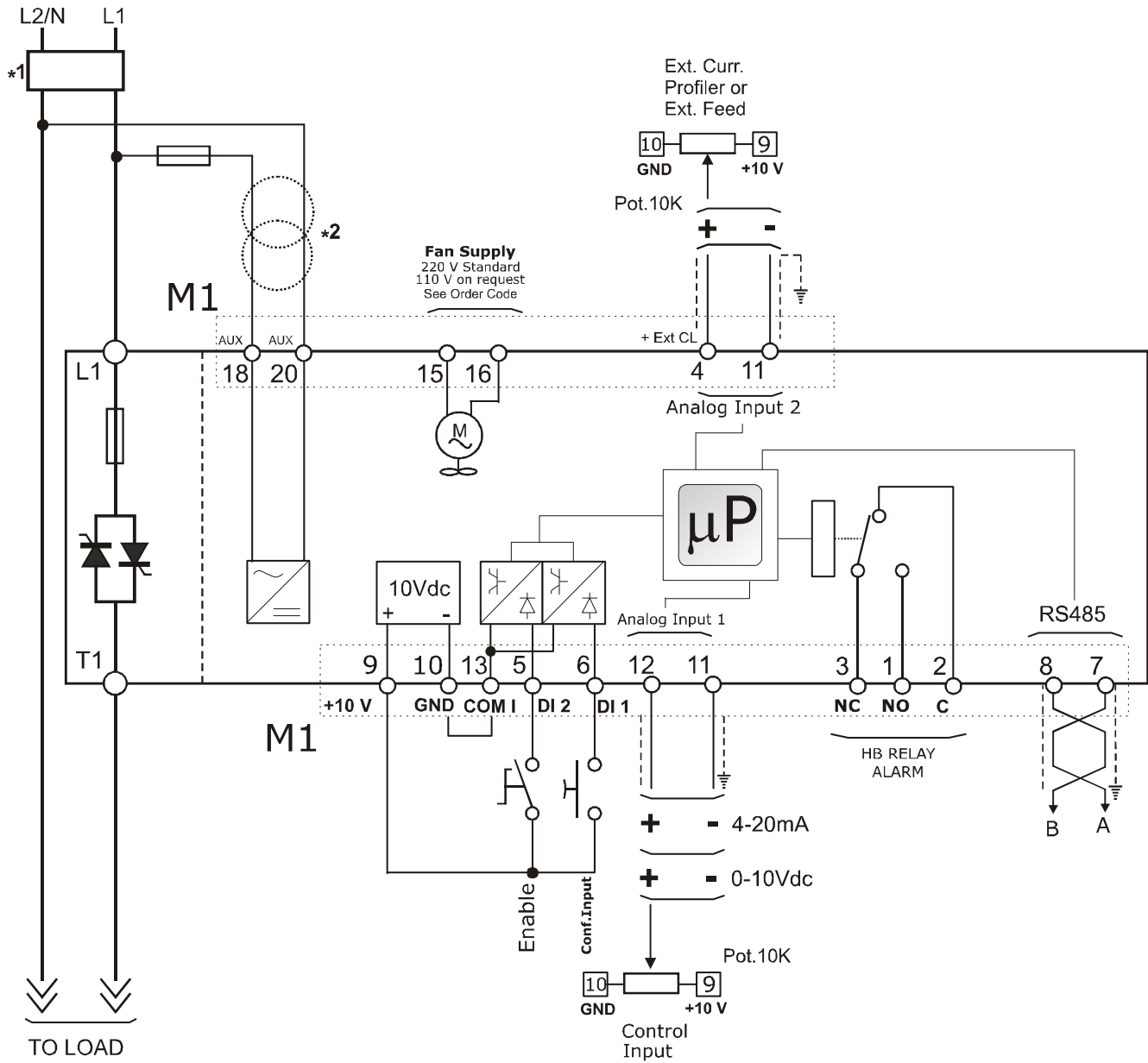

NOTE:

- *1 The user installation must be protecting by electromagnetic circuit breaker or by fuse isolator. The semiconductor I2t should be 20% less than power controller I2t. Semiconductor fuses are classified for UL as supplemetar protection for semiconductor. They are note approved for branch circuit protection.
- *2 The auxiliary voltage supply of the Revo CL unit must be synchronized with load voltage power supply. If the Auxiliary Voltage (written on the identification label) is different from Supply Voltage (to the load), use an external transformer as designated.

11.12 Connection Diagram for Single-phase on S12 (400-700A)

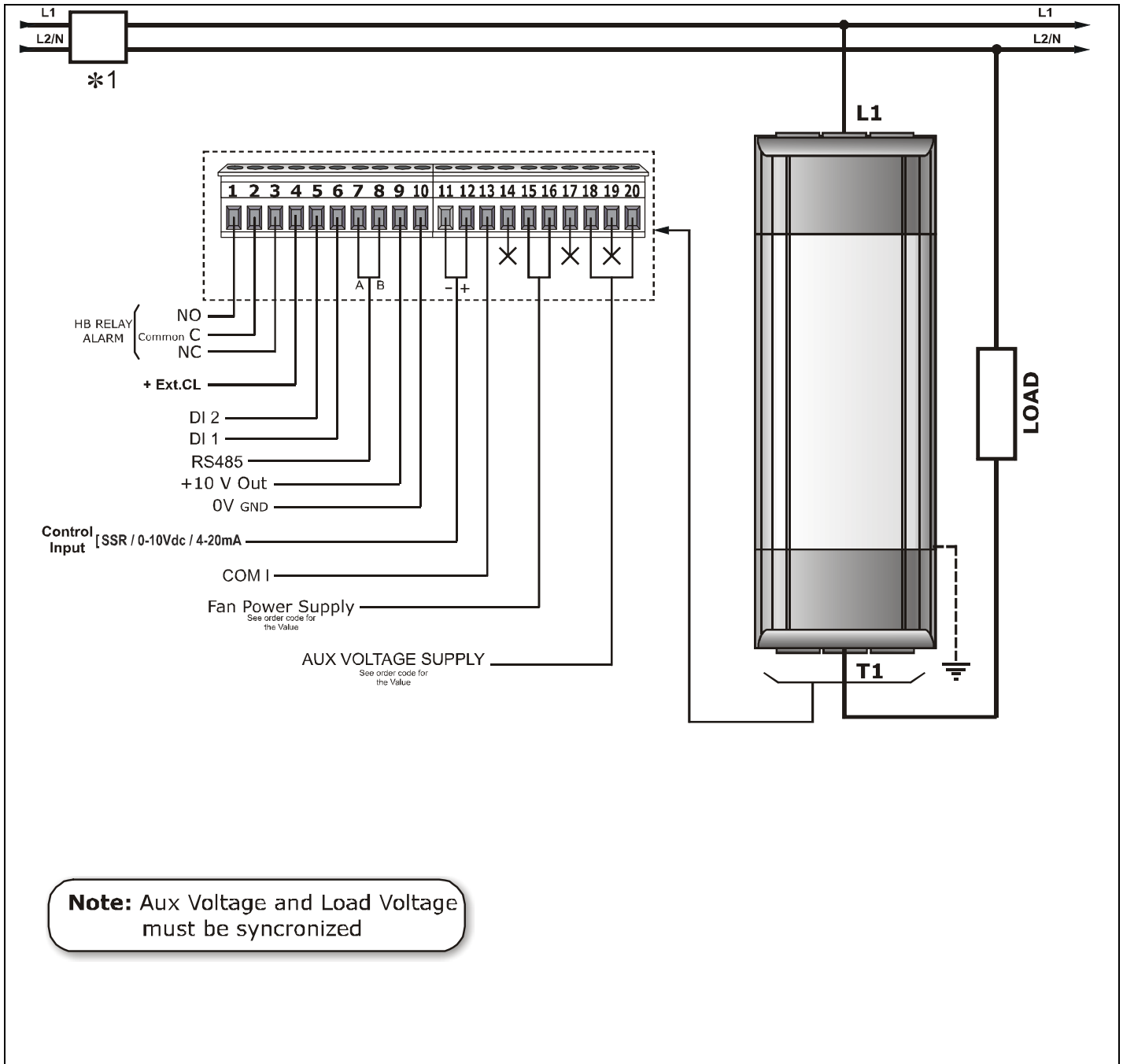

X = not connected

*1 The user installation must be protecting by electromagnetic circuit breaker or by fuse isolator. The semiconductor I2t should be 20% less than power controller I2t. Semiconductor fuses are classified for UL as supplementar protection for semiconductor.

12 Control Panel

The Control Panel is placed on the front of the thyristor unit, on his display you can visualize the alarms, the input and output signals and all the configuration parameters .

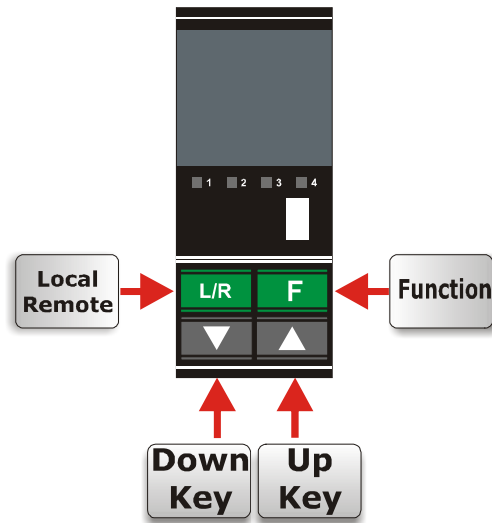

The function keys are the following:

- The **Function key F** is used to scroll the parameter *A U P*.
- The **UP key and DOWN key** are used to set the parameters in the menu and to change data.
- The **L/R key** is used to edit the parameters and to save the modified values.
- The **F+L/R** is used for enter and exit from the menu.

The Control Panel have three menu, and to enter in one of them you must set correctly the parameter *PASS* :

- Operator Menu (*PASS* = 2)
This menu contains a reading parameters that give information on the state of the unit, it include also the base parameters for quick start, like the value of current and voltage load and the Set-point data.
- Hardware Menu (*PASS* = 5)
This menu contains all the configuration parameters for analogic and digital I/O, and the parameters to set the serial port like the address and the baudrate.
- Setup Menu (*PASS* = 10)
This menu contains all the setting parameters to configure the thyristor unit, like the firing type, the current limit, [ecc].

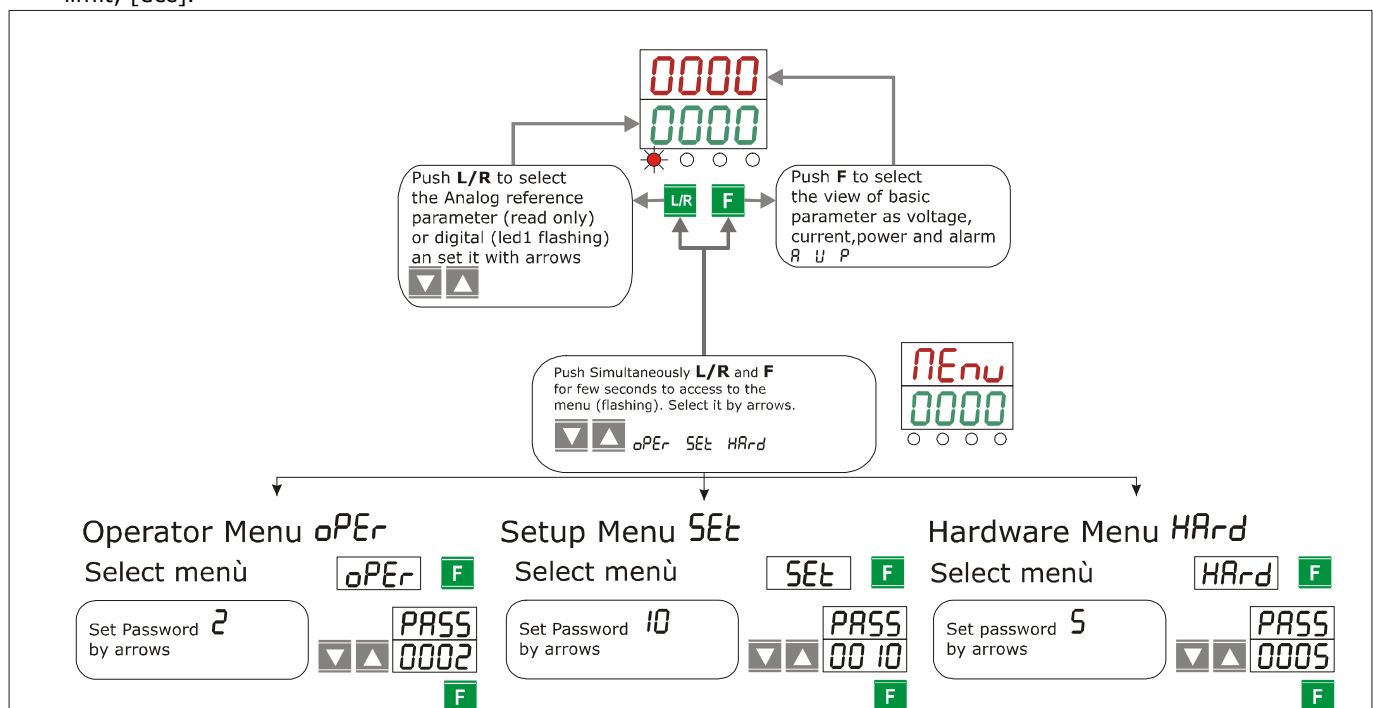

12.1 Scroll the parameters

Operator Menu <i>oPEr</i>	Setup Menu <i>SEt</i>	Hardware Menu <i>HArd</i>
<p>F ▼ ▲ Digital Set Point F L/R SP</p>	<p>F ▼ ▲ Set Firing type F F_{ir}</p>	<p>F ▼ ▲ Set analog input type F A_{in}</p>
<p>F ▼ ▲ Set Max Output F out_n</p>	<p>F ▼ ▲ Ramp up settings. Only $F_{ir}=PR$ F rP_u</p>	<p>F ▼ ▲ Set Min. Value Input 1. F L_{IA1}</p>
<p>F Read Power Output F P</p>	<p>F ▼ ▲ Set HB Sensitivity F Hb_S</p>	<p>F ▼ ▲ Set Max. Value Input 1 F H_{IA1}</p>
<p>F ▼ ▲ Current Limit F CL</p>	<p>F ▼ ▲ Set HB Delay F Hb_d</p>	<p>F ▼ ▲ Set Digital Input 1 F Cd₁₁</p>
<p>F Read Current Output F A</p>	<p>F ▼ ▲ Set FeedBack type F FEEd</p>	<p>F ▼ ▲ Set Digital Input 2 F Cd₁₂</p>
<p>F Read average voltage Output F U_{out}</p>	<p>F ▼ ▲ Set cycle Burst Firing. Only $F_{ir}=bFdE$ F bf_n</p>	<p>F ▼ ▲ Set Digital Output 1 F Cdo₁</p>
<p>F ▼ ▲ Set Load Voltage F U_{oP}</p>	<p>F ▼ ▲ Set Delay Triggering only $F_{ir}=bFdE$ F dt</p>	<p>F ▼ ▲ Serial Port Baud Rate F bAud</p>
<p>F ▼ ▲ Set Load Current F A_{Lo}</p>	<p>F ▼ ▲ Set Load Type F LoAd</p>	<p>F ▼ ▲ Serial Port Address F Addr</p>
<p>F Digital input 1 Value F d₁₁</p>	<p>F ▼ ▲ Set Proportional Band F Pb</p>	<p>F ▼ ▲ Current Limit Mode $F_{ir}=PR$ F CL₁</p>
<p>F Digital input 2 Value F d₁₂</p>	<p>F ▼ ▲ Set Integral Time F t_i</p>	<p>To exit from the menu push a long time both L/R F</p>
<p>F Analogic\Dig. Value F A_d</p>	<p>F ▼ ▲ Start up displayed parameter F StPr</p>	
<p>F ▼ ▲ Unit Enable Value F EnAb</p>	<p>F ▼ ▲ Option not used F rtPr</p>	
<p>To exit from the menu push a long time both L/R F</p>	<p>To exit from the menu push a long time both L/R F</p>	

12.2 Operator Menu *oPEr*

- Push simultaneously **L/R** and **F** for few seconds to **access** to the menu (*Menu* flashing).
- Select by arrows **UP** and **DOWN** : *oPEr* then press **F**.
- Select by arrows **UP** and **DOWN** : *2* as password then press **F**.
- You have access to the parameter on *oPEr* menu.
- Select by arrows **UP** and **DOWN** the required parameter.
- If the parameter is **Write/Read (W/R)** press **F** (parameter flashing) then select by arrows **UP** and **DOWN** the required value, press **F** to set the new value.
- Push simultaneously **L/R** and **F** for few seconds to **Exit** from the menu

- **Maximum output:** Its' a scaling factor of the Input command signal.

Parameter Display	Parameter Name	Contents	UM	Default Value UM	Min Value DEC	Max Value DEC	Min Value UM	Max Value UM	Par. Type
<i>outN</i>	OutN	Maximum output	%	100	0	255	0	100	R/W

Sample Values and Note

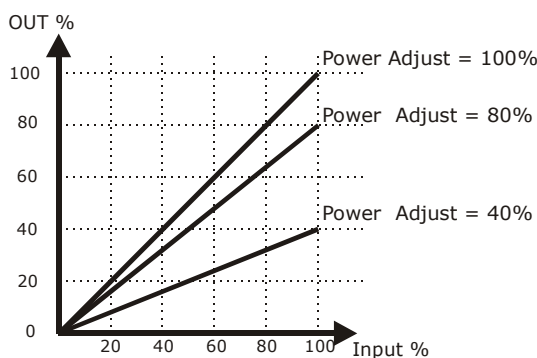

- **Power output:** This parameter shows the Average power output.

Parameter Display	Parameter Name	Contents	UM	Default Value UM	Min Value DEC	Max Value DEC	Min Value UM	Max Value UM	Par. Type
<i>P</i>	P	Power output	%	-	0	1023	0	100,0	R

- **Current Limit:**

Parameter Display	Parameter Name	Contents	UM	Default Value UM	Min Value DEC	Max Value DEC	Min Value UM	Max Value UM	Par. Type
<i>CL</i>	CL	Current Limit	%	0,0	0	1023	0	100,0	R/W

- **Current output:** This parameter shows the Average power output.

Parameter Display	Parameter Name	Contents	UM	Default Value UM	Min Value DEC	Max Value DEC	Min Value UM	Max Value UM	Par. Type
<i>A</i>	A	Current output	A	-	0	1023	0	1023	R

- **Average voltage output:** This parameter show the Average voltage output.

Parameter Display	Parameter Name	Contents	UM	Default Value UM	Min Value DEC	Max Value DEC	Min Value UM	Max Value UM	Par. Type
<i>U_{out}</i>	Vout	Average voltage	V	-	0	1023	0	1023	R/W

- **Operative Load Voltage:** This parameter is used to set in volt the operative voltage of the load.

Parameter Display	Parameter Name	Contents	UM	Default Value UM	Min Value DEC	Max Value DEC	Min Value UM	Max Value UM	Par. Type
<i>U_{oP}</i>	V_oP	Operative Load Voltage	V	229	0	1023	0	1023	R/W

- **Load nominal Current:** This parameter is used to set the Load nominal Current. This parameter is necessary to have the correct rescaling inside the unit. For this reason it's very important specify this value in the order code.

Parameter Display	Parameter Name	Contents	UM	Default Value UM	Min Value DEC	Max Value DEC	Min Value UM	Max Value UM	Par. Type
<i>A_{Lo}</i>	A_Lo	Load nominal Current	A	UnitType Max Current	0	1023	0	1023	R/W

- **Digital Input 1:**

Parameter Display	Parameter Name	Contents	UM	Default Value UM	Min Value DEC	Max Value DEC	Min Value UM	Max Value UM	Par. Type
<i>d₁</i>	Di1	Digital input 1	SW	-	0	1	0	1	R

Sample Values and Note

Di1 = *off*

Di1 = *on*

- **Digital Input 2:**

Parameter Display	Parameter Name	Contents	UM	Default Value UM	Min Value DEC	Max Value DEC	Min Value UM	Max Value UM	Par. Type
<i>d₂</i>	Di2	Digital input 1	SW	-	0	1	0	1	R

Sample Values and Note

Di2 = *off*

Di2 = *on*

- **Analog/Digital Selection:** to set the main reference parameter taken from Analogic or Digital Input

Parameter Display	Parameter Name	Contents	UM	Default Value UM	Min Value DEC	Max Value DEC	Min Value UM	Max Value UM	Par. Type
A_d	A_d	Analog/Digital Selection	SW	Digital	0	1	0	1	R/W

Sample Values and Note

A_d = *d 19* Digital

A_d = *An 1* Analog.

- **Unit Enable Selection:**

Parameter Display	Parameter Name	Contents	UM	Default Value UM	Min Value DEC	Max Value DEC	Min Value UM	Max Value UM	Par. Type
EnAb	EnAb	Unit Enable Selection	SW	Off	0	1	0	1	R/W

Sample Values and Note

EnAb = *off*

EnAb = *on*

- **Digital Set Point:**

Parameter Display	Parameter Name	Contents	UM	Default Value UM	Min Value DEC	Max Value DEC	Min Value UM	Max Value UM	Par. Type
SP	SP	Digital SetPoint	%	100.0	0	1023	0	100	R/W

Sample Values and Note

Input 4mA P015 SP = 0%

Input 12mA P015 SP = 50%

Input 20mA P015 SP = 100%

12.3 Setup Menu *SEt*

- Push simultaneously **L/R** and **F** for few seconds to **access** to the menu (*Menu* flashing).
- Select by arrows **UP** and **DOWN** : *SEt* then press **F**.
- Select by arrows **UP** and **DOWN** : *10* as password then press **F**.
- You have access to the parameter on *SEt* menu.
- Select by arrows **UP** and **DOWN** the required parameter.
- If the parameter is **Write/Read (W/R)** press **F** (parameter flashing) then select by arrows **UP** and **DOWN** the required value, press **F** to set the new value.
- Push simultaneously **L/R** and **F** for few seconds to **Exit** from the menu

▪ **Set Firing type:**

Parameter Display	Parameter Name	Contents	UM	Default Value UM	Min Value DEC	Max Value DEC	Min Value UM	Max Value UM	Par. Type
<i>Fir</i>	Fir	Firing mode Selection	SW	3*	0	1024	0	1024	R/W

*Default Value if not specified in the Order Code

Sample Values and Note

4= Phase Angle *PA*
 20 = Soft Start + Phase Angle *PASt*
 35=Delay Triggering + Burst Firing *bFdt*

▪ **Ramp Up Settings:**

This parameter have two functions: if the firing mode is Phase Angle Time to reach the full angle of firing. The Unit starts in phase angle mode with a ramp starting from zero up to full voltage in a presetted and Adjustable time. The time is setted by this parameter

Parameter Display	Parameter Name	Contents	UM	Default Value UM	Min Value DEC	Max Value DEC	Min Value UM	Max Value UM	Par. Type
<i>rP_u</i>	rP_u	Sofstart - Ramp Up	%	100	0	255	0	255	R/W

Sample Values and Note

Only with Fir = Phase Angle *PA*

▪ **Set HB sensitivity:**

This parameter defines the threshold of resistance that activates the HB alarm
 This value is in percentage respect the nominal resistance load value

Parameter Display	Parameter Name	Contents	UM	Default Value UM	Min Value DEC	Max Value DEC	Min Value UM	Max Value UM	Par. Type
<i>Hb_S</i>	Hb_S	HB sensitivity	%	100	0	100	0	100	R/W

▪ **Set HB Delay:** This parameter set a delay to have HB alarm active

Parameter Display	Parameter Name	Contents	UM	Default Value UM	Min Value DEC	Max Value DEC	Min Value UM	Max Value UM	Par. Type
<i>Hb_d</i>	Hb_S	HB delay	sec	20	0	255	0	255	R/W

- **Set FeedBack type:** This parameter selects the Feed-back type.

Parameter Display	Parameter Name	Contents	UM	Default Value UM	Min Value DEC	Max Value DEC	Min Value UM	Max Value UM	Par. Type
FEEd	FEEd	Feed back selection	SW	1*	0	1024	0	1024	R/W

*Default Value if not specified in the Order Code

Sample Values and Note

0 = V2 U²
 1 = NO Feed Back nooñE
 32 = Voltage V U
 64 = Current I I
 128 = Power V X I P

- **Ramp Cycle Burst Firing:**

It defines the number of voltage cycles in ON condition at 50% of power demand

Parameter Display	Parameter Name	Contents	UM	Default Value UM	Min Value DEC	Max Value DEC	Min Value UM	Max Value UM	Par. Type
bF_n	bF_n	Burst Firing Cycles	Cycle	4*	1	255	1	255	R/W

*Default Value if not specified in the Order Code

Sample Values and Note

Only with Fir = Delay Triggering + Burst Firing **bFdt**

- **Set Delay Triggering:** This parameter set firing delay in °

Parameter Display	Parameter Name	Contents	UM	Default Value UM	Min Value DEC	Max Value DEC	Min Value UM	Max Value UM	Par. Type
dt	dt	Delay Triggering	°	1	1	255	1	255	R/W

Sample Values and Note

Only with Fir = Delay Triggering + Burst Firing **bFdt**

- **Set Proportional Band:** This parameter is the gain of the feed-back loop.

Parameter Display	Parameter Name	Contents	UM	Default Value UM	Min Value DEC	Max Value DEC	Min Value UM	Max Value UM	Par. Type
Pb	Pb	Proportional Band	%	8	1	255	1	255	R/W

- **Set Integral Time:** This parameter is the integral time of the feed-back loop.

Parameter Display	Parameter Name	Contents	UM	Default Value UM	Min Value DEC	Max Value DEC	Min Value UM	Max Value UM	Par. Type
t_i	ti	Set Integral time	%	20	1	255	1	255	R/W

- **Start Up Displayed Parameter:** This parameter select the default output value displayed at the start up of the unit.

Parameter Display	Parameter Name	Contents	UM	Default Value UM	Min Value DEC	Max Value DEC	Min Value UM	Max Value UM	Par. Type
StPr	ti	Start Up Parameter	SW	U	0	1024	0	1024	R/W

Sample Values and Note

81 = Voltage output *U*
 82 = Current output *I*
 128 = Power V X I *P*

12.4 Hardware Menu *HARd*

- Push simultaneously **L/R** and **F** for few seconds to **access** to the menu (*Menu* flashing).
- Select by arrows **UP** and **DOWN** : *HARd* then press **F**.
- Select by arrows **UP** and **DOWN** : *5* as password then press **F**.
- You have access to the parameter on *HARd* menu.
- Select by arrows **UP** and **DOWN** the required parameter.
- If the parameter is **Write/Read (W/R)** press **F** (parameter flashing) then select by arrows **UP** and **DOWN** the required value, press **F** to set the new value.
- Push simultaneously **L/R** and **F** for few seconds to **Exit** from the menu

▪ Set Analog input Value:

Parameter Display	Parameter Name	Contents	UM	Default Value UM	Min Value DEC	Max Value DEC	Min Value UM	Max Value UM	Par. Type
<i>A_In</i>	A_1n	Input type	V	3*	0	255	0	255	R/W

Sample Values and Note

1 = 0-10 Vdc	<i>0_10</i>
2 = 4-20 mA	<i>4_20</i>
3 = 0-20 mA	<i>0_20</i>

▪ Set Minimum input1 value:

Parameter Display	Parameter Name	Contents	UM	Default Value UM	Min Value DEC	Max Value DEC	Min Value UM	Max Value UM	Par. Type
<i>L A1</i>	L A1	Save value Minimum input 1	Sw	0	0	1	0	1	R/W

Sample Values and Note

Default Value	<i>dEF</i>
Save Value	<i>SAuE</i>

▪ Set Maximum input1 value:

Parameter Display	Parameter Name	Contents	UM	Default Value UM	Min Value DEC	Max Value DEC	Min Value UM	Max Value UM	Par. Type
<i>H A1</i>	HiA1	Save value Maximum input 1	Sw	0	0	1	0	1	R/W

Sample Values and Note

Default Value	<i>dEF</i>
Save Value	<i>SAuE</i>

- **Digital input 1 configuration :** This parameter selects the function of digital input.

Parameter Display	Parameter Name	Contents	UM	Default Value UM	Min Value DEC	Max Value DEC	Min Value UM	Max Value UM	Par. Type
[di1]	CDi1	Digital input 1 configuration	SW	0	0	3	0	3	R/W

Sample Values and Note

- 0 = Enable *EnAb*
- 1 = Change To V FeedBack *Fbtr*
- 2 = L/R Enable *LrC*
- 3 = Change Firing PA/xx *F irC*

- **Digital input 2 configuration :** This parameter selects the function of digital input.

Parameter Display	Parameter Name	Contents	UM	Default Value UM	Min Value DEC	Max Value DEC	Min Value UM	Max Value UM	Par. Type
[di2]	CDi2	Digital input 2 configuration	SW	1	0	3	0	3	R/W

Sample Values and Note

- 0 = Enable *EnAb*
- 1 = Change To V FeedBack *Fbtr*
- 2 = L/R Enable *LrC*
- 3 = Change Firing PA/xx *F irC*

- **Digital Output 1 configuration :**

Parameter Display	Parameter Name	Contents	UM	Default Value UM	Min Value DEC	Max Value DEC	Min Value UM	Max Value UM	Par. Type
[do1]	CDo1	DigitalOut. 1 configuration	SW	0	0	3	0	3	R/W

Sample Values and Note

- 0 = Enable HB SCR *ALEn*
- 1 = Enable SCR Current Limit *SC IL*
- 2 = Enable HB Current Limit *Hb IL*
- 3 = Enable Current Limit Alarm *ILEn*
- 4 = Enable HB SCR *HbSC*
- 5 = Enable SC Alarm *SCEn*
- 6 = Enable HB Alarm *HbEn*
- 7 = Disable HB SCR I Limit *NonE*

- **Serial port Baud Rate :** This parameter selects the Baud rate on the serial port.

Parameter Display	Parameter Name	Contents	UM	Default Value UM	Min Value DEC	Max Value DEC	Min Value UM	Max Value UM	Par. Type
bAud	bAud	Baud Rate	SW	2	0	3	0	3	R/W

Sample Values and Note

0 = 4800 baud	4800
1 = 9600 baud	9600
2 = 19200 baud	1920
3 = 38400 baud	3840

- **Serial port Address :**

This parameter selects the Address on the serial port for the thyristor unit.

Parameter Display	Parameter Name	Contents	UM	Default Value UM	Min Value DEC	Max Value DEC	Min Value UM	Max Value UM	Par. Type
Addr	Addr	Address	Add.	1	1	255	1	255	R/W

- **Current Limit Mode:**

Parameter Display	Parameter Name	Contents	UM	Default Value UM	Min Value DEC	Max Value DEC	Min Value UM	Max Value UM	Par. Type
CL_i	CL_i	Current Limit mode	Sw	0	0	1	0	1	R/W

Sample Values and Note

Only with Fir = Phase Angle **PA**

0 = Current Limit Analog Setting = **An_i**

1 = Current Limit Setting in Digital Via Panel/ RS485 = **d_i9**

12.5 Control Panel Led

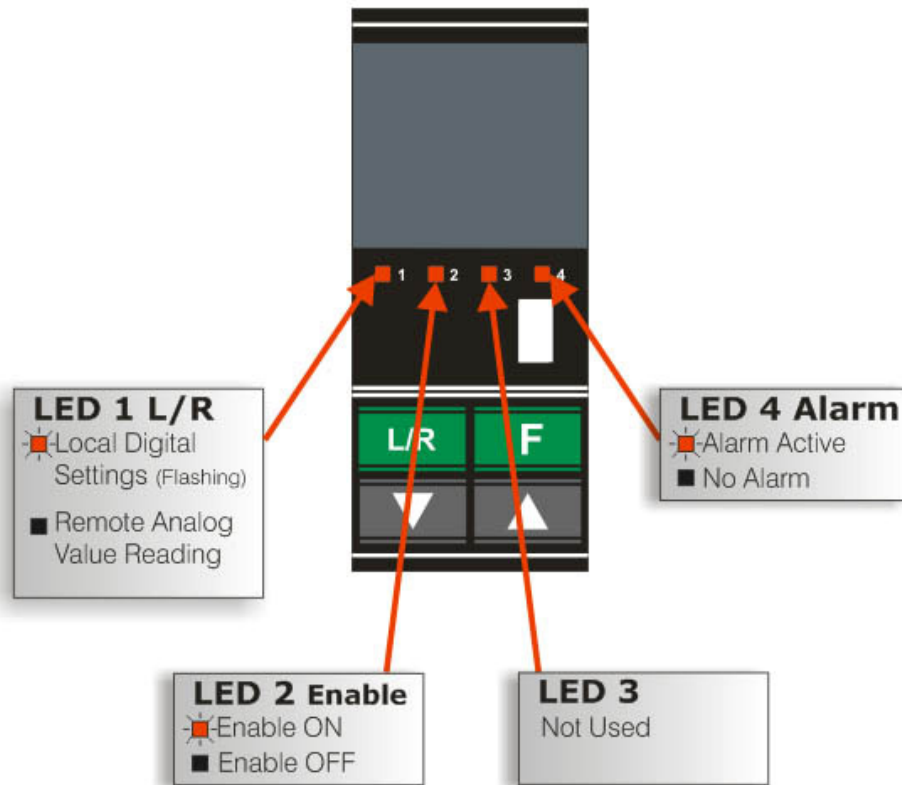

12.6 Displayed Alarms

Alarm on Display	Description
SHrt	Short Circuit on SCR!
ALHb	Heater Break Alarm!
Lim1	Current Limit!

13 Input output signal

13.1 Digital Input

The REVO CL thyristor unit has 2 digital inputs opto-isolated to 24Vdc 5 mA.
You can activate the inputs with the internal supply or with an external source for example the PLC.

13.1.1 Enable (Terminal 16 on S9 , 5 on S12)

This is the start command (Enable) of the REVO CL.
If you Remove the Start command the REVO CL thyristor unit will be stopped and the output will return at zero.

13.1.2 Configurable Input (Terminal 15 on S9 , 6 on S12)

This digital input is configured by the parameter Cd_i and could perform different functions:

- Enable:
This function forces the output at zero.
- Feed-Back Selection:
With this function, when you active the input, the feed-back setted in the parameter $FEED$ change in Voltage Feed-Back (V).
- Analog/Digital Setpoint(Local/Remote):
With this function, when you active the input, the setpoint reference change from Analog input to Digital value in bumpless mode, setted in the parameter SP . The parameter SP is not stored in memory.
- Change Firing type:
With this function, when you active the input, the Firing type setted in the parameter Fir change in Phase Angle PA.

13.1.3 Digital Output (terminal 18-19-20 on S9 , 1-2-3 on S12)

The REVO CL thyristor unit has 1 relay output on terminal 18-19-20 of terminal block M1(Max 500mA, 125Vac). The functionality of this output can be setted with the parameter Co_i
This digital output can be configured in order to activate itself after that one of these alarms occurs:

- HB and SC alarm are active.
- Only HB alarm is active.
- Only SC alarm is active.

13.2 Analog Input

Primary Input (Terminals 9 and 10 on S9 , 11-12 on S12)

The REVO CL thyristor unit has 1 analog inputs (0÷10V, 0÷20mA, 4÷20mA ecc):
The primary input for the analog setpoint.

The primary input is already configured in line with customer requirements that are defined in the Order Code. The Order Code is written on the identification label.
However, if you wish to change the primary input (ex. from 0÷10V to 0÷20mA, 4÷20mA).
see par. Analog Inputs 18 for details.

14 Heater Break alarm and SCR short circuit (HB Option)



Caution: to work properly the load must be powered at least about 160msec.

The Heater Break circuit read the load resistance with an Internal voltage transducer and Internal current transformer (C.T.), to calculate the resistance (V/I).

Minimum current is 10% of the current transformer size.

If load current is below this value the Heater Break Alarm doesn't work properly.

14.1 Heater break Calibration procedure

An automatic function sets the Heater Break Alarm ,when write in the parameter **A_{Lo}** the load current and in the parameter **U_{oP}** the load voltage.

If the load resistance increases due to a partial or total load failure ,the HB alarm become ON and alarm relay change status.

You can Adjust the sensibility of HB alarm by using the parameter **Hb_S** This parameter is set between 1 and 255% of the nominal resistance.

This parameter is the maximum increment of the resistance Load to establish the HB Alarm.

There is also **Hb_d** parameter to set a delay to have HB alarm active.

14.2 HB alarm contact (digital output)

The Revo unit with HB option, is supplied with Heater Break alarm contact normally opened (NO):

- In normal conditions (without alarm) and with auxiliary power supply, the contact to the terminals has opened (relay coil energized).
- In alarm condition or without auxiliary power supply the contact to the terminals is closed (relay coil not energized).

This alarm can be configured in order to activate itself after that one of these alarms occurs:

- HB and SC alarm are active.
- Only HB alarm is active.
- Only SC alarm is active.
- Disable the relay output.

15 Firing type

Choose an correct firing type allows to optimize the thyristor unit for the installed load.

The firing type has already configured in line with customer requirements that are defined in the Order Code. The Order Code is written on the identification label.

However, if you wish to change the firing type you can use the software configurator or the ControlPanel



Caution: this procedure must be performed only by qualified persons.

15.1 Phase Angle (PA PA)

The Phase Angle firing allow the control of the power on the load, for this firing the thyristor can be in conduction only for a part of the voltage cycle.

This part of the voltage cycle is adjustable in function of the input signal from 0 at 100%.

The PA firing is normally used for control the inductive loads, and is also possible control a primary of transformer coupled with the cold resistances like: Superkanthal, Molybdenum, Platinum, Tungsten or Quartz Lamp. The only disadvantage with phase angle is the possible generation of interferences that however can be reduced with opportune filters.

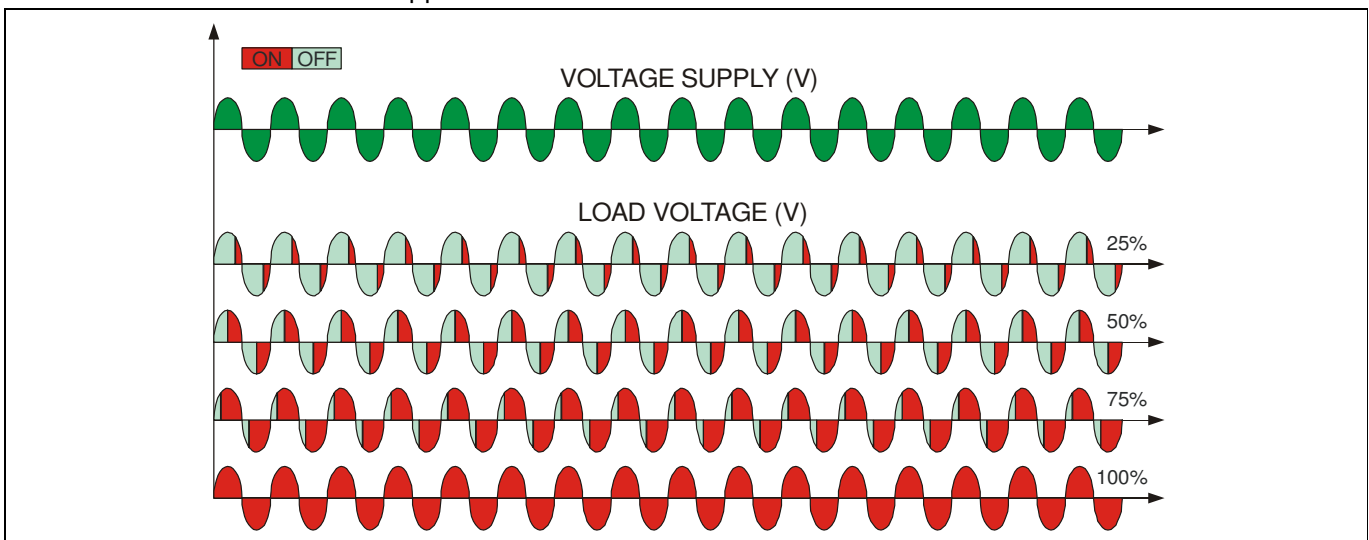

15.2 Soft Start with Phase Angle (S+PA PASt)

This is an additional function to the Phase Angle. The firing angle of the thyristor increase or decrease up to the final setpoint value.

The Soft start ramp is an important feature to reduce the inrush current with transformers during the during the cycle of magnetization or with cold resistance that are near to the short circuit when they are supplied.

Setpoint Ramp Up / Setpoint Ramp Down : rP_{u}

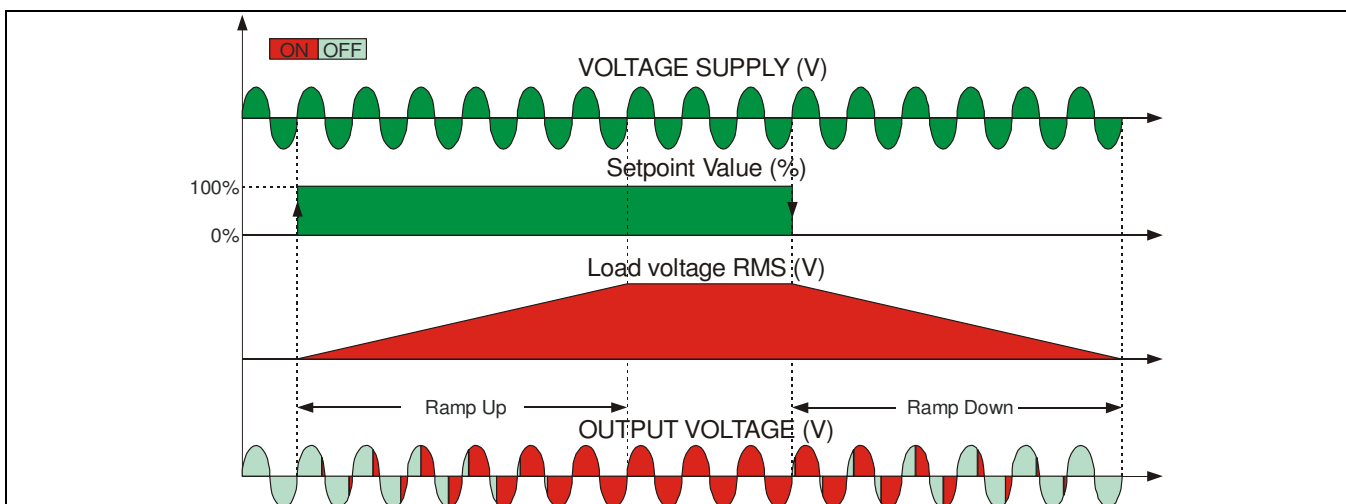

15.3 Delay Triggering with Burst Firing (DT+BF $bFdt$)

The Delay Triggering DT firing is used to control a primary of transformer coupled with the normal resistances on the secondary (N.B. don't connect cold resistances on the secondary like: Superkanthal, Molybdenum, Platinum, Tungsten, Quartz Lamp).

For an inductive load (ex transformer), switching the thyristors at zero crossing can generate transient over currents that can blow the fuses, to avoid this problem you must use the Delay Triggering. This firing delay the first half cycle of Burst for an angle from 0 to 100° relative to the zero, besides all the first burst start with soft start ramp to reduce the inrush current during the cycle of magnetization.

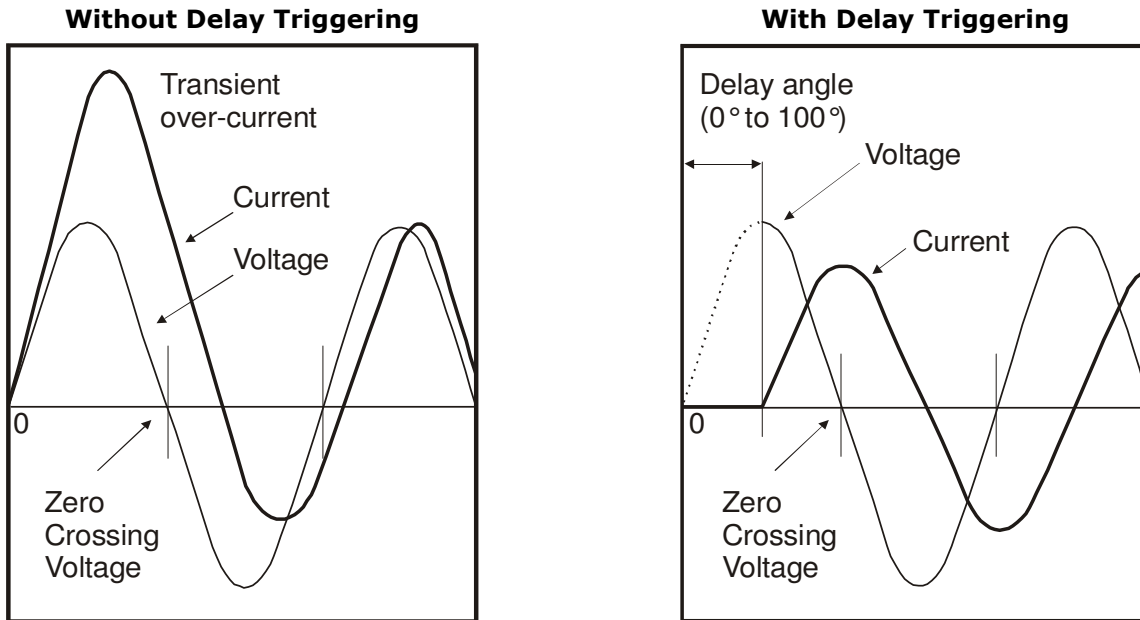

For understand the Delay Triggering firing, we have represented the waves generate by vectors that rotates in counterclockwise:

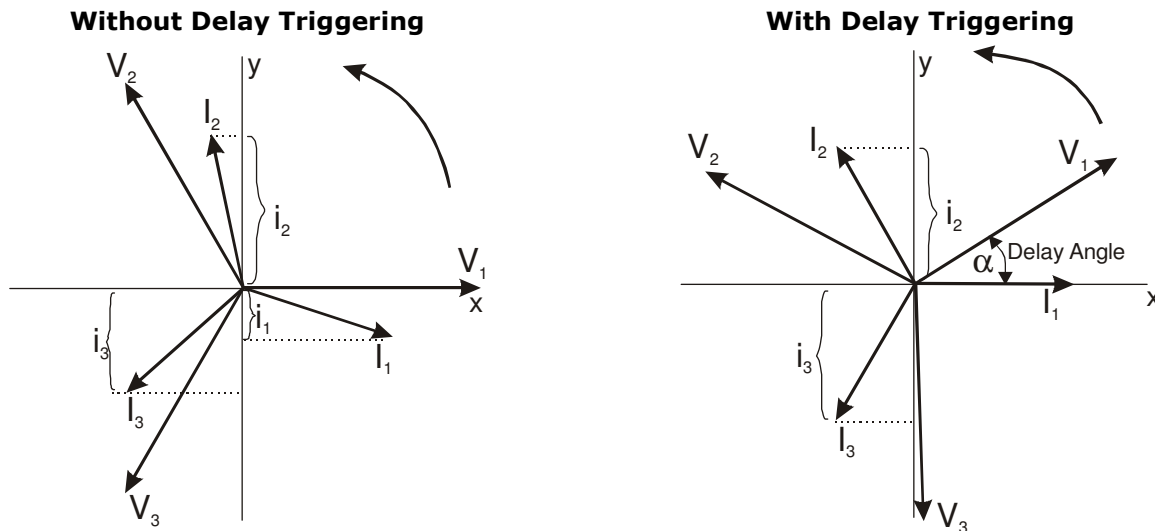

Without delay at zero crossing when V_1 is to zero (projected on the X axis) the unit switch On. In this case the instantaneous value of the currents are i_1 , i_2 and i_3 and this condition, for the curve of magnetization, could generate transient over currents that can blow the fuses.

With Delay Triggering the firing of the thyristor are triggered with a delay until the instantaneous value of the current $i_1=0$, i_2 positive and i_3 negative like represented.

In this case the risk of transient over currents is reduced and the fuses don't blow.

The angle alpha is the delay to have $i_1=0$ and this angle depends on the power factor.

The delay angle suggest for most applications is 80°

The Burst Firing BF is similar to the Single Cycle, but consecutive cycles ON are selectable between 2 and 255, with input signal equal at 50%.

Burst Firing is a method zero crossing that it reduces the electromagnetic interferences because the thyristor switches at zero voltage crossing.

The example show the Burst Firing with Burst cycles: $bF_{-n} = 4$

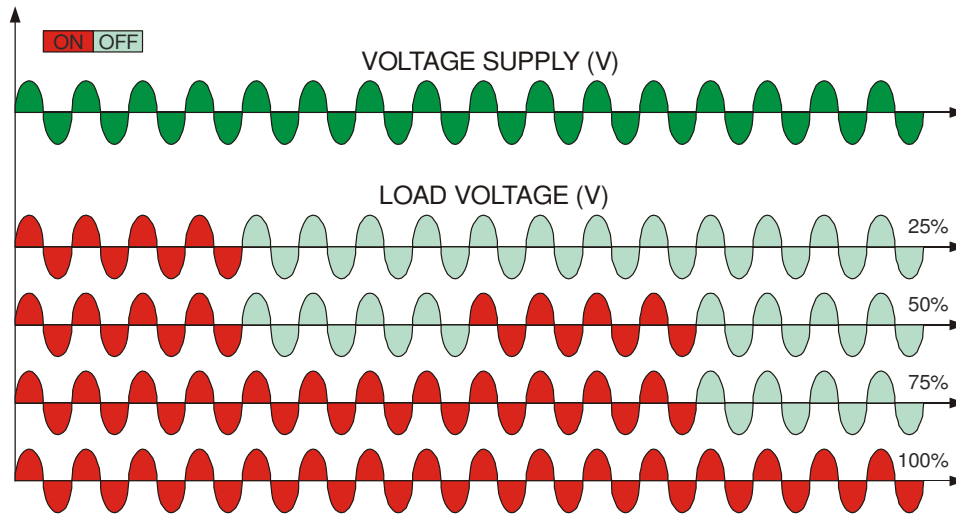

16 Current Limit

The Current Limit is available on REVO CL with Phase Angle firing mode only. It control the firing angle of the thyristor to maintain the three RMS current under the set value. When the current exceeds this value, the voltage is decreased up to reach the current limit set.

I Load \leq I Limit Set

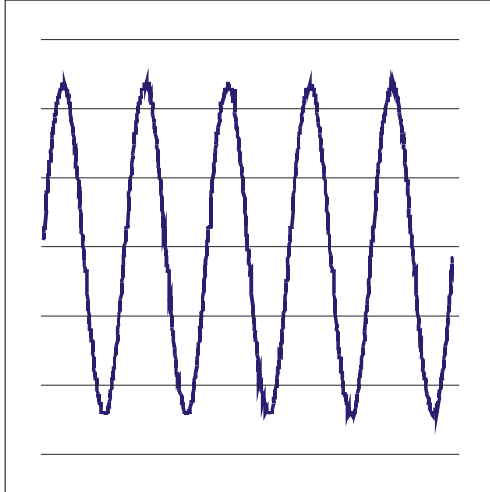

I Load $>$ I Limit Set

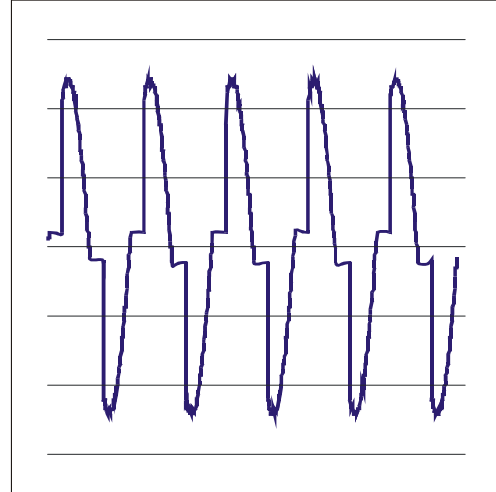

16.1.1 Current Limit Setting

The setting of the current limit value can be done in two ways :Digital or Analogic.

- **Digital:** Set the parameter $CL_{i} = d_{i9}$ from the hardware menù
Set the current limit value by the parameter CL . from 0 a 100% Of the Current. (Operator menu)
- **Analogic:** Set the parameter $CL_{i} = An_{i}$ from the hardware menù
The value of the Current Limit is setted with analog input 2 Teeminals 6 (-) e 8 (+).

This analog input is 0 – 10V and input impedance 10Kohm.

The settings functions by the analogic input is called also external current limit profile because allows to change the profile of the Current Limit during the process.



Caution: this procedure must be performed only by qualified persons.

16.1.2 Current Limit tuning procedure

- Give the power supply and set the current limit to zero:
 - In analog mode, set the analog input 2 to zero
 - In digital mode, set the parameter $CL = 0$
- Start the thyristor unit .
- Set the primary input or the setpoint value at 100% .
- Increase the current limit
 - In analog mode increase the value of the analaog input
 - In digital mode increase the parameter CL until to reach the desired value of rms current .
- Stop the thyristor unit.

The Current Limit Procedure is done.

17 Feed-back type

The Feed-back type has already configured in line with customer requirements that are defined in the Order Code. The Order Code is written on the identification label. However, if you wish to change the Feed-back type you can use the software configurator or the Control Panel.



Caution: *this procedure must be performed only by qualified persons.*

The Feed-back type is defined by the parameter *FEEd* .

If the configurable digital input has set like Feed-Back Selection ,it's possible to change the select Feed-Back with the Voltage Feed-Back (V) simply activating the input.

The feed-back defines the Control Mode. It's possible to have:

- **V** = Voltage feed-back.
The input signal is proportional to the output voltage. This means that input signal becomes a voltage demand. This control mode compensates the voltage fluctuation of the incoming line supply.
- **W** = Power feed-back.
The input signal is proportional to the power output. This means that input signal becomes a power demand. The power remains constant also if voltage and load impedance change. This control mode is used with silicon carbide elements that change its resistive value with temperature and with age. In addition it compensates the voltage fluctuation of the incoming line supply.
- **I** = Current feed-back.
The input signal is proportional to the current output. This means that input signal becomes a current demand. This control mode maintain the current also if the load impedance changes.
- **V2** = Square Voltage feed-back.
The input signal is proportional to the output square voltage. This means that input signal becomes a power demand. The power remains constant if the load impedance doesn't change.
- **NO**=No Feedback Open Loop. The input is proportional to the firing angle (α).

17.1 Supply the Electronic Board

The REVO CL thyristor unit, to work, requires a voltage supply for the electronic boards. The Max consumption is 10VA.

The voltage supply for the electronic boards is configured in line with customer requirements that are defined in the Order Code. The Order Code is written on the identification label.



Warning: Before connecting or disconnecting the unit check that power and control cables are isolated from voltage sources.

S9 Terminal	S12 Terminal	Description
1	18	Voltage Supply for Electronic Boards
2	19	Not Used
3	20	Voltage Supply for Electronic Boards

To change auxiliary supply voltage sold the correct link-jumper on board
The type of mounted transformer depends of the chosen Voltage in the order code.

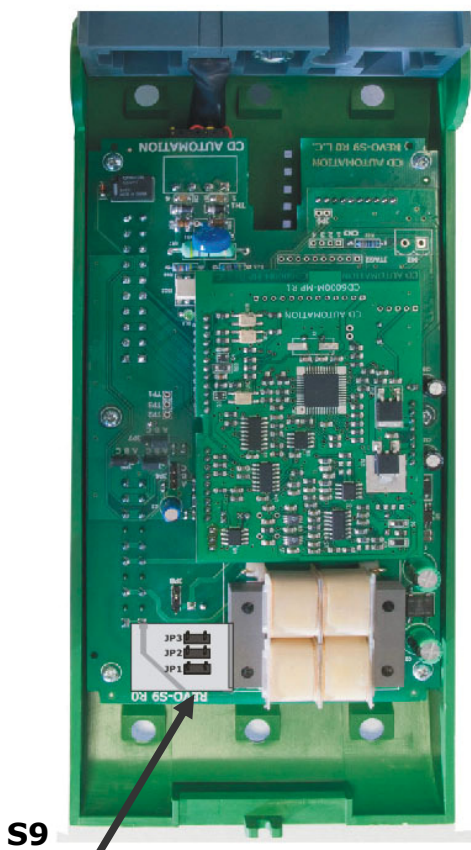

S9

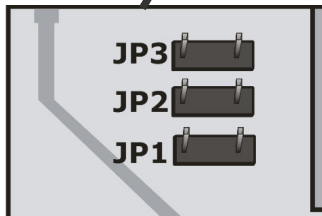

S12

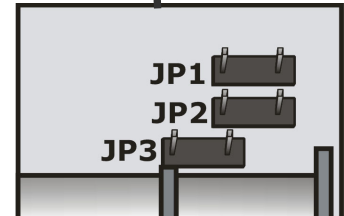

Transformer Type	Link-Jumper JP1+JP2	Link-Jumper JP3
TR-605 120V	90:130V	170:265V
TR-605 230V	170:265V	300:530V
TR-605 300V	230:345V	510:690V

If the Auxiliary Voltage (written on the identification label) is different from Supply Voltage (to the load), use an external transformer with primary equal to load voltage and secondary equal to the Auxiliary Voltage

18 Analog Inputs

The REVO CL thyristor unit has 2 configurable analog inputs (0÷10V, 4÷20mA, ecc):

The primary input for the analog setpoint, the secondary input for the Current Profiler or Ext. Feed-Back.

Primary Input

The primary input is already configured in line with customer requirements that are defined in the Order Code. The Order Code is written on the identification label.

However, if you wish to change the primary input (ex. from 0÷10V to 4÷20mA) proceed as follows:

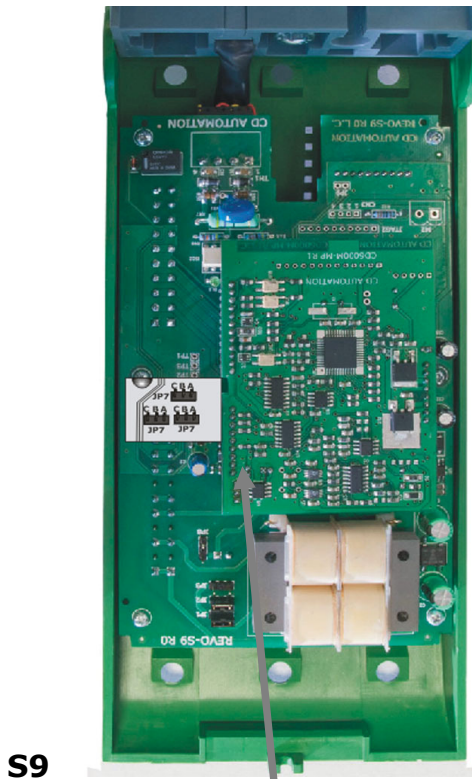

S9

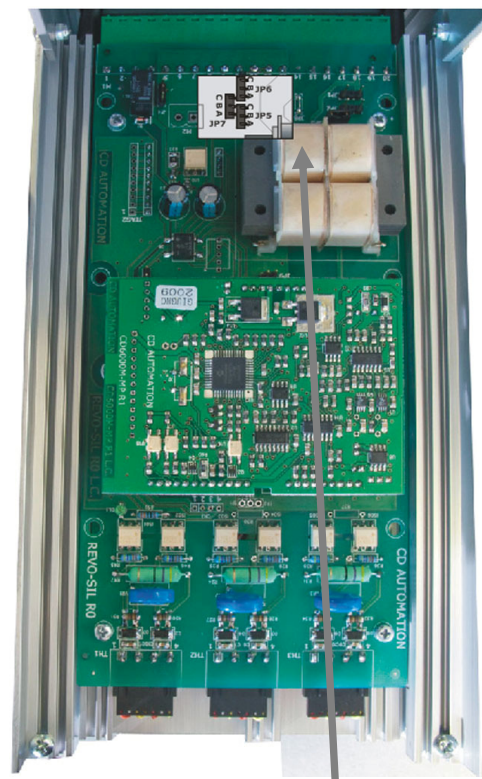

S12

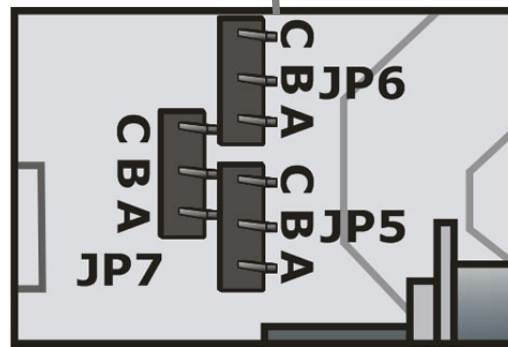
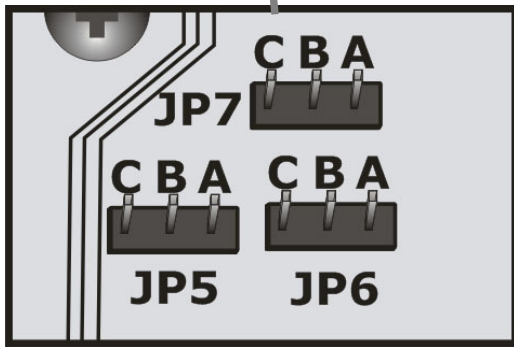

	0 ÷ 10	4 ÷ 20	SSR						
<table border="1"> <tr><td>A</td><td>■</td></tr> <tr><td>B</td><td>■</td></tr> <tr><td>C</td><td>■</td></tr> </table> JP5	A	■	B	■	C	■	B-C	B-C	A-B
A	■								
B	■								
C	■								
<table border="1"> <tr><td>A</td><td>■</td></tr> <tr><td>B</td><td>■</td></tr> <tr><td>C</td><td>■</td></tr> </table> JP6	A	■	B	■	C	■	B-C	B-C	A-B
A	■								
B	■								
C	■								
<table border="1"> <tr><td>A</td><td>■</td></tr> <tr><td>B</td><td>■</td></tr> <tr><td>C</td><td>■</td></tr> </table> JP7	A	■	B	■	C	■	B-C	A-B	-
A	■								
B	■								
C	■								

Type	Input features	
0÷10V (default)	Impedance	15KΩ
POT	Impedance	10KΩ min
4÷20mA	Impedance	100Ω

Primary Input calibration procedure

When you change the hardware setting is necessary make the Input calibration procedure.

To make the Input calibration procedure follow these steps:

- Give the power supply.
- With Control Panel go in the Hardware menu ($PASS = 5$)
- Set the input signal to the min value (ex. 0V for 0÷10V or 4mA for 4÷20mA)
- Set the parameter $L \ iA \ i = 1$
- Press ENTER key
- Set the input signal to the max value (ex.10V for 0÷10V or 20mA for 4÷20mA)
- Set the parameter $H \ iA \ i = 1$
- Press ENTER key

The Input calibration procedure is done.

19 RS485 Serial Port

The serial communication port RS485 is available on the Command Terminals.

On this port may be done a network up to 127 REVO CL.

S9 Terminal	S12 Terminal	Description
14	7	RS485 A
13	8	RS485 B

20 PG Connector

The PG Connector is used to configure the thyristor unit with the configuration software and with the programming cable.
The programming cable is not included.

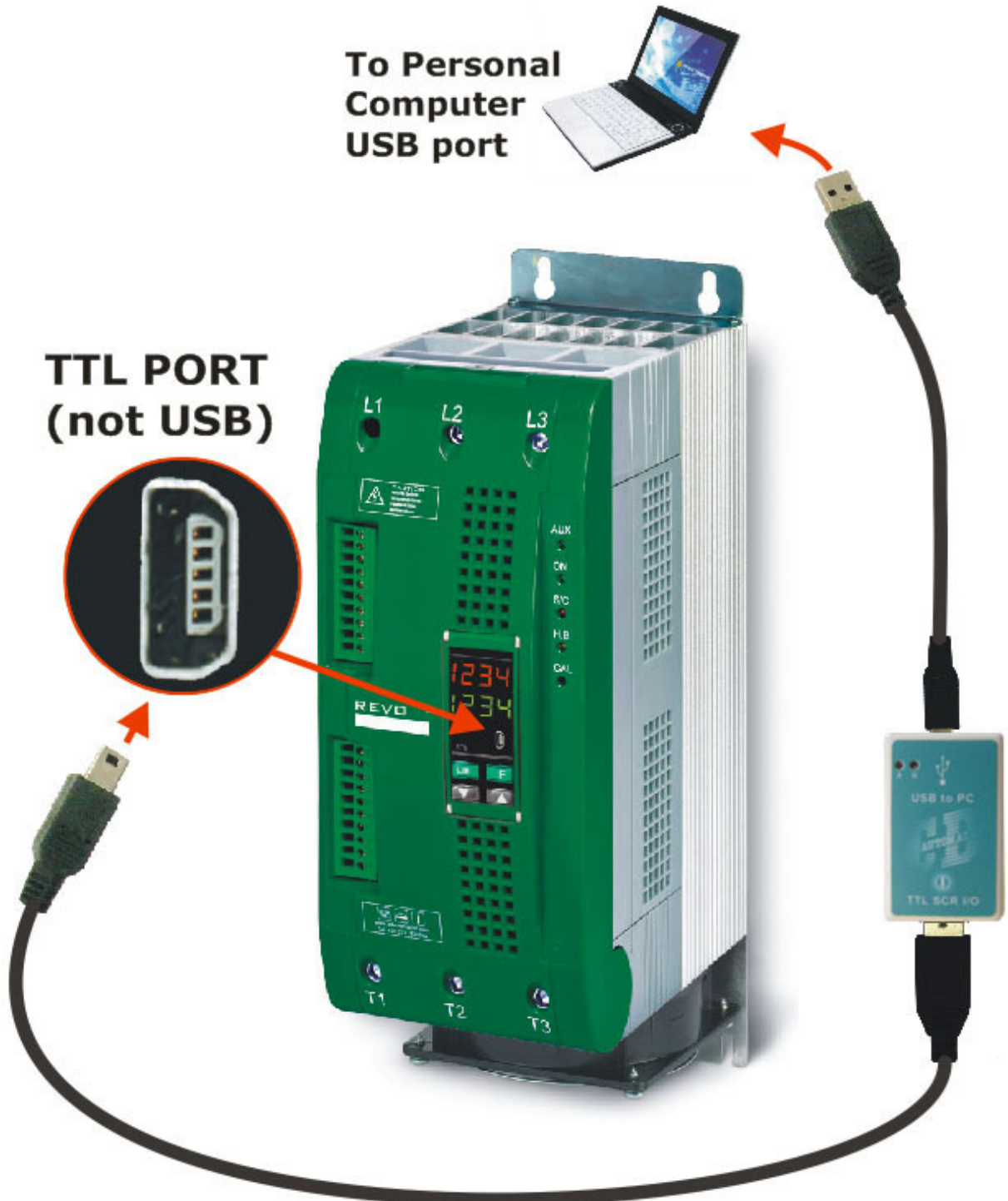

21 Internal Fuse

The thyristor unit have internal fuse extrarapid at low I^2t for the thyristor protection of against the short-circuits.

The Fuses must have I^2t 20% less than thyristor's I^2t . The warranty of thyristor is null if no proper fuses are used.

Type	Fuse Code Spare Part	Current (ARMS)	I^2T (A ² sec.)	Vac
280A (S9)	FUURB315	315	82000	660
400A (S12)	FU550FMM	550	215000	660
500A (S12)	FU700FMM	700	420000	660
600A (S12)	2xFU450FMM	900	420000	660
700A (S12)	2xFU450FMM	900	420000	660



Caution: High speed fuses are used only for the thyristor protection and can not be used to protect the installation.



Caution: The warranty of thyristor is null if no proper fuses are used. See tab.



Warning: When it is supply, the Thyristor unit is subject to dangerous voltage, don't open the Fuse-holder module and don't touch the electric equipments.

22 Maintenance

In order to have a corrected cooling, the user must clean the heat-sink and the protective grill of the fans. The frequency of this servicing depends on environmental pollution.

Also check periodically if the screw for the power cables and safety earth are tightened correctly (See Connection Diagram)

22.1 Trouble Shooting

Small problems sometimes can be solved locally with the help of the below tab of trouble shooting. If you don't succeed, contact us or your nearest distributor.

Symptom	Indication on front unit	Possible reasons of the symptom	Actions
Load current doesn't flow	Green LED (ON) light OFF	<ul style="list-style-type: none"> No Auxiliary Voltage No input signal Reversed polarities of input signal 	<ul style="list-style-type: none"> Give auxiliary voltage supply (See Connection Diagram) Provide to give input signal Reverse the input signal polarity
	Green LED (ON) light ON	<ul style="list-style-type: none"> Fuse failure Load connection interruption Load failure: The yellow led (HB) is light on (with HB option) Thyristor fault: The red led (SC) is light on (with HB option) 	<ul style="list-style-type: none"> Change the fuse Check the wiring Check the load Change the thyristor module
Thyristor unit doesn't work properly		<ul style="list-style-type: none"> Auxiliary voltage supply out of limits Wrong input signal selection. Wrong input signal calibration (out of range) 	<ul style="list-style-type: none"> Verify the auxiliary voltage supply Control input signal setting. Check input setting

22.2 Warranty condition

CD Automation gives a 12 months warranty to its products. The warranty is limited to repairing and parts substitution in our factory and does exclude products not properly used and fuses. Warranty does not include products with serial numbers deleted. The faulty product should be shipped to CD Automation at customer's cost and our Service will evaluate if product is under warranty terms. Substituted parts remain of CD Automation property.



