

<b>RTD TRANSMITTER</b> (PC programmable)	MODEL <b>27RS</b>
---	-------------------

**BEFORE USE ....**

Thank you for choosing M-System. Before use, please check contents of the package you received as outlined below. If you have any problems or questions with the product, please contact M-System's Sales Office or representatives.

■ **PACKAGE INCLUDES:**

Signal conditioner .....(1)

■ **MODEL NO.**

Confirm Model No. marking on the product to be exactly what you ordered.

■ **INSTRUCTION MANUAL**

This manual describes necessary points of caution when you use this product, including installation, connection and basic maintenance procedures.

When using this product in potentially explosive atmosphere or hazardous (classified) location, you have to follow the safety procedure to install it. Please refer to "SAFE INSTALLATION MANUAL" for each type of certification.

**POINTS OF CAUTION**

■ **CONFORMITY WITH EU DIRECTIVES**

- The actual installation environments such as connected devices and connected wires may affect the protection level of this unit when it is integrated in a panel system. The user may have to review the CE requirements in regard to the whole system and employ additional protective measures to ensure CE conformity.

■ **GENERAL PRECAUTIONS**

- Before you remove the module, turn off the power supply and input signal for safety.

■ **ENVIRONMENT**

- When heavy dust or metal particles are present in the air, install the module inside proper housing with sufficient ventilation.
- Do not install the module where it is subjected to continuous vibration. Do not subject the module to physical impact.
- Environmental temperature must be within -40 to +85°C (-40 to +185°F) with relative humidity within 0 to 95% RH in order to ensure adequate life span and operation.

■ **WIRING**

- Do not install cables close to noise sources (relay drive cable, high frequency line, etc.).
- Do not bind these cables together with those in which noises are present. Do not install them in the same duct.

■ **AND ....**

- The module is designed to function as soon as power is supplied, however, a warm up for 10 minutes is required for satisfying complete performance described in the data sheet.

**COMPONENT IDENTIFICATION**

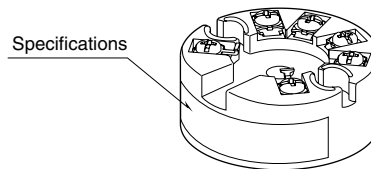

**INSTALLATION unit : mm (inch)**

This module is suitable for mounting inside a DIN type B head.

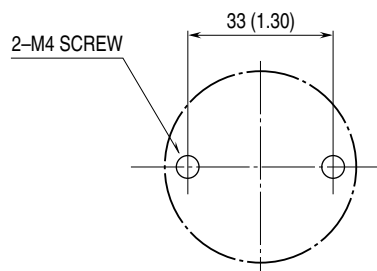

The screws are to be provided by the customer.

**EXTERNAL DIMENSIONS unit : mm (inch)**

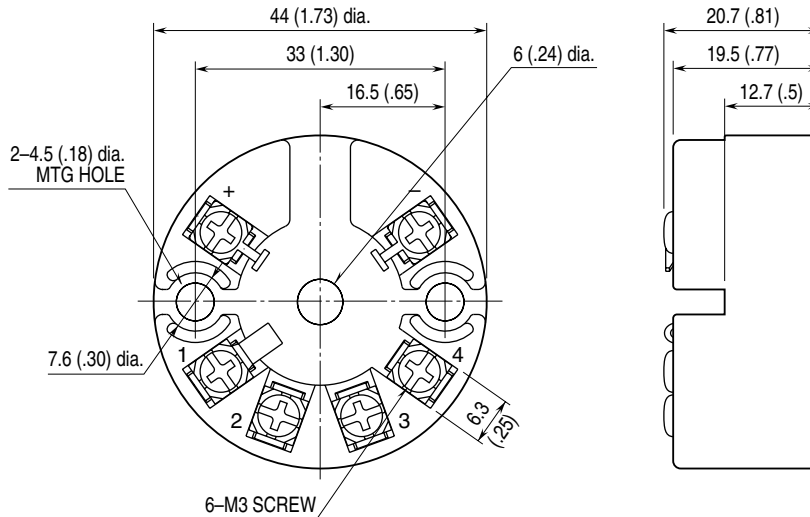

**TERMINAL CONNECTIONS**

Connect the module as in the diagram below.

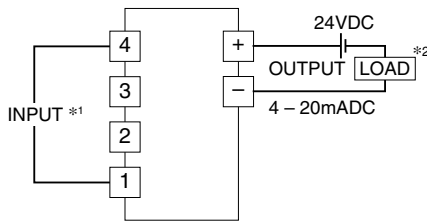

\*1. Input Connection Examples

■ RTD & RESISTANCE

• Two-wire

• Three-wire

• Four-wire

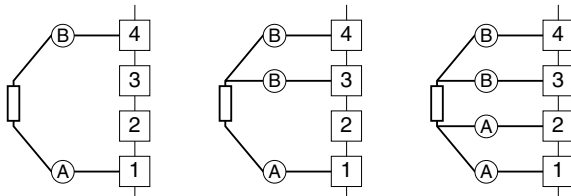

\*2. Limited to 250 – 500Ω when using the communication to configure the module.

**CHECKING**

- 1) Terminal wiring: Check that all cables are correctly connected according to the connection diagram.
- 2) Input: Check the input signal.  
If RTD wires are broken, the output goes over 100% (below 0% with downscale protection) due to burnout protection function. Check leadwires in such a case.
- 3) Output: Check that the load is within the permissible limit including wiring resistance.

$$\text{Load Resistance } (\Omega) = \frac{\text{Supply Voltage (V)} - 9 \text{ (V)}}{0.023 \text{ (A)}}$$

(including leadwire resistance)

**ADJUSTMENT PROCEDURE**

To calibrate the signal to match with a receiving instrument or to change the factory-set configurations, use the PC Configurator software installed on a Windows PC via the Bell202 Modem (models COP-HU). The PC Configurator software is downloadable at M-System's web site: <http://www.m-system.co.jp>

**WIRING INSTRUCTIONS**

■ TERMINAL SCREW

Torque: 0.5 N·m

## FUNCTION MONITOR LED (option /M)

### FUNCTION MONITOR LED

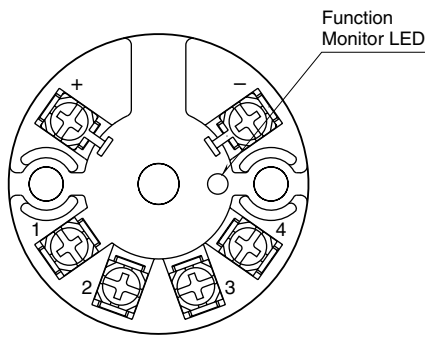

■ **INPUT MONITOR:** The input 0 – 100% is converted into a combination of 1-second (1 unit) and 0.25-second (0.2 unit) cycled pulses. 1 unit corresponds to 25%, while 0.2 unit corresponds to 5%. 0% equals to 1 unit, while 100% corresponds to 5 units. The input % is represented in the total number of 1-unit pulses and 0.2-unit pulses, repeated in the sequence of '1-unit pulses → 0.2-unit pulses → OFF for 1 second or more.'

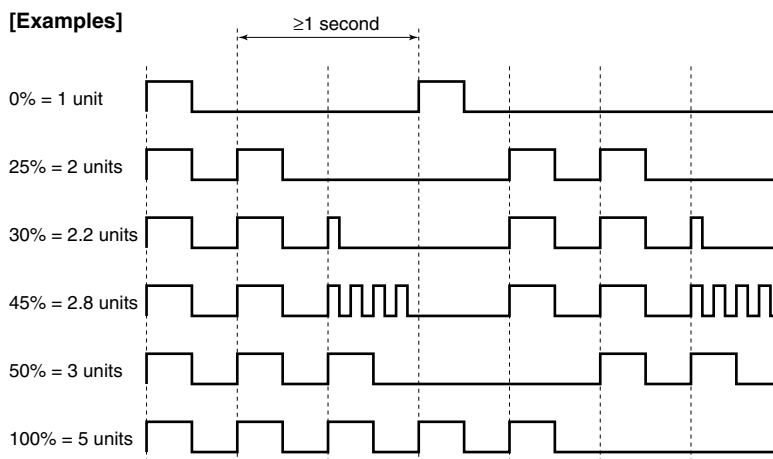
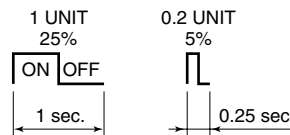

■ **ERROR MONITOR:** Indicates the transmitter's error status.

**Lower overrange:** The input signal is lower than the output's lower range limit.

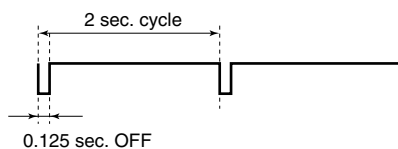

**Upper overrange:** The input signal is higher than the output's upper range limit.

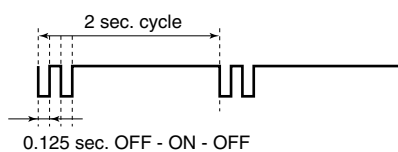

**Burnout:** Sensor wire breakdown is detected.



**Internal error:** The CPU detects an internal error.

