

TIME DELTA SERIES

ULTRASONIC FLOWMETER <TIME DELTA-C>

DATA SHEET

FSV-3, FSS, FLY

This flowmeter is a clamp-on type ultrasonic flow meter based on transit-time measuring method.

Making full use of the latest electronics and digital signal processing technologies, we realized a compact and light-weight design, and improved the accuracy and easiness to use while keeping with anti-bubble performance.

The communication function (MODBUS: Option) is also applicable.

FEATURES

1. High accuracy

The flowmeter is designed for high accuracy (better than $\pm 1.0\%$ of rate) by dynamic correction of fully-developed flow profile. Reynolds Number is calculated and a meter factor (K) is automatically applied for best accuracy at all flow velocities. Further, the adoption of new sound velocity measurement system permits measurements of fluids of unknown sound velocity. Moreover, affection from fluid temperature and pressure is negligible (Auto-Temp./Press. compensation).

2. Compact and light-weight

Thanks to the adoption of the latest electronics the flow transmitter size and mass are 1/3 of our traditional instrument.

3. Full variety of sensors

The flowmeter can be used with various types of sensors applicable for wide range of pipe size ($\phi 13$ to $\phi 6000$ mm) and fluid temperature (-40 to $+200^\circ\text{C}$).

4. Quick response

With the use of high-speed micro-processor suited for digital signal processing, the fast response time is realized.

5. Multi-lingual

The following languages are supported for display:
Japanese (Katakana), English, German French, and Spanish.

6. Excellent performance and easy operation

LCD and function keys are allowing easy configuration and trouble shooting.

- LCD with back light
- Easy mounting of sensor
- Extendable rail type detector up to $\phi 50$ to $\phi 1200$ mm
- Trouble shooting
- Easy operation with keypad on the front surface of the flow transmitter (FSV...S)



Flow transmitter
(FSV...S)



Flow transmitter
(FSV...H)

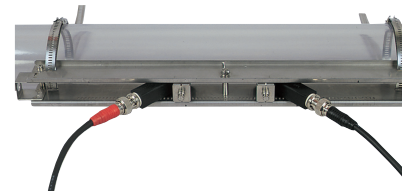

Detector (FSSA)



Detector (FSSC)

SPECIFICATIONS

Operational specifications

System configuration:

Single-path system of a flow transmitter (Model FSV) and a detector (Model FSS)

Applicable detector:

FSSA (2MHz), FSSC (1MHz)

Applicable fluid:

Homogenous liquid where the ultrasonic signal can be transmitted
Bubble quantity: 0 to 12vol% (for pipe size 50A, water, velocity 1m/s)
Fluid turbidity: 10000mg/L max.
Type of flow: Fully-developed turbulent or laminar flow in a full-filled pipe

Flow velocity range:

0 to ± 0.3 ... ± 32 m/s

Power supply: 100 to 240V AC +10%/-15%, 50/60Hz;
or 20 to 30V DC

Signal cable (between detector and converter):
Coaxial cable (150m max.) applicable up
to 300m depending on the condition.
Heat resistance: 80°C

Installation environment:
Non-explosive area without direct sunlight,
corrosive gas and heat radiation.

Ambient temperature:
Flow transmitter: -20 to +55°C
Detector: -20 to +60°C

Ambient humidity:
Flow transmitter: 95%RH max.
Detector: 90%RH max.

Grounding: Class D (100 Ω)

Arrester: Provided as standard at power supply

Applicable piping and fluid temperature: <table 1>

Detector	Pipe size (Inner diameter) ø mm	Applicable pipe material (Note1)	How to mount	Flued temperatur range (°C) (Note2, 3)
FSSA	25 to 50	Plastic (PVC, Others)	V method	-20 to +100
	50 to 225	Plastic (PVC, Others)		
FSSC	50 to 600	Metal pipe (Stainless steel, Carbon steel, Copper, Alu- minum, Others)	V method	-40 to +120
	200 to 1200		Z method	

Note1) Please select the FSSC type if following condition.
 • When pipe material is PP or PVDF, limit of pipe wall thick-
ness is 15mm or more for PP, 9mm or more for PVDF
 • When pipe material is hard to penetrate the ultrasonic
wave such as cast-iron pipe, lining pipe and old carbon
steel pipe etc.,
 • Lining material is tar epoxy, mortar and rubber etc..
 • In case lining is removed from the pipe, Measurement
can not be conducted

Note2) When silicon grease is used as acoustic coupler, Fluid tem-
perature limit is 0 to 60°C no matter what detector is selected.

Note3) Heat-resistant shock temperature: for 30 minutes at 150°C

Note4) Please refer to the item 9 for the specification of the special
detector (for small diameter pipe, large diameter pipe and
high temperature)

Note5) For pipes with a diameter of 300 mm or larger, we recom-
mend to use FSSE and mount it by Z method.

Performance specifications

Rated accuracy: <table 2>

Detector Type	Pipe size (diameter) mm	Flow velocity (m/s)	Accuracy	
			Plastic pipe	Metal pipe
FSSA	ø25 to ø50	2 to 32	±2.0% of rate	-
		0 to 2	±0.04m/s	-
FSSA	ø50 to ø225	2 to 32	±1.0% of rate	±2.0% of rate
		0 to 2	±0.02m/s	±0.04m/s
FSSC	ø50 to ø200	2 to 32	±1.5% of rate	-
		0 to 2	±0.03m/s	-
	ø200 to ø1200	2 to 32	±1.0% of rate	-
		0 to 2	±0.02m/s	-

Note1) Please refer to the item 9 for the specification of the special
detector (for small diameter pipe, large diameter pipe and
high temperature)

Response time: 1s (standard mode)
0.2s as selected (quick response mode)

Power consumption:
15VA max. (AC power supply)
6W max. (DC power supply)

Functional specifications

Analog signal: 4 to 20mA DC (1 point)
Load resistance: 600Ω max.

Digital output: Forward total, reverse total, alarm,
acting range, flow switch, total switch
assignable arbitrarily
Transistor contact (isolated, open collector)
• Outputs: 2 points
• Normal: ON/OFF selectable
• Contact capacity: 30V DC, 50mA
• Output frequency: 1000P/s max. (pulse
width: 5, 10, 50, 100, 200, 500, 1000ms)

Serial communication (option):
RS-485 (MODBUS), isolated, arrester
incorporated
Connectable quantity: 31 units
Baud rate: 9600, 19200, 38400bps
Parity: None/Odd/Even selectable
Stop bits: 1 or 2 bits selectable
Cable length: 1km max.
Data: Flow velocity, flow rate, forward
total, reverse total, status, etc.

Display device: 2-color LED (Normal: green, Extraordi-
nary: red)
LCD with 2 lines of 16 characters and
back light

Indication language:
Japanese (Katakana)/English/French/
German/Spanish (changeable)

Flow velocity/flow rate indication:
Instantaneous flow velocity, instantaneous
flow rate indication (minus indication for
reverse flow)
Numerals: 8 digits (decimal point is counted
as 1 digit)
Unit: Metric/Inch system selectable

	Metric system	Inch system
Velocity	m/s	ft/s
Flow rate	L/s, L/min, L/h, L/d, kL/d, ML/d, m³/s, m³/min, m³/d, km³/d, Mm³/d, BBL/s, BBL/min, BBL/h, BBL/d, kBBL/d, MBBL/d	gal/s, gal/min, gal/h, gal/d, kgal/d, Mgal/d, ft³/s, ft³/ min, ft³/d, Kft³/d, Mft³/d, BBL/s, BBL/min, BBL/h, BBL/d, kBBL/d, MBBL/d

Note: The "gal" means USgal.

Total indication: Forward or reverse total value indica-
tion (negative indication for reverse
direction)
Numerals: 8 digits (decimal point is counted
as 1 digit)
Unit: Metric/Inch system selectable

	Metric system	Inch system
Total	mL, L, m³, km³, Mm³, mBBL, BBL, KBBL	gal, kgal, ft³, kft³, Mft³, mBBL, BBL, kBBL, ACRE-ft

Configuration: Fully configurable from the 4-key pad
(ESC, △, ▽, ENT)

Zero adjustment: Set zero/Clear available

Damping: 0 to 100s (every 0.1s) for analog output
and flow velocity/flow rate indication

Low flow rate cutoff:
0 to 5m/s in terms of flow velocity

Alarm: Digital output available for Hardware
fault or Process fault

Burnout: Analog output: Hold/Overscale/Under-
scale/Zero selectable
Flow rate total: Hold/Count selectable
Burnout timer: 10 to 900s (every 1s)

Bi-directional range:

Forward and reverse ranges configurable independently.

Hysteresis: 0 to 10% of working range

Working range applicable to digital output

Auto-2 range:

2 forward ranges configurable independently

Hysteresis: 0 to 10% of working range

Working range applicable to digital output

Flow switch:

Lower limit, upper limit configurable independently

Digital output available for status at actuated point

Total switch:

Forward total switching point configurable

Digital output available when actuated

External total preset:

Preset total settable upon contact input setting

Backup of power failure:

backup by non-volatile memory

Physical specifications**Type of enclosure:**

Flow transmitter: FSV...S: IP66

FSV...H: IP67 (With large LCD)

Detector:

FSSA, FSSC:

IP65 (When waterproof BNC connector is provided)

FSSA, FSSC:

IP65 (When water-proof type connector is fitting)

FSSC (waterproofing):

IP68 (submerged resistant structure for 5days)

Mounting method:

Flow transmitter: Mounted on wall or by 2B pipe

Detector: Clamped on pipe surface

Acoustic coupler:

Acoustic coupler is a filling between detector and pipe.

Type of acoustic coupler: <table 3>

Type	Silicone rubber (KE-348W)	Silicone grease (G40M)	Silicone-free grease (HIGH Z)	Grease for high temperature (KS62M)
Fluid temperature	-40 to +150°C	-30 to +150°C	0 to +60°C	-30 to +250°C
Teflon piping	×	○	○	○

In case of Teflon piping, use grease.

Material:

Flow transmitter: Aluminum alloy

Detector: <table 4>

Detector Type	Sensor housing	Guide rail
FSSA	PBT	SUS304
FSSC	PBT	Aluminum alloy

* Please refer to the item 9 for the specification of the special detector (for small diameter pipe, large diameter pipe and high temperature)

Signal cable:

- Structure: Heat-resisting high-frequency coaxial cable
- Sheath: Flame-resisting PVC
- Outer diameter: ϕ 7.3mm

Terminal treatment

<table 5>

Cable type	FLYD
Applicable detector	FSSA, FSSC
Terminal of flow transmitter side	Rod terminal \times 2 Amplifier terminal (M3) \times 1
Terminal of detector side	BNC connector \times 1 Amplifier terminal (M4) \times 1

* Please refer to the item 9 for the specification of the special detector (for small diameter pipe, large diameter pipe and high temperature)

Dimension, Mass:

<table 6>

	Type	Dimensions	Mass.(kg)
Flow transmitter	FSV...S (IP66) FSV...H (IP67)	H170 \times W142 \times D70mm H277 \times W244 \times D96mm	1.5 4.5
Detector	FSSA FSSC	H50 \times W348 \times D34mm H88 \times W480 \times D53mm	0.4 1
Signal cable	FLYD	ϕ 7.3mm	90g/m

* Please refer to the item 9 for the specification of the special detector (for small diameter pipe, large diameter pipe and high temperature)

External terminal of flow transmitter:

plug terminal

EU Directive Compliance

CE

LVD (2014/35/EU)

EN 61010-1:2010+A1:2019

EMC (2014/30/EU)

EN 55011:2016+A1:2017+A11:2020+A2:2021, Group 1, Class A

EN IEC 61000-3-2:2019+A1:2021

EN 61000-3-3:2013+A1:2019+A2:2021

EN IEC 61326-1:2021, Table2

EN IEC 61326-2-3:2021

RoHS (2011/65/EU)+(EU)2015/863)

EN IEC 63000:2018

PC Loader software

You can download the software from the Fuji Electric website. Loader software is not covered by quality assurance.

•PC/AT compatible computer

•Main functions: Software for displaying and changing various product parameters and collecting measurement data

Instantaneous flow rate, instantaneous flow velocity, total values, and error information, etc. can be imported.

•OS (verified): Windows 10 (32-bit, 64-bit), Windows 11 (64-bit)

•Memory requirement: 125MB or more

•Hard disk capacity: Minimum available capacity of 52MB or more

Note: To use serial communication, the 6th digit of the product code symbol must be selected as "D". (optional)

Note: Communication converter

To connect the flowmeter to the PC with USB interface, a USB RS-485 converter is required.

<Recommendation>

[USB - RS-485 converter]

Model number: SI-35USB-2 LINEEYE CO., LTD.

MEASURING PRINCIPLE

With ultrasonic pulses propagated diagonally between the upstream and downstream sensors, flow rate is measured by detecting the time difference obtained by the flow of fluid.

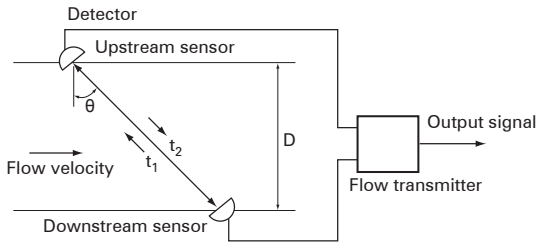

CONFIGURATION DIAGRAM

(1) Single-path system (V method)

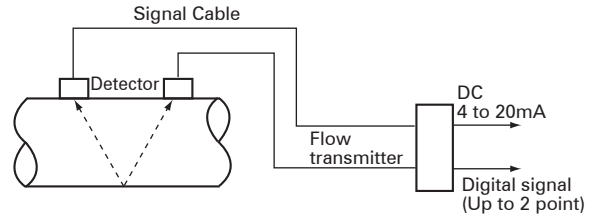

(2) Single path system (Z method)

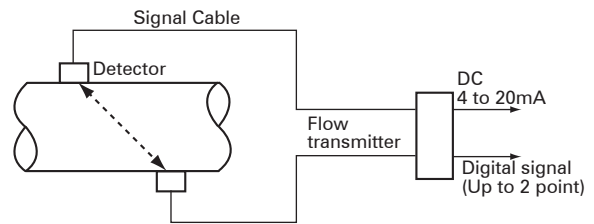

MOUNTING OF DETECTOR

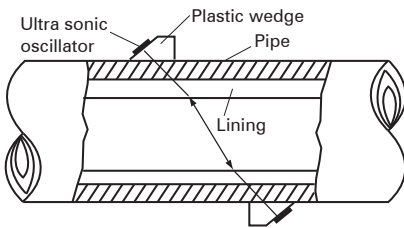

Conditions on straight pipe

(D : Inside diameter of pipe)

Classification	Upstream side	Downstream side
90 bend		
Tee		
Diffuser		
Reducer		
Various Valve		
Pump		

(Note) The source : JEMIS-032

CODE SYMBOL

<Flow transmitter>

1	2	3	4	5	6	7	8	9	10	11	12	13
F	S	V	E	Y	3	-		Y				
Description												
				(Destination) (4th digit) Standard (Japanese) Standard (English)								
				(Communication) (5th digit) None RS485								
				(Use) (6th digit) Single measuring path								
				(Power supply) (7th digit) AC100 to 240V 50/60Hz DC20 to 30V								
				Revision No. (8th digit)								
				(Case structure) (9th digit) IP66 IP67								
				(Wire connection port) (10th digit) Weatherproof gland provided [G1/2 and G3/8 (internal threads)] Union (for pilica) with gland [G1/2 female screw] (when "H" is specified 9th digit)								
				(Combination with explosion-proof detector) (11th digit) None								
				(Parameter setting) (12th digit) None Setting provided Setting provided + tag Tag								
				(Mounting method) (13th digit) Pipe mount (if the 9th digit is S) Wall mount Pipe mount (if the 9th digit is H)								

<Detector>

1	2	3	4	5	6	7	8	9	10
F	S	S	A	1		1	-	Y	
Description									
				<Sensor type> (4th digits) ø25 to ø225mm (V method)					
				<Guide rail> (5th digits) Provided					
				<Mounting belt> (6th digits) None Stainless belt (1.0m × 2)					
				<Acoustic coupler> (7th digit) *1 None Silicon rubber Silicon-free grease Silicon grease					
				-					
				<Tag plate> (10th digit) None Provided					

*1) Normally select silicone rubber as acoustic coupler. Silicone rubber in tube (100g) is furnished. If you place an order for several units, 1 tube may suffice for every 5 units. Select silicone-free grease for semiconductor manufacturing equipment or the like that is vulnerable to silicone. The silicone-free grease is water-soluble and, therefore, cannot be used in environment exposed to water or on piping subjected to a condensation. Since the grease does not set, a periodic maintenance (cleaning, refilling every about 6 months at normal temperature) is necessary.

<Detector>

1	2	3	4	5	6	7	8	10	11	
F	S	S	C	1		1	-			
Description										
				<Sensor type>(4th digits) ø50 to ø1200mm						
				<Guide rail>(5th digits) Provided (Extendable rail type)						
				<Mounting belt>(6th digits) *2 None Stainless belt (1.0m×2) SS belt fasten with screws (1.0m×4) Wire ≤ ø1500mm						
				<Acoustic coupler> (7th digit) *1 None Silicon rubber (KE348) Silicone-free grease (HIGH-Z) Silicone grease (G40M)						
				<Watwe-proof treatment>(9th digit) None Provided (with signal cable 10m)						
				<Tag plate> (10th digit) None Provided						

*2) Please refer to the table 8 to select the mounting belt at 6th digits.

[Table 8] How to select at 6th digits.

Mounting method	≤ø300mm	≤ø600mm	≤ø1200mm
V method	A or C	C	D
Z method	C	D	D

Explanation of the extendable rail type detector

■ Unextended condition



available pipe diameter up to ø50 to ø300mm
<V method>

■ Extended condition



available pipe diameter up to ø600mm
<V method>

■ Installation of the supplied rail end.



available pipe diameter up to ø1200mm
<Z method>

Belt appearance for attachment of the detector.

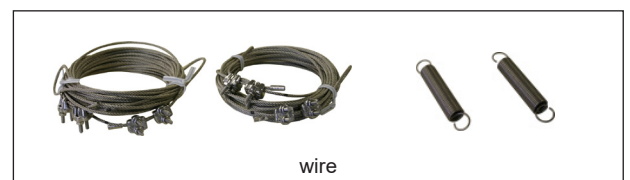
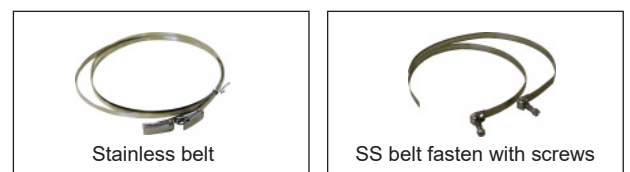

<Signal cable>

1	2	3	4	5	6	7	8	Description
F	L	Y	D				1	Type of sensor (4th digit) for FSSA, FSSC, FSSD, FSSH, FSSE
			D					Cable length (5,6 and 7th digit)
			0	0	5			5 m
			0	1	0			10 m
			0	1	5			15 m
			0	2	0			20 m
			0	2	5			25 m
			0	3	0			30 m
			0	3	5			35 m
			0	4	0			40 m
			0	4	5			45 m
			0	5	0			50 m
			0	5	5			55 m
			0	6	0			60 m
			0	6	5			65 m
			0	7	0			70 m
			0	7	5			75 m
			0	8	0			80 m
			0	8	5			85 m
			0	9	0			90 m
			0	9	5			95 m
			1	0	0			100 m
			1	1	0			110 m
			1	2	0			120 m
			1	3	0			130 m
			1	4	0			140 m
			1	5	0			150 m
			Z	Z	Z			Others (contact us)

Note) When detector is FSSA, length of signal cable is up to 60m.

OUTLINE DIAGRAM (Unit:mm)

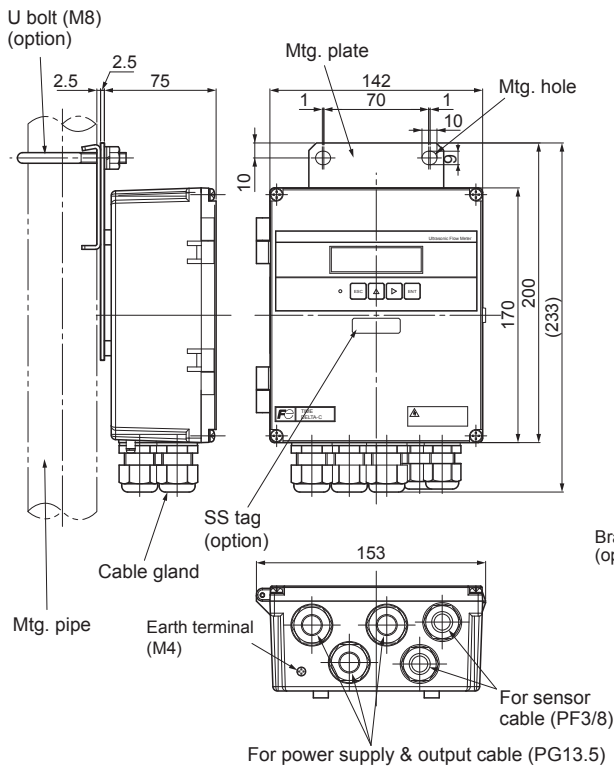

Flow transmitter : FSV...S (IP66)

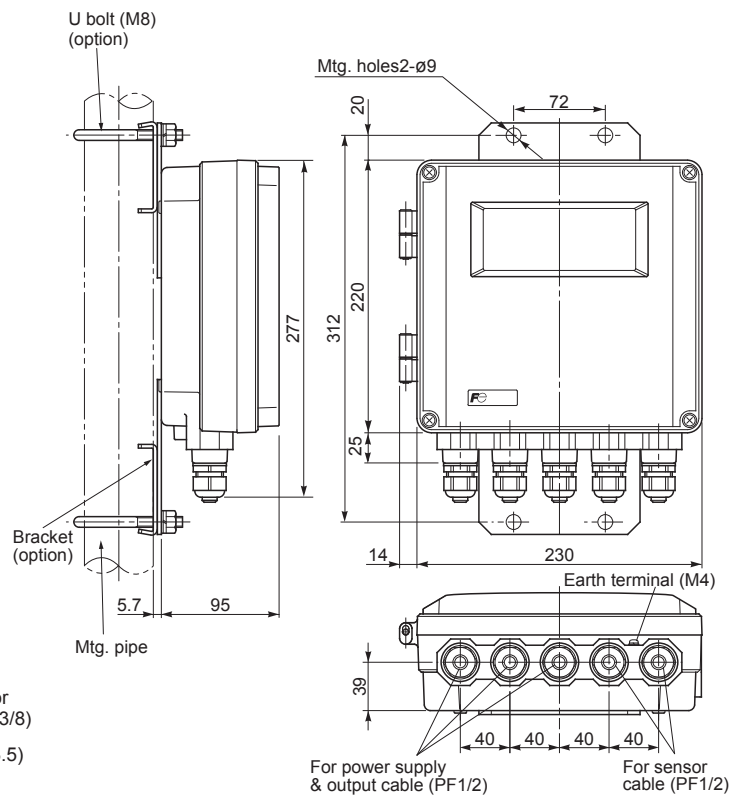

Flow transmitter : FSV...H (IP67)

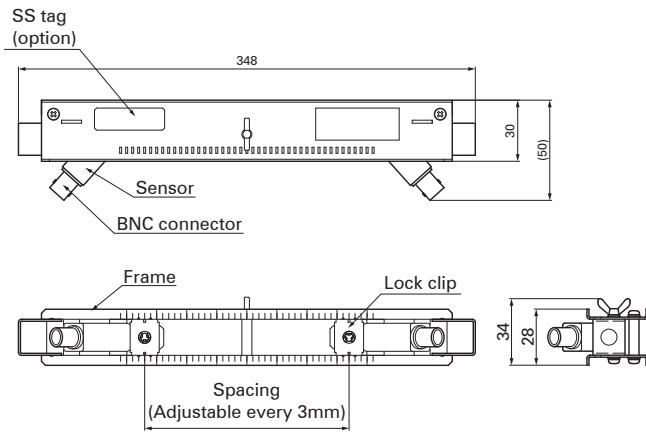

Detector : Type FSSA

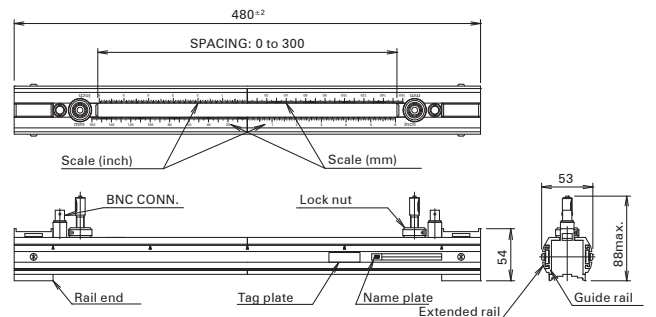

<Shipment style (V method)>

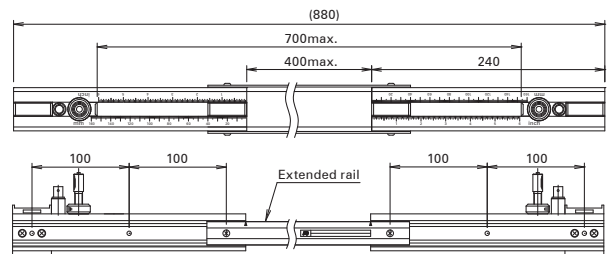

<Extended style (Longest, V method)>

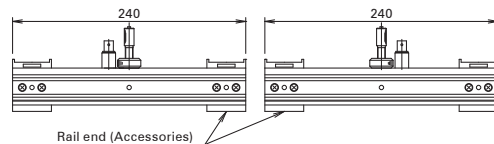

<Separate style (Z method)>

Detector : Type FSSC

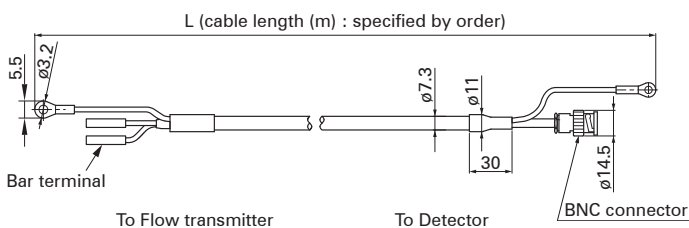

Signal cable : Type FLYD

CONNECTION DIAGRAM

<Flow transmitter>

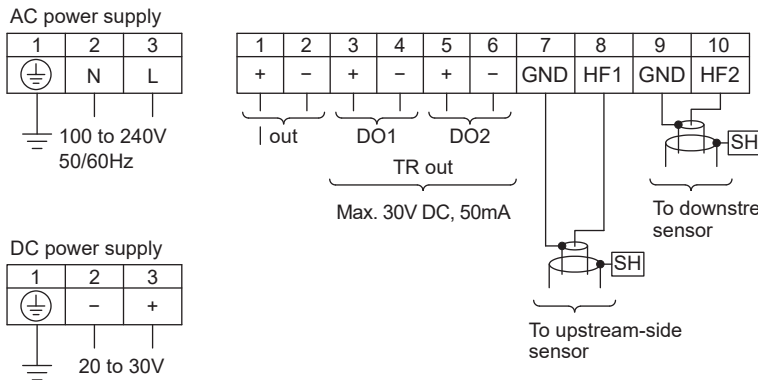

<Detector>

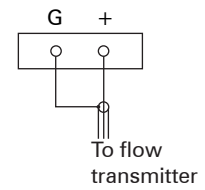

Usable wiring material

• Wire

Gauge: AWG20 (0.5mm²) to AWG16 (1.5mm²)
Strip-off length: 10mm

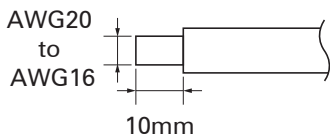

• Bar terminal

Weidmüller
www.weidmuller.com

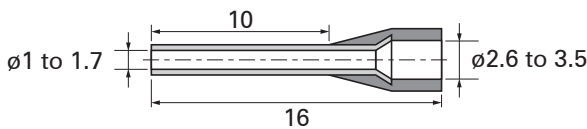

SCOPE OF DELIVERY

- Flow transmitter (provided with U-bolt and nuts for pipe mount)
- Detector (provided with mounting fixture and acoustic coupler)
* The acoustic coupler is option for popular type detectors.
- Signal cable
- Safety Precautions
Please download the instruction manual and PC communication loader software from the measuring instrument website listed at the end of this data sheet.

ITEMS DESIGNATED ORDERING

1. Detector code symbols
2. Flow transmitter code symbols
3. Signal cable code symbols
4. Tag No. as necessary (up to 8 alphanumeric characters)
5. If parameter setting is specified, send back the attached parameter specification table duly filled.

OPTIONAL ACCESSORIES

	Name	Drawing No.
1	Silicone grease (G40M)	ZZP*45231N5
2	Silicone rubber (KE348W)	ZZP*45735N2
3	Silicone-free grease (HIGH-Z)	ZZP*TK7M0981P1

Checked items before purchase

Following conditions may cause failure of the measurement or to reduce the accuracy by this flow meter. Please consult and ask Fuji Electric for checking with actual equipment previously if you have hard to judge the appropriate application.

1) Fluid

- If fluid contains a large amount of bubbles (approx. 12vol% or more at 1m/s flow rate)
- If fluid has bad turbidity 10000(mg/L) or more
- If fluid contains slurry or solid materials (about 5wt%)
- If flow rate is low Reynolds No.10000 or less (reference: flow rate 5m³/h with ø100mm)
- If it is circulating oil, liquid medicine of low concentration, waste liquid and hot spring

2) Pipe

- If inside pipe is rusty carbon steel pipe
- If inside pipe having adhering substances and sediment
- If outer surface of cast-iron pipe is rough
- If pipe wall is tick such as ruinous pipe, (PP material 15mm or more, PVDF material 9mm or more)
- If it is SGPW pipe
- If lining pipe is removed from pipe, (Teflon, PVC, Glass)
- If it is rubber pipe

3) Length of the straight pipe

- For accurate measurement, straight pipes are needed between up and down stream side of the measuring part.
- Please meet the straight pipe conditions according item4.

Caution on use

- 1) Do not damage the sensor or signal mounted on the pipe.
- 2) Make sure to fill the fluid inside the pipe to measure.
- 3) When you use horizontal pipe, it is recommended to install the sensor horizontally.
- 4) When you use the grease as acoustic coupler to install the sensor for outdoor use, it is recommended to install the waterproof cover to prevent from the degradation.

Detector for special application

1) detector for small diameter type

Pipe size: $\phi 13$ to 100mm

Fluid temperature: -40 to 100°C

Type: FSSD1□□1-Y□

Specification

- Sensor frequency: 2MHz
- Mounting method: V method
- Fluid temperature: -40 to 100°C
- Applicable pipe material: PVC, SS, carbon steel pipe, copper pipe, aluminum pipe, etc.
[In case lining is removed from the pipe, Measurement can not be conducted]
- Rated accuracy of combination with the flow transmitter (Applicable piping: plastic, metal pipe)

Internal diameter (mm)	Velocity	Accuracy
$\phi 13 \sim \phi 50$	2 to 32m/s	$\pm 1.5\%$ to $\pm 2.5\%$ of rate
	0 to 2m/s	± 0.03 to ± 0.05 m/s
$\phi 50 \sim \phi 100$	2 to 32m/s	$\pm 1.0\%$ of rate
	0 to 2m/s	± 0.02 m/s

- Mounting belt: according to specified code of symbol.
- Material: PBT, guide rail: aluminum alloy + plastic
- Type of enclosure: IP52
- Acoustic coupler: according to specified code of symbol.
- Mass: 0.6kg

OPTIONAL ACCESSORIES

Name	Drawing No.
Silicon grease (GM40M)	ZZP*45231N5
Silicon rubber (KE348W)	ZZP*45735N2
Silicon-free grease (HIGH-Z)	ZZP*TK7M0981P1

OUTLINE DIAGRAM (unit: mm)

<Detector>

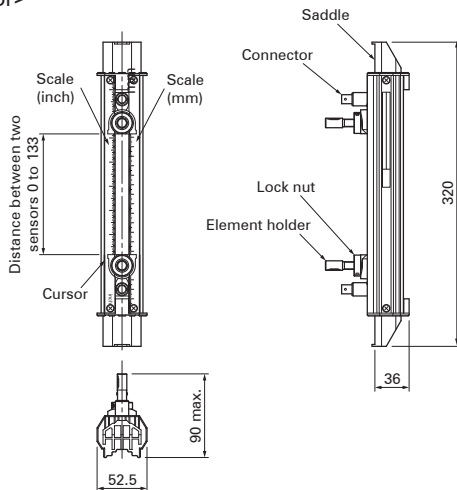

Small diameter sensor: FSSD

<Signal cable>

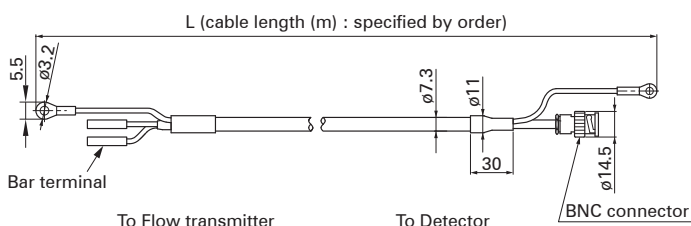

Signal cable : FLYD

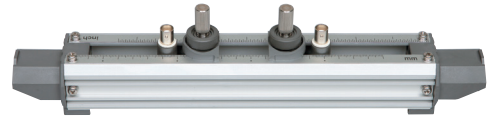

CODE SYMBOL

<Detector>

1	2	3	4	5	6	7	8	10	11	Description
F	S	S	D	1				1	Y	<Sensor type>(4th digits) $\phi 13$ to $\phi 100$ mm
				D						<Guide rail>(5th digits) Provided
					1					<Mounting belt>(6th digits) None Stainless belt (1.0m×2) SS belt fasten with screws (1.0m×4)
						Y				<Acoustic coupler> (7th digit) None Silicon rubber (KE348) Silicone-free grease (HIGH-Z) Silicone grease (G40M)
								Y		<Watwe-proof treatment>(9th digit) None
									Y	<Tag plate> (10th digit) None Provided

<Signal cable>

1	2	3	4	5	6	7	8	Description
F	L	Y	D				1	Type of sensor (4th digit) for FSSA, FSSC, FSSH, FSSD, FSSE
				D				Cable length (5,6 and 7th digit)
				0	0	5		5 m
				0	1	0		10 m
				0	1	5		15 m
				0	2	0		20 m
				0	2	5		25 m
				0	3	0		30 m
				0	3	5		35 m
				0	4	0		40 m
				0	4	5		45 m
				0	5	0		50 m
				0	5	5		55 m
				0	6	0		60 m
				0	6	5		65 m
				0	7	0		70 m
				0	7	5		75 m
				0	8	0		80 m
				0	8	5		85 m
				0	9	0		90 m
				0	9	5		95 m
				1	0	0		100 m
				1	1	0		110 m
				1	2	0		120 m
				1	3	0		130 m
				1	4	0		140 m
				1	5	0		150 m
				Z	Z	Z		Others (contact us)

Scope of delivery

- Detector, acoustic coupler and set of the mounting belt according to specified code of symbol
- Signal cable according to specified code of symbol

Detector for special application 2) detector for high temperature

Pipe size: $\phi 50$ to 400mm
 Fluid temperature: -40 to 200°C
 Type: FSSH1□□1-Y□

Specification

- Sensor frequency: 2MHz
- Mounting method: V method ($\phi 50$ to 250mm) or Z method ($\phi 150$ to 400mm)
- Fluid temperature: -40 to 200°C
- Applicable pipe material: PVC, SS, carbon steel pipe, copper pipe, aluminum pipe, etc.
 [In case lining is removed from the pipe, Measurement can not be conducted]
- Rated accuracy of combination with the flow transmitter (Applicable piping: plastic, metal pipe)

Internal diameter (mm)	Velocity	Accuracy
$\phi 50 \sim \phi 300$	2 to 32m/s	$\pm 1.0\%$ of rate
	0 to 2m/s	$\pm 0.02\text{m/s}$
$\phi 300 \sim \phi 400$	0.75 to 32m/s	$\pm 1.0\%$ of rate
	0 to 0.75m/s	$\pm 0.0075\text{m/s}$

- Mounting belt: according to specified code of symbol.
- Material: sensor housing: SUS304
 guide rail: SUS304 + aluminum alloy
- Type of enclosure: IP52
- Acoustic coupler: according to specified code of symbol.
- Mass: 1.6kg

OPTIONAL ACCESSORIES

Name	Drawing No.
Guide rail for high-temperature sensor (Z method)	ZZP*TK4J5917C3
High-temperature grease(KS62M)	ZZP*TK7G7983C1

OUTLINE DIAGRAM (unit: mm)

<Detector>

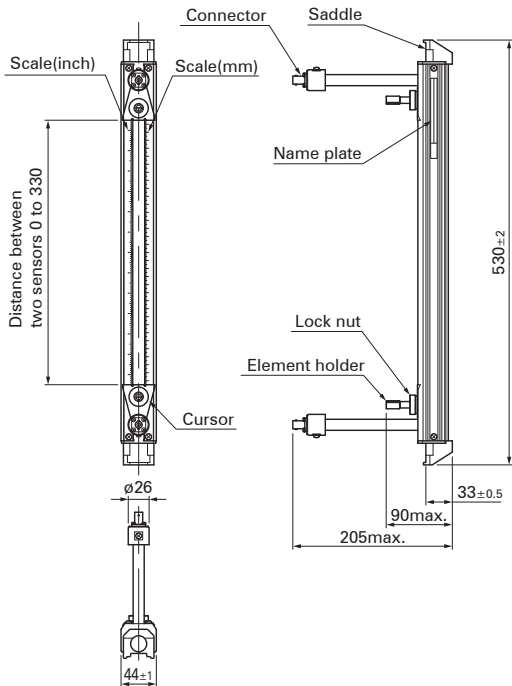

High-temperature sensor: FSSH

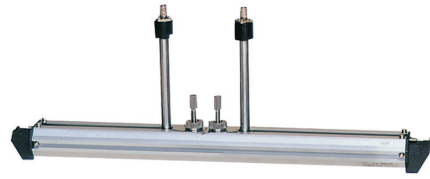

CODE SYMBOL

<Detector>

1	2	3	4	5	6	7	8	10	11	Description
F	S	S	H	1				1	Y	<Senser type>(4th digits) $\phi 50$ to $\phi 400\text{mm}$ (-40 to 200°C)
			H							<Guide rail>(5th digits) Provided
				1						<Mounting belt>(6th digits) None Stainless belt (1.0m×2) SS belt fasten with screws (1.0m×4)
					Y					<Acoustic coupler> (7th digit) None High-temperature grease (KS62M)
						D				<Watwe-proof treatment>(9th digit) None
								Y		<Tag plate> (10th digit) None Provided

<Signal cable>

1	2	3	4	5	6	7	8	Description
F	L	Y	D				1	Type of sensor (4th digit) for FSSA, FSSC, FSSH, FSSD, FSSE
			D					Cable length (5,6 and 7th digit)
				0	0	5		5 m
				0	1	0		10 m
				0	1	5		15 m
				0	2	0		20 m
				0	2	5		25 m
				0	3	0		30 m
				0	3	5		35 m
				0	4	0		40 m
				0	4	5		45 m
				0	5	0		50 m
				0	5	5		55 m
				0	6	0		60 m
				0	6	5		65 m
				0	7	0		70 m
				0	7	5		75 m
				0	8	0		80 m
				0	8	5		85 m
				0	9	0		90 m
				0	9	5		95 m
				1	0	0		100 m
				1	1	0		110 m
				1	2	0		120 m
				1	3	0		130 m
				1	4	0		140 m
				1	5	0		150 m
				Z	Z	Z		Others (contact us)

Scope of delivery

- Detector, acoustic coupler and set of the mounting belt according to specified code of symbol
- Signal cable according to specified code of symbol

<Signal cable>

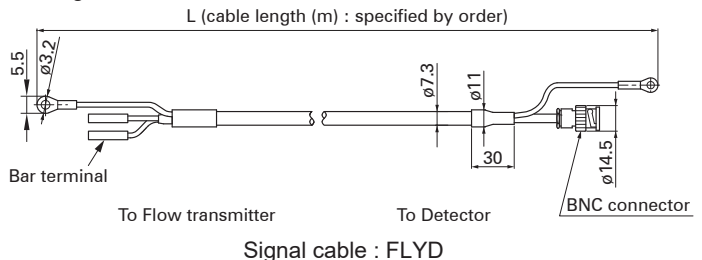

Detector for special application

3) detector for large diameter type

Pipe size: $\phi 200$ to 6000mm
 Fluid temperature: -40 to 80°C
 Type: FSSE1□□1-□□



Specification

- Sensor frequency: 0.5MHz
- Mounting method: V or Z method
- Fluid temperature: -40 to 80°C
- Applicable pipe material: PVC, SS, carbon steel pipe, copper pipe, aluminum pipe, etc.
 - * In case lining is removed from the pipe, Measurement can not be conducted
- Also applicable to water-proof type according to specified code of symbol (submerged resistant structure for 5days including 10m cable)
- Rated accuracy of combination with the flow transmitter (Applicable piping: plastic, metal pipe)

Internal diameter (mm)	Velocity	Accuracy
$\phi 200 \sim \phi 300$	2 to 32m/s	$\pm 1.5\%$ of rate
	0 to 2m/s	$\pm 0.03\text{m/s}$
$\phi 300 \sim \phi 1200$	0.75 to 32m/s	$\pm 1.5\%$ of rate
	0 to 0.75m/s	$\pm 0.0113\text{m/s}$
$\phi 1200 \sim \phi 6000$	1 to 32m/s	$\pm 1.0\%$ of rate
	0 to 1m/s	$\pm 0.02\text{m/s}$

- Mounting belt: according to specified code of symbol.
- Material: Sensor housing PBT, Sensor cover SUS304
- Type of enclosure: IP67
 (silicon rubber is filled up on the terminal block when connecting work)
- Acoustic coupler: according to specified code of symbol.
- Mass: 1.2kg

OPTIONAL ACCESSORIES

Name	Drawing No.
Wire rope for mounting the sensor	
• Spring	ZZP*TK745007P1
• Wire rope (up to $\phi 500\text{mm}$)	ZZP*TK464686C1
• Wire rope (up to $\phi 1000\text{mm}$)	ZZP*TK464686C2
• Wire rope (up to $\phi 1500\text{mm}$)	ZZP*TK464686C3
• Wire rope (up to $\phi 3000\text{mm}$)	ZZP*TK464686C6
• Wire rope (up to $\phi 6000\text{mm}$)	ZZP*TK464686C13
Silicon grease (GM40M)	ZZP*45231N5
Silicon rubber (KE348W)	ZZP*45735N2
Silicon-free grease (HIGH-Z)	ZZP*TK7M0981P1

OUTLINE DIAGRAM (unit: mm)

<Detector>

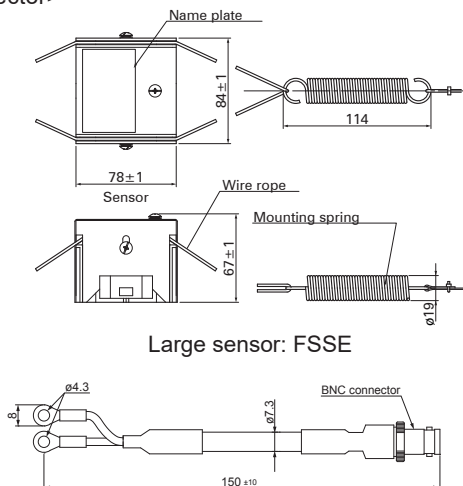

Large sensor: FSSE

Signal cable conversion cord (accessories)

CODE SYMBOL

<Detector>

1	2	3	4	5	6	7	8	10	11	Description
F	S	S	E	1						<Sensor type> (4th digits) $\phi 200$ to $\phi 6000\text{mm}$
				E						<Guide rail> (5th digits) Provided
				1						<Mounting belt> (6th digits) None Wire $\leq \phi 1500\text{mm}$ Wire $\leq \phi 6000\text{mm}$
				Y						<Acoustic coupler> (7th digit) None Silicon rubber (KE348) Silicone-free grease (HIGH-Z) Silicone grease (G40M)
				A						<Watwe-proof treatment> (9th digit) None Provided (with signal cable 10m)
				B						<Tag plate> (10th digit) None Provided
				C						

<Signal cable>

1	2	3	4	5	6	7	8	Description
F	L	Y	D				1	Type of sensor (4th digit) for FSSA, FSSC, FSSH, FSSD, FSSE
			D					Cable length (5,6 and 7th digit)
				0	0	5		5 m
				0	1	0		10 m
				0	1	5		15 m
				0	2	0		20 m
				0	2	5		25 m
				0	3	0		30 m
				0	3	5		35 m
				0	4	0		40 m
				0	4	5		45 m
				0	5	0		50 m
				0	5	5		55 m
				0	6	0		60 m
				0	6	5		65 m
				0	7	0		70 m
				0	7	5		75 m
				0	8	0		80 m
				0	8	5		85 m
				0	9	0		90 m
				0	9	5		95 m
				1	0	0		100 m
				1	1	0		110 m
				1	2	0		120 m
				1	3	0		130 m
				1	4	0		140 m
				1	5	0		150 m
				Z	Z	Z		Others (contact us)

Scope of delivery

- Detector, Signal cable conversion cord, acoustic coupler and set of the mounting belt according to specified code of symbol
- Signal cable according to specified code of symbol

<Signal cable>

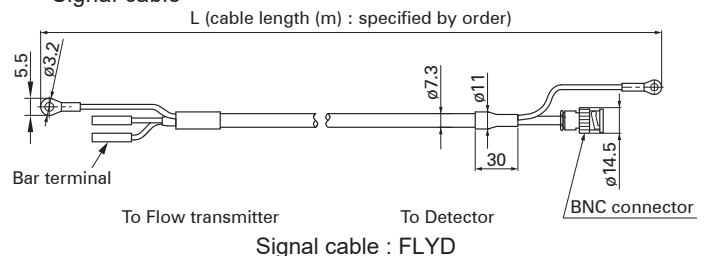

<Parameter specification table>

Setting item		Initial value	Setting value	Setting item		Initial value	Setting value			
ID No		0000		Total output		Total mode	Stop			
Language		English				Total rate	0m ³			
Measuring conditions	System unit	Metric				Total preset	0m ³			
	Flow unit	m ³ /h				Pulse width	50.0msec			
	Total unit	m ³				Burnout (total)	Hold			
	Outer diameter	60.00mm		Burnout timer	10sec					
	Pipe material	PVC pipe		Output conditions		DO1 output type (Note 1)	Not used			
	Wall thickness	4.00mm				DO1 output actuation	ON when actuated			
	Lining material	Without lining				DO2 output type	Not used			
	Lining thickness	-				DO2 output actuation	ON when actuated			
	Kind of fluid	Water				Operation mode	Standard			
	Viscosity	1.0038 × 10 ⁻⁶ m ² /s								
	Sensor mount	V method								
	Sensor type	FSSA								
	Output conditions		Damping			5.0sec	Communication		Communication mode	RS-485
Cut off			0.150m ³ /h			Baud rate			9600bps	
Display			1st line			Flow velocity (m/s)			Parity	Odd
			1st line decimal point position			****.***			Stop bit	1 bit
2nd line			Flow rate (m ³ /h)			Station No.			1	
2nd line decimal point position			****.***							
Analog output			Range kind	Flow rate						
			Range type	Single range						
			Full scale 1	15.000m ³ /h						
			Full scale 2	0.000m ³ /h						
			Range HYS.	10.00%						
			Burnout (current)	Hold						
			Burnout timer	10sec						
	Output low limit	-20%								
Output high limit	120%									
Rate limit	0.000m ³ /h									
Rate limit timer	0sec									

Note1: When total pulse output has been selected for DO1, DO2 specify total pulse value and total pulse width so that conditions 1 and 2 shown below are satisfies.

$$\text{Condition 1 : } \frac{\text{Flow span-1} \cdot [\text{m}^3/\text{s}]}{\text{total pulse value} \cdot [\text{m}^3]} \leq 100[\text{Hz}]$$

$$\text{Condition 2 : } \frac{\text{Flow span-1} \cdot [\text{m}^3/\text{s}]}{\text{total pulse value} \cdot [\text{m}^3]} \leq \frac{1000}{2 \times \text{total pulse width} [\text{ms}]}$$

* In the case of 2 ranges, perform calculations using either flow span-1 or flow span-2, whichever is greater.

Information in this catalog is subject to change without notice.
Read the instruction manuals thoroughly before using the products.



Gate City Ohsaki, East Tower, 11-2, Osaki 1-chome, Shinagawa-ku, Tokyo 141-0032, Japan
Phone: +81-3-5435-7111
www.fujielectric.com
www.fujielectric.com/products/sensors_measurements/instruments/index.html

