

Single Loop Controller Series

MULTI-FUNCTION PID CONTROLLER

(color LCD with touch-panel)

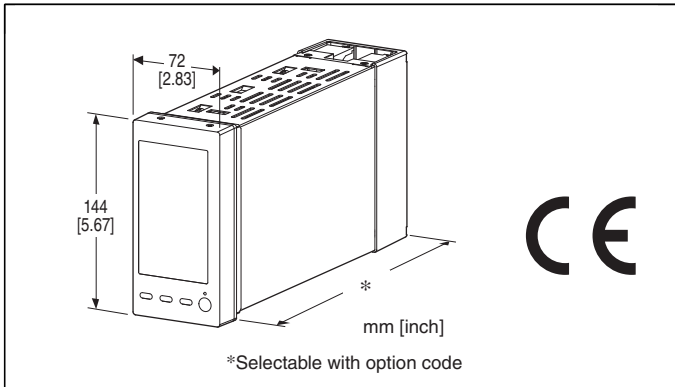

/4: 400 mm

/6: 600 mm

Language

blank: Japanese

/E: English

(Language (Japanese or English) can be chosen by front panel setting.)

Configurator Interface

blank: Infrared (Discontinued, select /1)

/1: Stereo jack

Terminal block

blank: One block terminal (Discontinued, select /T)

/T: Separable terminal

Edition

blank: Edition 0 (RAM memory duration in power failure for hot start: 10 minutes or more, Discontinued, select /E1)

/E1: Edition 1 (RAM memory duration in power failure for hot start: no limit)

Other Options

blank: none

/Q: Option other than the above (specify the specification)

MODEL: PSC100-[1]0-[2][3]

ORDERING INFORMATION

• Code number: PSC100-[1]0-[2][3]

Specify a code from below for each of [1] through [3].

(e.g. PSC100-10-M2/3/E/1/T/E1/Q)

• Specify the specification for option code /Q

(e.g. /C01/S01)

SPECIFICATIONS OF OPTION: Q (multiple selections)

COATING (For the detail, refer to our web site.)

/C01: Silicone coating

/C02: Polyurethane coating

/C03: Rubber coating

TERMINAL SCREW MATERIAL

/S01: Stainless steel

[1] DISCRETE OUTPUT

1: Relay contact

2: Photo MOSFET relay

MODBUS

0: None

[2] POWER INPUT

AC Power

M2: 100 - 240 V AC (Operational voltage range 85 - 264 V, 50/60 Hz)

DC Power

R: 24 V DC

(Operational voltage range 24 V \pm 10 %, ripple 10 %p-p max.)

[3] OPTIONS (multiple selections)

Housing Depth

blank: 250 mm

/300: 300 mm (Discontinued, select /3)

/400: 400 mm (Discontinued, select /4)

/600: 600 mm (Discontinued, select /6)

/3: 300 mm

FUNCTIONS & FEATURES

Functions & Features

- Color LCD with touch panel
- Four Operation views (digital display, bargraph, dual-loop bargraph and short trend views)
- Enhanced screen functions for engineering (configuration, programming and tuning views)
- Universal input x 2 points, analog input x 4 points, discrete input x 6 points, pulse input x 5 points, high speed pulse input x 1 point
- Current output (4-20 mA) x 2 points, voltage output (1-5 V) x 2 points, relay or photo-MOSFET relay output x 5 points
- RUN output (relay) x 1 point
- Computation cycle selectable between 50 msec. and 3 sec. (control cycle selectable between 1 and 64 times of the computation cycle)
- Two PID function blocks
- Advanced computation and sequence control functions
- Auto-tuning function
- Parameter input and changing with touch panel
- Function parameter setting, list printing and data

downloading/uploading available with Loop Configuration Builder Software (model:PSFEW)

- Display parameter setting, saving and transfer with PC Configurator Software (model: PSCCFG)
- Selectable housing depth for ease of using existing wires in replacement: 250 mm, 300 mm, 400 mm and 600 mm
- Separable terminal block

Typical Applications

- Replacement of conventional controllers
- Panel operation for small-scale instrumentation

RELATED PRODUCTS

- PC Configurator cable (model: COP-US)
- Loop configuration builder software (model: PSFEW Ver. 1.112 or later)
- PC configurator software (model: PSCCFG Ver.1.80 or later)

ACCESSORIES

- Precision resistor module (model: REM4): 2
 - Cold junction sensor: 2
 - Mounting brackets: 2
 - Connector adapter: 1
- (The jack on the unit and the plug of PC Configurator cable (not included in the product) are different in size.)

GENERAL SPECIFICATIONS

Construction: Panel flush mounting

Degree of protection: IP55; ensured for the front panel of the unit independently mounted to a panel

Connection

Terminal screws: M3.5 screw terminals (torque 1.0 N·m)

Terminal fixing screws: M4 screw terminals (torque 1.2 N·m)

Screw terminal

Terminal screws: Nickel-plated steel (standard) or stainless steel

Terminal fixing screws: Chrome-plated steel

Housing material: Flame-resistant resin (gray), steel

Isolation: Pv1 to Pv2 to supply output to Ai1 or Ai2 or Ai3 or Ai4 to Di1 or Di2 or Di3 or Di4 or Di5 or Pi1 or Pi2 or Pi3 or Pi4 or Pi5 to Di6 or Pi6 to Mv1 to Mv2 to Ao1 or Ao2 to Do1 to Do2 to Do3 to Do4 to Do5 to Do6 to power to FG

PID control: Single loop, cascade, advanced

Proportional band (P): 1 to 1000 %

Integral time (I): 0.01 to 100 minutes

Derivative time (D): 0.01 to 10 minutes

Auto-tuning: Limit cycle method

Alarm: PV high & low, deviation, rate of change

Computation: 48 functions blocks available for arithmetic

operations, time functions, signal selection, limit, alarm and other functions

Sequence operation: Logic sequence and step sequence (max. 1068 commands)

Computation cycle: 50 msec. to 3 sec. (control cycle selectable among 1, 2, 4, 8, 16, 32 and 64 times of the computation cycle)

MV output range: -15 - +115 %

Parameter setting: With touch panel or PC (Loop Configuration Builder Software model: PSFEW)

Self diagnostics: CPU monitoring with a watchdog timer

RUN contact: OFF in error detected by diagnostic

Display

Display device: 4.3-inch TFT LCD

Display colors: 256

Resolution: 480 × 272 pixels

Pixel pitch: 0.198 × 0.198 mm (128 × 128 DPI)

Backlight: LED

Backlight life: Approx. 50 000 hours (at 50 % brightness)

Note: The backlight can be replaced in our factory.

The LCD must be replaced at the same time.

Screen saver standby time: 1 to 99 minutes

Scaling range: -32000 to +32000

Decimal point position: 10⁻¹, 10⁻², 10⁻³, 10⁻⁴, 10⁻⁵ or none

Scale divisions: 2 to 10

Engineering unit indication: Max. 8 characters

Auto/Man indicator: Green/Amber LED

FACTORY DEFAULT

LOOP 1

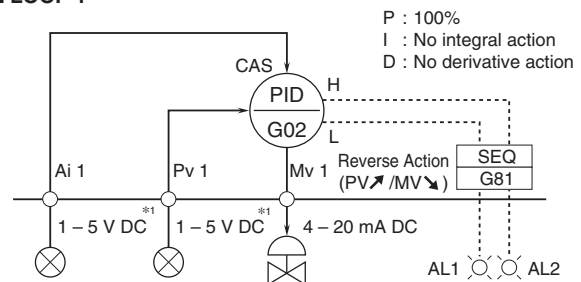

LOOP 2

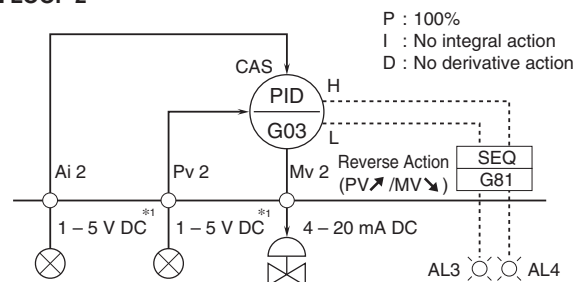

*1. Factory default setting

Use Loop Configuration Builder Software (model: PSFEW) to modify setting.



SUPPLY OUTPUT

Output voltage:24 V DC $\pm 10\%$ with no load

18 V DC min. at 20 mA

Current rating: ≤ 22 mA DC• **Shortcircuit protection****Current limited:** Approx. 30 mA

INPUT SPECIFICATIONS

■ **Pv1, Pv2 (universal input)**• **Current input:** 4 - 20 mA DC with input resistance 250 Ω (REM4)• **Voltage input:** -10 - +10 V DC

-1 - +1 V DC

0 - 10 V DC

1 - 5 V DC

0 - 1 V DC

Input resistance: Approx. 1 M Ω • **Thermocouple input:** K, E, J, T, B, R, S, C, N, U, L, P, PR (See Table 1)**Input resistance:** ≥ 30 k Ω **Burnout sensing:** ≤ 0.3 μ A**Burnout indication:** 115 % of the measuring range (upscale)• **RTD input:** Pt100 (JIS '97, IEC), Pt100 (JIS '89), JPt100 (JIS '89), Pt50 Ω (JIS '81), Ni100 (See Table 2)**Maximum lead wire resistance:** 100 Ω per wire**Burnout indication:** 115 % of the measuring range (upscale)**Sensing current:** ≤ 1 mA• **Potentiometer input:** Total resistance 100 Ω to 10 k Ω **Minimum span:** 50 % of total resistance**Excitation:** ≤ 0.6 V DC■ **Ai1, Ai2, Ai3, Ai4**• **Voltage input:** 1 - 5 V DC**Input resistance:** ≥ 1 M Ω ■ **Pi1, Pi2, Pi3, Pi4, Pi5:** Dry contact

(Di1 through Di5 are assigned to the same terminals respectively.)

Maximum frequency: 20 Hz**Minimum pulse width:** 25 msec.**Common:** Negative common per 5 points**Sensing:** Approx. 12 V DC, 6 mA**ON voltage/resistance:** ≤ 2.25 V, ≤ 1.5 k Ω **OFF voltage/resistance:** ≥ 11.25 V ≥ 15 k Ω ■ **Pi6:** Dry contact

(Di6 is assigned to the same terminal.)

Maximum frequency: 10 kHz(Computation cycle: ≤ 500 msec.)**Minimum pulse width:** 0.05 msec.**Common:** Negative common**Sensing:** Approx. 12 V DC, 12 mA**ON voltage/resistance:** ≤ 2 V, ≤ 1.5 k Ω **OFF voltage/resistance:** ≥ 11 V, ≥ 15 k Ω **Excitation:** 12 V DC $\pm 10\%$, 15 mA**Current limiting circuit:** Approx. 30 mA■ **Di1, Di2, Di3, Di4, Di5:** Dry contact

(Pi1 through Pi5 are assigned to the same terminals respectively.)

Common: Negative common per 5 points**Sensing:** Approx. 12 V DC, 6 mA**ON voltage/resistance:** ≤ 2.25 V, ≤ 1.5 k Ω **OFF voltage/resistance:** ≥ 11.25 V ≥ 15 k Ω ■ **Di6:** Dry contact

(Pi6 is assigned to the same terminal.)

Common: Negative common**Sensing:** Approx. 12 V DC, 12 mA**ON voltage/resistance:** ≤ 2 V, ≤ 1.5 k Ω **OFF voltage/resistance:** ≥ 11 V, ≥ 15 k Ω **[Table 1 (Thermocouple input)]**

T/C	USABLE RANGE (°C)	CONFORMANCE RANGE (°C)
K (CA)	-272 to +1472	-150 to +1370
E (CRC)	-272 to +1100	-170 to +1000
J (IC)	-260 to +1300	-180 to +1200
T (CC)	-272 to +500	-170 to +400
B (RH)	24 to 1920	1000 to 1760
R	-100 to +1860	380 to 1760
S	-100 to +1860	400 to 1760
C (WRe 5-26)	-52 to +2416	100 to 2315
N	-272 to +1400	-130 to +1300
U	-252 to +700	-200 to +600
L	-252 to +1000	-200 to +900
P (Platinel II)	-52 to +1496	0 to 1395
(PR)	-52 to +1860	300 to 1760

Overrange input (out of the usable range) is handled as burnout.

[Table 2 (RTD input)]

RTD	USABLE RANGE (°C)	CONFORMANCE RANGE (°C)
Pt 100 (JIS '97, IEC)	-240 to +900	-200 to +850
Pt 100 (JIS '89)	-240 to +900	-200 to +660
JPt 100 (JIS '89)	-236 to +560	-200 to +510
Pt 50 Ω (JIS '81)	-236 to +700	-200 to +649
Ni 100	-100 to +252	-80 to +250

Overrange input (out of the usable range) is handled as burnout.

OUTPUT SPECIFICATIONS

■ **Mv1, Mv2**• **Current output:** 4 - 20 mA DC**Load resistance:** ≤ 600 Ω ■ **Ao1, Ao2**• **Voltage output:** 1 - 5 V DC**Load resistance:** ≥ 10 k Ω ■ **Discrete Output**• **Do1, Do2, Do3, Do4, Do5, RUN contact (Do6):** Relay contact

Rated load: 250 V AC @1 A (cos ϕ = 1)
30 V DC @1 A (resistive load)
Maximum switching voltage: 250 V AC or 30 V DC
Maximum switching power: 250 VA or 60 W
Minimum load: 5 V DC @10 mA
Mechanical life: 2×10^7 cycles
•Do1, Do2, Do3, Do4, Do5: Photo MOSFET relay
Rating: 200 V AC/DC @0.5 A (resistive load)
ON resistance: 2.1 Ω
Maximum frequency: 4 Hz @24 V, 10 mA
ON delay time: ≤ 5.0 msec.
OFF delay time: ≤ 3.0 msec.

25°C
Insulation resistance: ≥ 100 M Ω with 500 V DC
Dielectric strength:
1500 V AC @ 1 minute
(Pv1 or supply output to Pv2 or Ai1 or Ai2 or Ai3 or Ai4 to Di1 or Di2 or Di3 or Di4 or Di5 or Pi1 or Pi2 or Pi3 or Pi4 or Pi5 to Di6 or Pi6 to Mv1 to Mv2 or Ao1 or Ao2 to Do1 to Do2 or Do3 or Do4 or Do5 or Do6 to power to FG)
500 V AC @ 1 minute (Pv2 to Ai1 or Ai2 or Ai3 or Ai4)
500 V AC @ 1 minute (Mv2 to Ao1 or Ao2)
500 V AC @ 1 minute (Do2 to Do3 to Do4 to Do5 to Do6)
500 V AC @ 1 minute (Pv1 to supply output)

INSTALLATION

Power input

- AC:
 ≤ 25 VA at 100 V AC
 ≤ 40 VA at 240 V AC
- DC: ≤ 650 mA

Operating temperature: -5 to +55°C (23 to 131°F)

Operating humidity: 5 to 90 %RH (non-condensing)

Mounting: Panel flush mounting (high-density mounting in horizontal direction)

Weight:

Approx. 2.4 kg (5.29 lb) for 250 mm depth type
Approx. 2.6 kg (5.73 lb) for 300 mm depth type
Approx. 3.1 kg (6.84 lb) for 400 mm depth type
Approx. 3.6 kg (7.94 lb) for 600 mm depth type

PERFORMANCE in percentage of max. span

Accuracy

DC input: ± 0.1 % ± 1 digit
Thermocouple input: $\pm 1^\circ\text{C}$ ± 1 digit
 $\pm 2^\circ\text{C}$ ± 1 digit for B, R, S, C and PR
RTD input: $\pm 1^\circ\text{C}$ ± 1 digit
Potentiometer input: ± 0.2 % ± 1 digit
DC output: ± 0.1 %
Precision resistor module (REM4): ± 0.1 %

Cold junction compensation:

$\pm 2^\circ\text{C}$ at 25°C $\pm 10^\circ\text{C}$
 $\pm 4^\circ\text{C}$ for S, R and PR

Temp. coefficient: ± 0.015 %/ $^\circ\text{C}$ (± 0.008 %/ $^\circ\text{F}$)

DC input: ± 0.015 %/ $^\circ\text{C}$ (± 0.008 %/ $^\circ\text{F}$)
Thermocouple input: ± 0.015 %/ $^\circ\text{C}$ (± 0.008 %/ $^\circ\text{F}$)
RTD input: ± 0.015 %/ $^\circ\text{C}$ (± 0.008 %/ $^\circ\text{F}$)
Potentiometer input: ± 0.015 %/ $^\circ\text{C}$ (± 0.008 %/ $^\circ\text{F}$)
DC output: ± 0.015 %/ $^\circ\text{C}$ (± 0.008 %/ $^\circ\text{F}$)
Precision resistor module (REM4): ± 0.015 %/ $^\circ\text{C}$ (± 0.008 %/ $^\circ\text{F}$)

Line voltage effect: ± 0.1 % over voltage range

Calendar clock accuracy: Monthly deviation 3 minutes at

STANDARDS & APPROVALS

EU conformity:

EMC Directive

EMI EN 61000-6-4

EMS EN 61000-6-2

Low Voltage Directive

EN 61010-1

Measurement Category II (contact output)

Installation Category II (power)

Pollution degree 2

Input or output to contact output - Basic insulation (300 V)

Input or output to power - Basic insulation (300 V)

RoHS Directive

EN 50581

Protection against access to the terminal blocks:

Finger protection (VDE 0660-514)

EXTERNAL VIEW

■ CONTROL MODULE FRONT VIEW

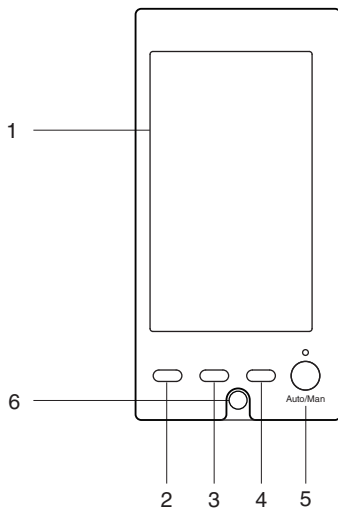

1. TFT Color LCD with touch panel
Provides operation and engineering views to facilitate monitoring and setting
2. MV value (DOWN) button
3. Acceleration button
(Accelerates MV signal's changing speed by pressing simultaneously with MV value button)
4. MV value (UP) button
5. Auto / Man selector (changes the control mode for MV output)
6. Configurator jack and cap
Connects with a PC where Loop Configuration Builder Software (model: PSFEW) or PC configurator software (model: PSCCFG) is installed via a PC configurator cable (model: COP-US) and enables programming and parameter setting

EXTERNAL DIMENSIONS & TERMINAL ASSIGNMENTS unit: mm [inch]

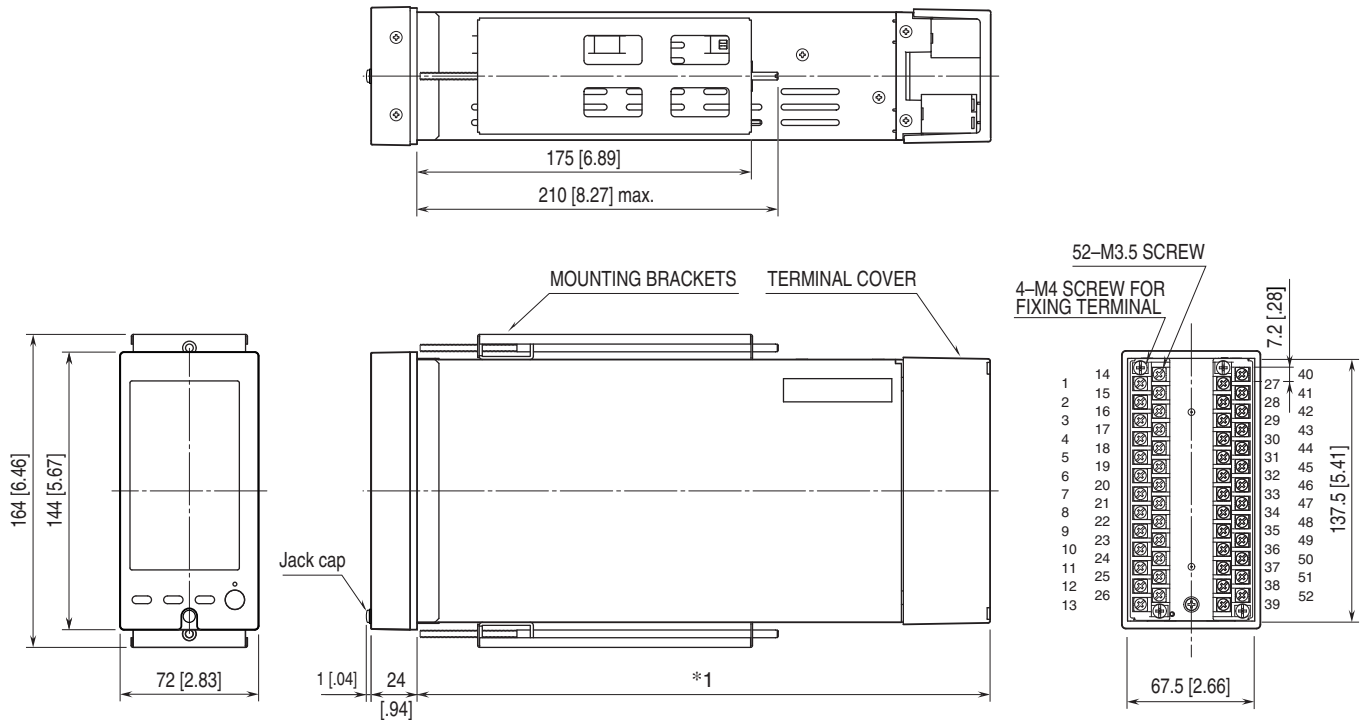

- *1. Standard model: 250 mm [9.84"]
- Option /3: 300 mm [11.81"]
- Option /4: 400 mm [15.75"]
- Option /6: 600 mm [23.62"]

MOUNTING REQUIREMENTS unit: mm

■ PANEL CUTOUT unit: mm

• Single mounting

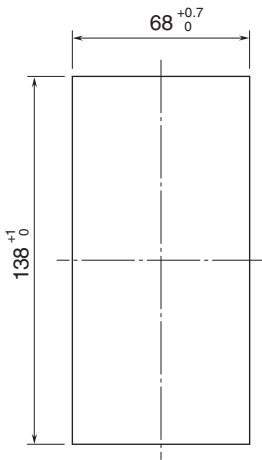

• Clustered mounting

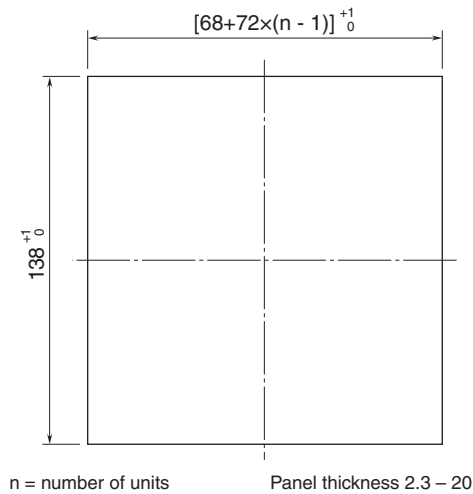

■ Caution

- IP55 is ensured for the front panel of the unit mounted independently according to a panel. Test the sealing at the mounting surface once the device is installed.
- Set the unit on a vertical surface with its operation buttons at the lower side. Mounting in other directions may cause heat built up inside the unit and shorten its life span or degrade its performance.
- Ensure that there is sufficient space for ventilation inside a panel. Do not install above the devices that generate high heat such as heaters, transformers or resistors. Leave at least 30 mm (1.2 inch) space above, below and behind the unit for maintenance purpose (e.g. wiring, removing or installing).

SCHEMATIC CIRCUITRY & CONNECTION DIAGRAM

Note: In order to improve EMC performance, bond the FG terminal to ground.

Caution: FG terminal is NOT a protective conductor terminal.

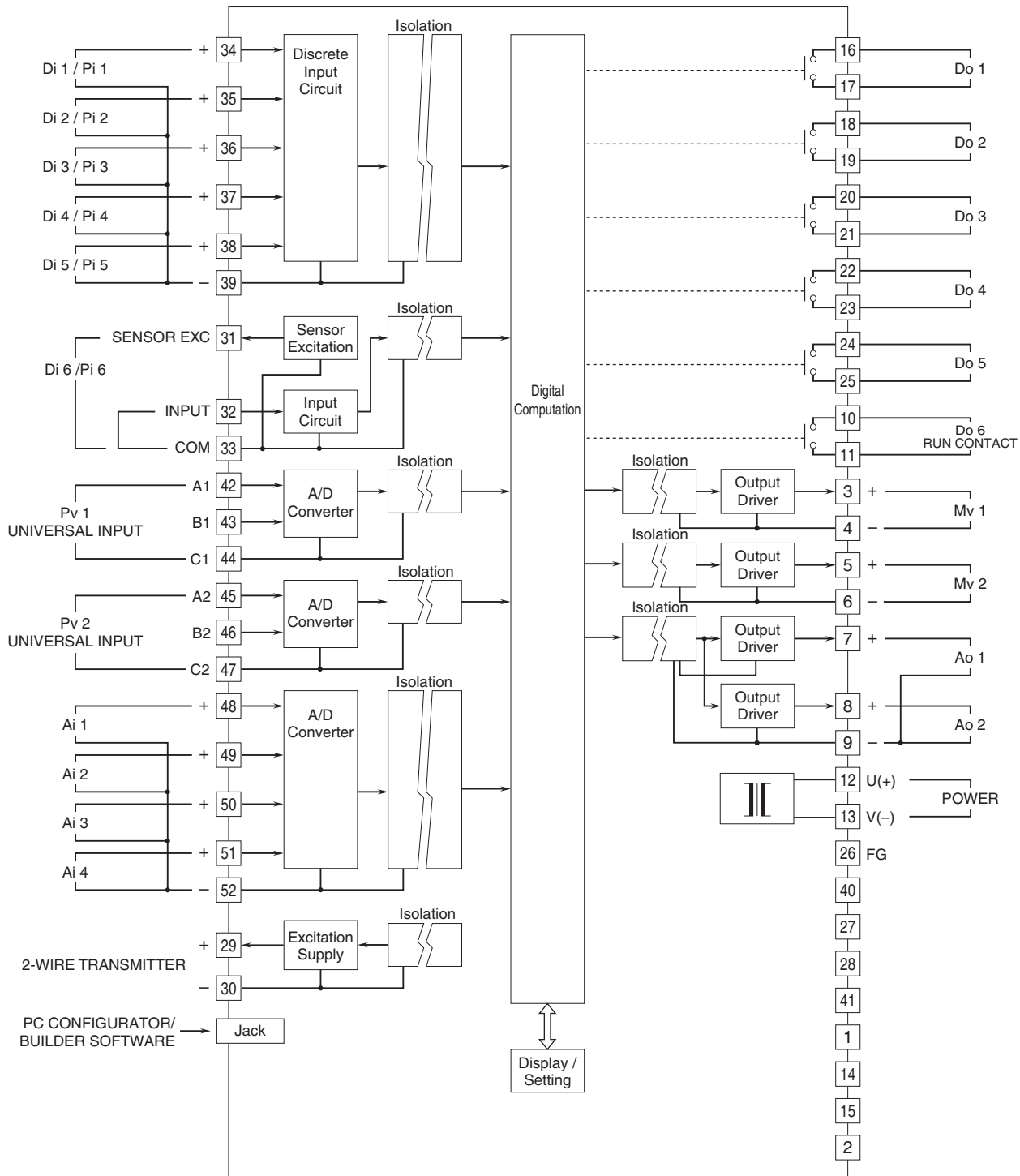

■ UNIVERSAL INPUT CONNECTION E.G.

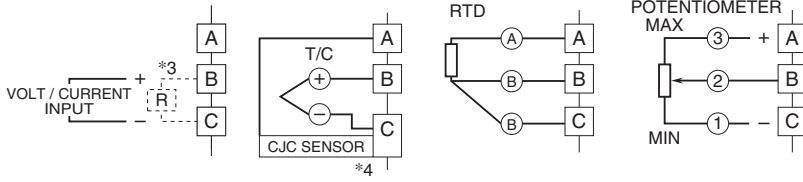

■ DISCRETE INPUT PULSE INPUT CONNECTION E.G.:

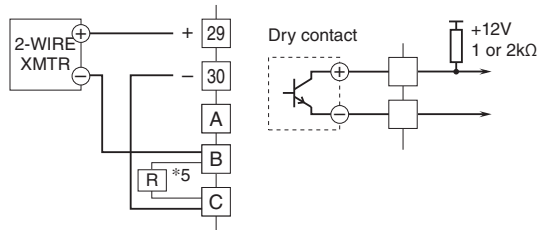

*3. Connect input resistor module (model: REM4) for current input.

*4. Connect CJC sensor for thermocouple input.

*5. Connect input resistor module (model: REM4).



Specifications are subject to change without notice.